

Service Manual



B0 Wide-Format Professional Inkjet Printer

EPSON Stylus Pro 9500



EPSON®

SEIJ00005

NOTE:

The contents of this book may change at anytime without notice.

No patent liability is assumed with respect to the use of information contained herein.

SEIKO EPSON CORPORATION assumes no liability for problems or damages resulting from the use of the information contained herein.

EPSON is a registered trademark of SEIKO EPSON CORPORATION.

Other product names used herein are for identification purposes only and may be trademarks of their respective owners. EPSON disclaims any and all rights in those marks.

Copyright 2000 SEIKO EPSON CORPORATION.

PRECAUTIONS

There are cautionary notes throughout the text to help you avoid personal injury or equipment damage.



Signals a precaution which, if ignored, could result in serious or fatal personal injury. Great caution should be exercised in performing procedures preceded by a WARNING heading.



Signals a precaution which, if ignored, could result in damage to equipment.

Always observe the measures listed below when performing repair or maintenance procedures.

WARNING

1. Always disconnect the product from both the power source and host computer before performing any maintenance or repair procedure.
2. No work should be performed on the unit by persons unfamiliar with basic safety measures dictated for all electronics technicians in their line of work.
3. In performing testing described in this manual, do not connect the unit to a power source until instructed to do so. When the power supply cable must be connected, use extreme caution in working on the power supply and other electronic components.

CAUTION

1. Repairs on EPSON products should be performed only by an EPSON-certified repair technician.
2. Make certain that the source voltage is the same as the rated voltage listed on the serial number/rating plate. If the EPSON product has a primary AC rating different from the available power source, do not connect it to the power source.
3. Always verify that the EPSON product has been disconnected from the power source before removing or replacing printed circuit boards and/or individual chips.
4. To protect sensitive microprocessors and circuitry, use static discharge equipment, such as anti-static wrist straps, when accessing internal components.
5. Replace malfunctioning components only with those components recommended by the manufacturer; introduction of second-source ICs or other nonapproved components may damage the product and void any applicable EPSON warranty.

Revision Status

Revision	Issued Date	Description
A	31 August 2000	First Established Edition

PRODUCT DESCRIPTION

Features	7
Professional Color Printing Features.....	7
Consumable Products & Options	8
SPECIFICATIONS.....	9
Interfaces.....	18
Initialization.....	23
Control Panel.....	24
Normal Mode Panel Display.....	27
Control Panel Settings.....	28
Maintenance Call.....	34
Service Errors.....	35
Service Related Printer Settings	37
Firmware Update.....	41
Jumper Settings	42

OPERATING PRINCIPLES

Component List & Illustrations.....	44
Print Mechanism Components	44
Summary of Control Circuit Operations.....	64

TROUBLESHOOTING

Outline	70
Test Points	70
General Errors.....	75

DISASSEMBLY & ASSEMBLY

Summary	83
Warnings	83
Tools.....	84
Screw List.....	84
Disassembly Flow.....	85
Removing the Housing	86
Circuit Board Removal	93
Printer Mechanism Disassembly	96
Conversion Kit	122

ADJUSTMENT

Summary	156
Caution	156
Adjustment Tools	156
Adjustment Items	158
Adjustment Steps	161
Parameter Backup	161
Firmware Update.....	164
Self-Diagnostics	166
Adjustment Menu	168
Test Menu	189
Cleaning menu	198
Parameter menu	198
Maintenance Mode.....	200
Mechanism Adjustment.....	203
Dip SW setting	218

MAINTENANCE & SETUP

General Maintenance Issues.....	220
Periodic Maintenance Items.....	221
Product Life Information	222
Important Maintenance Items During Service Operations	222
Lubrication.....	223
Unpacking and Installing	223
The Packaging	223
Contents of the Packaging	224
Unpacking and Assembling.....	225

APPENDIX

Wiring Diagrams.....	233
Connector Pin Assignments	235
C277MAIN Board	235
Parts List	239
Exploded view Diagram.....	248
Component Layout	262
Circuit Diagrams.....	264

CHAPTER

1

PRODUCT DESCRIPTION

1.1 Features

The EPSON Stylus Pro 9500 is an ultra-wide, 6-color ink jet printer with professional color output. It has the same printheads as the EPSON Stylus Color 9000. The EPSON Stylus Pro 9500 provides the following major features and more.

1.1.1 Professional Color Printing Features

- Large-size/poster printing
 - up to B0-wide paper (1118 cm/44 inches) including print-registration marks
- Excellent Photo-quality printing
 - 1440 (H) x 720 (V) dpi combined with EPSON's Microdot printing
- High-speed printing
 - 64 nozzles per color (same printhead as the EPSON Stylus Pro 9000)
 - The RISC-CPU and high-speed color raster ASIC quickly process detailed print data
 - A0/Medium Gloss Paper: Approx.17 min.(720x720dpi /Fast)
A0/Medium Gloss Paper: Approx.25 min.(720x720dpi /Beautiful)
A0/Medium Gloss Paper: Approx.50 min.(1440x720dpi /Highly detailed)
- Low running cost
 - Six separate ink cartridges so you only have to replace the empty ink cartridge (each cartridge holds 220 ml)
- Wide compatibility
 - The following interface alternatives are available:
 - IEEE-1284 bidirectional parallel interface (supports ECP mode)
 - Macintosh serial interface (approx. 1.8Mbps)
 - One Type-B expansion slot for an optional interface (x1)

- User-friendly features:
 - Two roll holders for easy switching between paper types
 - Standard roll-paper cutter
 - Auto Loading (Cut sheet)
 - Optional roll-paper take-up reel for automatically winding up your long printouts

1.1.2 Consumable Products & Options

The following table lists the consumable items and options available for use with the EPSON Stylus Pro 9500.

Table 1-1. Consumable Products & Available Options

Name	Code	Product
Doubleweight Matte Paper	S041385	24in. wide / 25m long
	S041386	36in. wide / 25m long
	S041387	44in. wide / 25m long
Glossy Paper - Photo Weight	S041388	22in. wide / 20m long
	S041389	44in. wide / 20m long
Premium Glossy Photo Paper	S041390	24in. wide / 30.5m long
	S041391	36in. wide / 30.5m long
	S041392	44in. wide / 30.5m long
Premium Semigloss Photo Paper	S041393	24in. wide / 30.5m long
	S041394	36in. wide / 30.5m long
	S041395	44in. wide / 30.5m long
Watercolor Paper - Radiant White	S041396	24in. wide / 18m long
	S041397	36in. wide / 18m long
	S041398	44in. wide / 18m long
	S041352	A3 Wide / B
	S041351	A3 Wide / B
Glossy Film	S041314	610mm wide / 20m long
	S041313	914mm wide / 20m long
	S041312	1118mm wide / 20m long
Synthetic Paper	S041399	24in. wide / 45m long
	S041400	36in. wide / 45m long
	S041401	44in. wide / 45m long
Adhesive Synthetic Paper	S041402	24in. wide / 30m long
	S041403	36in. wide / 30m long
	S041404	44in. wide / 30m long

Table 1-1. Consumable Products & Available Options (continued)

Name	Code	Product
Rip Station 5100 PS Server Series	EAI - C850092 Other - C850093	Fiery Adobe® PostScript® 3™ Server
Multi-protocol Ethernet interface card	C82362★	Type-B 10Base-T
100Mbps Multi-protocol Ethernet interface card	C82363★	Type-B 100Base-T

Note *: Two rolls can be installed at the same time.

Note **: Can only be installed in the upper spindle holder.

Note 3: These papers can be used in the Stylus Pro 9000 also.

1.2 SPECIFICATIONS

PRINT SPECIFICATIONS

Print method:	On-demand MACH (Multi-layer Actuator Head) ink jet E-MACH type
Nozzle configuration:	Black: 64 nozzles Color: 320 nozzles/64 nozzles for each color (Yellow, Magenta, Cyan, Light Magenta, and Light Cyan)
Print direction:	Bi-directional with logic seeking (high-speed return and skip only)
Print speed:	See the following table:

- <Character mode>

Character Quality: High quality

Character Pitch: 10 cpi

Printable Area: 437 columns

Print Speed: 240 cps

- <Graphic mode>

See the table below.

Table 1-2. Print Speed by Print Mode

Table 1-2.

Horizontal Resolution	Printable Area	Printable Dot Count	Print Speed
360	1112mm	15762	241 IPS/FOL
720	1112mm	31524	33.31 IPS/FOL 33.31 IPS/4pass
1440	1112mm	63048	24IPS/FOL 33.31 IPS/4pass

Control code: ESC/P Raster (commands are not open to public)

Character Specifications:

- Character Code
PC 850 (Multilingual)
PC437 (US, Standard Europe)
- Type Faces
Bitmap LQ font: EPSON Courier IO CPI

PAPER-FEED SPECIFICATIONS

Feeding method:	Friction feed
Line spacing:	1/6 or 1/720" programmable
Paper loading:	Roll paper (two 2-inch rolls can be loaded at the same time) Single sheets loaded one at a time
Paper volume:	2" core roll paper = diameter of paper wound on roll of less than 103mm (4.05") 3" core roll paper = diameter of paper wound on roll of less than 150mm (5.9") Single sheets = one sheet at a time
Feed speed:	200 ± 10 ms (when feeding at 1/6") 2.5"/second (when continuously feeding)

PAPER SPECIFICATIONS

Size, roll paper

{Minimum paper requirements}

Paper meeting the requirements described below can be used with this printer, but neither the feeding nor printout quality is guaranteed.

- Paper Size = Width 297~1118mm
 (8.27~44.02")
 Length 720mm~45m
 (28.35~1771.65")
- Roll Size = 2" or 3" core
 paper thickness = 103mm or less (4.05")
 (two 2" rolls)
 150mm or less (5.9")
 (one 3" roll)
- Paper Thickness = 0.08~0.5mm (0.003~0.019")

- *1): There should be no wrinkles, fuzz, tearing or folding, of the paper, etc.
- * 2): The exclusive option (3" roll paper spindle) should be used when using 3" core roll paper.

{Normal paper}

For paper meeting the following requirements, the feeding operation only is guaranteed.

- Paper Size = Width 297~1118mm
 (8.27~44.02")
 Length 720mm~45m
 (28.35~1771.65")
- Roll Size = 2" or 3" spindle
 paper thickness = 103mm or less (4.05")
 (two 2" rolls)
 150mm or less (5.9")
 (one 3" roll)
- Paper Thickness = 0.08~0.11mm (0.003~0.0043")
- Paper Weight = 64~90gf/m² (17~24 lb.s)
- Paper Quality = Normal paper, recycled paper
- *1: Use at normal room temperature
 (15~25°C (59~77°F)

40~60% humidity)

- *2: The printer exerts between 300~500gf to peel off the rear edge of roll paper from the core
- *3: The exclusive option (3" roll paper spindle) is necessary when using 3" core roll paper.
- *4: This product should be used in a place with a normal room temperature environment (Temperature: 15~25°C, Relative humidity: 40~60%)
- *5: The guaranteed printable area for roll paper is from the core to the point where it is cut off.

(Reference: The remaining paper length when the paper comes off the roll is approximately 400 mm for the upper holder and approximately 300 mm for the lower holder.

{Special paper}

For special paper meeting the following requirements, the feeding operation and print quality are optimized.

Table 1-3. Special Paper Specifications

Paper	Code	Paper Size	Roll Size
Doubleweight Matte Paper	S041385	24" x 25m	2" core/ paper thickness (radius) of 103mm or less
	S041386	36" x 25m	
	S041387	44" x 25m	
Glossy Paper - Photo Weight	S041388	22" x 20m	
	S041389	44" x 20m	
Premium Glossy Photo Paper	S041390	24" x 30.5m	
	S041391	36" x 30.5m	
	S041392	44" x 30.5m	
Premium Semigloss Photo Paper	S041393	24" x 30.5m	
	S041394	36" x 30.5m	
	S041395	44" x 30.5m	
Watercolor Paper - Radiant White	S041396	24" x 18m	
	S041397	36" x 18m	
	S041398	44" x 18m	
Glossy Film	S041314	610mm x 20m	
	S041313	914mm x 20m	
	S041312	1118mm x 20m	
Synthetic Paper	S041399	24" x 45m	
	S041400	36" x 45m	
	S041401	44" x 45m	
Adhesive Synthetic Paper	S041402	24" x 30m	
	S041403	36" x 30m	
	S041404	44" x 30m	

*1): There should be no wrinkles, fuzz, tearing or folding, of the paper, etc.

*2): This product should be used in a place with a normal room temperature environment (Temperature: 15~25°C, Relative humidity: 40~60%)

* 3): The guaranteed printable area for roll paper is from the core to the point where it is cut off.

(Reference: The remaining paper length when the paper comes off the roll is

Approximately 400 mm for the upper holder and Approximately 300 mm for the lower holder.

CUT SHEET PAPER SPECIFICATIONS

Loading of the following papers into this printer is possible, but for papers other than the following plain paper and exclusive paper, feed through characteristics and print quality are not guaranteed.

Table 1-4. Usable Single Sheet Paper Specifications

Size	Dimensions (W x H)	Size	Dimensions (W x H)
Super B0	1118 x 1580mm	A2	329 x 483mm
B0	1030 x 1456mm	Super A3/B	297 x 483mm
B1	728 x 1030mm	A3	297 x 420mm
B2	515 x 728mm	ANSI E	34 x 44"
B3	364 x 515mm	ANSI D	22 x 34"
Super A0	914 x 1292mm	ANSI C	17 x 22"
A0	841 x 1189mm	ANSI B	11 x 17"
A1	594 x 841mm		

Paper Thickness: 420~728mm (16.54~28.66") long
 paper = 0.08~1.5mm
 (0.003~0.059")
 728~1580mm (28.66~62.2") long
 paper = 0.08~0.5mm
 (0.003~0.019")

{Normal paper}

For paper meeting the following requirements, only the feeding operation is guaranteed.

Table 1-5. Usable Single Sheet Paper Specifications

Size	Dimensions (W x H)	Size	Dimensions (W x H)
Super B0	1118 x 1580mm	A2	329 x 483mm
B0	1030 x 1456mm	Super A3 /B	297 x 420mm
B1	728 x 1030mm	A3	22 x 36"
B2	515 x 728mm	ANSI E	20 x 24"
B3	364 x 515mm	ANSI D	18 x 22"
Super A0	914 x 1292mm	ANSI C	34 x 44"
A0	841 x 1189mm	ANSI B	22 x 34"
A1	594 x 841mm		17 x 22"
A2	420 x 594mm		11 x 17"

- Paper Thickness = 0.08~0.11mm (0.003~0.0043")
- Paper Weight = 64~90gf/m² (17~24 lb.s)
- Paper Quality: Normal, recycled paper
 *1: Load short edge first (portrait)

[Exclusive Papers]

The following genuine exclusive papers can be used.

Table 1-6. Specifications of Genuine Exclusive Papers

Paper Name	Dimensions (H x W)	MC Glossy Paper *1	MC Imaging Paper
A3	297mm x 420mm	○	-
Super A3	329mm x 483mm	○	-

*1: Guaranteed for Uni-D printing. The paper should be loaded longitudinally.

*2: There should be no wrinkles, fuzz, tearing or folding, of the paper, etc.

*3: This product should be used in a place with a normal room temperature environment (Temperature: 15~25°C, Relative humidity: 40~60%).

Printable area: See the following illustration and table for details.

Table 1-7. Printable Area

Heading	Roll Paper	Cut Sheets
PW (width)	297 ~ 1118mm (8.27 ~ 44.02")	297 ~ 1118mm (8.27 ~ 44.02")
PL (length)	720mm ~ 45m (8.27~1771.65")	420~1580mm (16.54~62.2")
LM (left margin)	3mm/15mm* (0.12~0.59")	3mm
TM (top)	3mm/15mm*	3mm
RM (right)	3mm/15mm*	3mm
BM (bottom)	3mm/15mm*	14mm

- Note 1): The printer detects the paper width when the paper is set. (The paper width is not detected when the paper width detection setting is Off.)
- Note 2): Any image that exceeds the detected paper width, or the printable area specified by the paper size setting, is not printed. (When paper detection setting is OFF, the printer may print on the platen.)
- Note 3): The size of the margin of roll paper can be changed from the panel as shown below.
 Top and Bottom: 15 mm Left and Right: 3 mm, Top, Bottom, Left and Right: 3 mm,
 Top, Bottom, Left and Right: 15 mm.

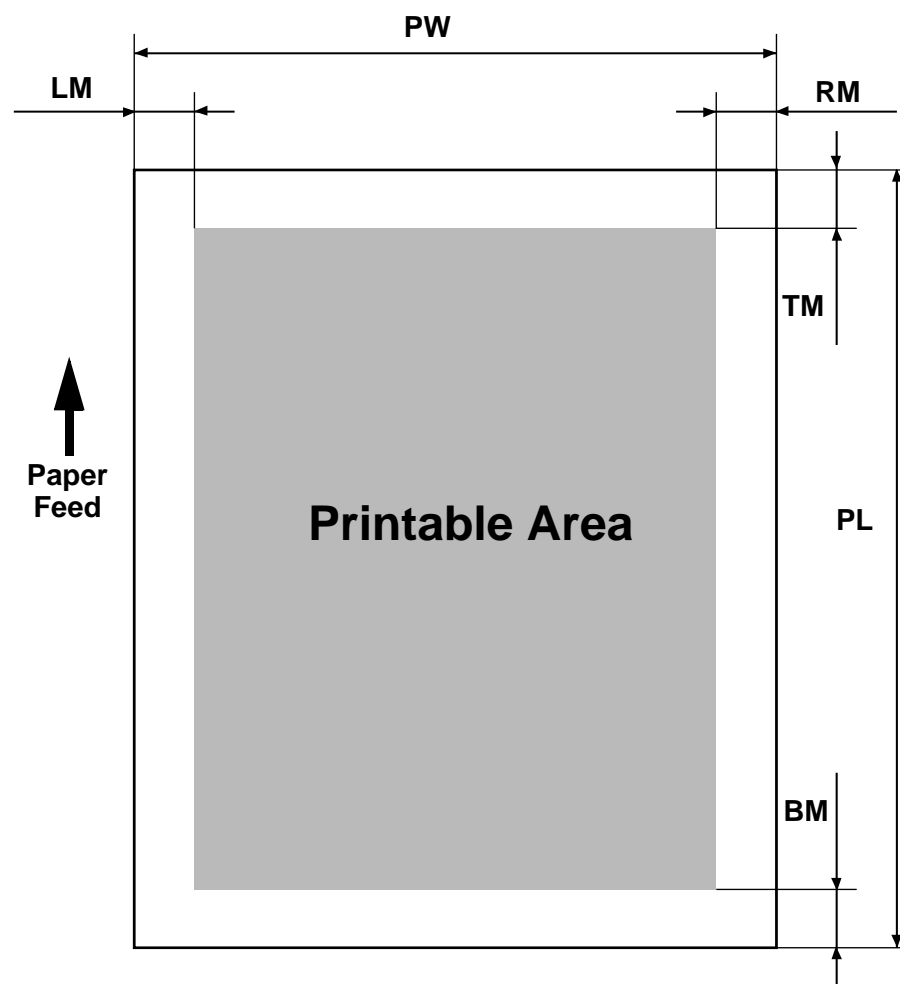

Figure 1-1. Printable Area

PAPER SET LEVER: Lever Position = Up

The paper support is released and paper setting is possible.

 Lever Position = Down

The paper is in a fixed position and is ready to print on.

During printing, it is impossible to change the position of the paper set lever.

During printing, an error occurs if the paper set lever is raised.

ELECTRICAL SPECIFICATIONS

Rated voltage range	AC100~240V
Input voltage range	AC90~264V
Rated frequency range	50 to 60Hz
Input frequency range	49 to 61Hz
Rated current	100 V System = 1.0 A 200 V System = 0.5 A
Power consumption	During operation = 100 W or less During standby = 30 W or less
Insulation resistance	10MW or higher (CD 500 V / Between AC line and chassis)
Dielectric strength	AC 1.0 Kvrms / 1 min. or AC 1.2 Kvrms / 1 sec. (between AC line and chassis)
Current leakage	0.25 mA or less

CONFORMITY/SAFETY APPROVALS

Safety Standards:

US Model	UL 1950, CSA 22.2 No. 950
European Model	EN60950 (VDE)

EMC:

US Model	FCC part 15 subpart B class B CSA C108.8 class B
European Model	EN 55022 (CISPR Pub. 22) class B EN 61000-3-2 EN 61000-3-3 EN 50082-1 IEC 801-2 IEC 801-3 IEC 801-4

Australian Model AS/NZS 3548 class B

International Energy Star Compliant
(EPA MOU2.1 Category Large Format Printer)

RELIABILITY

Service Life: [Body] 20,000 Page (A0)
 [Print Heads] 2 billion dots/nozzle
 [Cutter] Approx. 2,000 times (Super B0)

Replacement Parts Service Life:

After printing of approx. 6200 sheets (A0), the following parts are subject to simultaneous service replacement.

- Waste ink pad
- Pump assembly
- Cap assembly (New part)
- Flushing box R
- Flushing box L (New part)
- Cleaner blade



The above service replacement parts are available in the following kit.

- Name: "Maintenance Kit Stylus Pro 9500"
- Part Code: 1058462
- This maintenance kit is an exclusive kit for the Stylus Pro 9500, and should not be used for the Stylus Pro 9000.

ENVIRONMENTAL SPECIFICATIONS

Temperature/Humidity: See the following table.

Table 1-8. Temperature & Humidity

Condition	Temperature	Humidity	Notes
Operating	15~35°C (59~95°F)	30~80%	<ul style="list-style-type: none"> • Less than a month at 40°C (104°F) • Less than 120 hours at 60°C (140°F) • Without condensation
Storage	-20~40°C (-4~104°F)	20~85%	
Transportation	-20~60°C (-4~140°F)	5-85%	

Notes:

- 1) When storing the printer, make sure the printheads are in the home, capped, position.
- 2) Before transporting the printer, remove the ink cartridges and turn the ink valves screws to the closed position. Also make sure the printheads are in the home, capped, position. After transporting the printer, install new ink cartridges.
- 3) When the temperature drops below -15°C (5°F), the ink in the cartridges and printheads freezes. The ink thaws completely after three hours at 25°C (77°F).

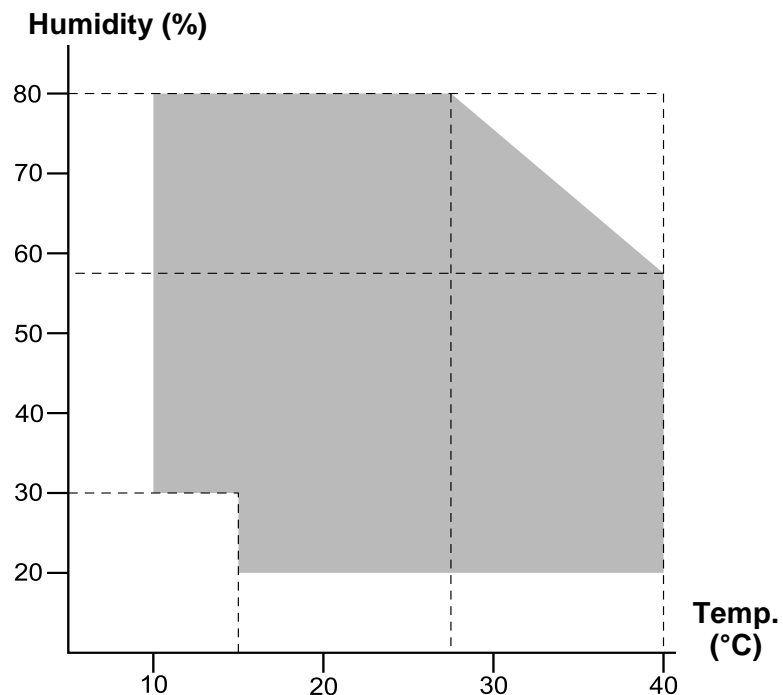

Figure 1-2. Print Temperature and Humidity

Resistance to

Vibration & Shock: See the following table.

Table 1-9. Vibration & Shock Resistance

Condition	Vibration Resistance	Shock Resistance	Notes
Operating	0.15G 10~55Hz	1G less than 1ms	X/Y/Z direction
Storage	0.50G 10~55Hz	2G less than 2ms	

INK CARTRIDGE SPECIFICATIONS

- Shape: Each ink cartridge is uniquely shaped so the cartridges cannot be inserted in the wrong slots.
- Ink colors: Black, Cyan, Magenta, Yellow, Light Cyan, Light Magenta
- Ink volume: 220 ± 5 ml
- Ink avail. for printing: 190 ± 14ml
- Print capacity: A0 = approx. 30 pages at 720dpi and 40% coverage
- Dimensions: 25.1 x 260 x 105.3mm (WxDxH)
- Weight: Approx. 370~385g (cartridge only)
- Effective period: 2 years from production (in the sealed packaging) plus time used (at room temp.)
- Storage temperature: See the table below.

Table 1-10. Ink Cartridge (Environmental) Specifications

Situation	Temperature	Notes
Transporting	-30~60°C (-22~140°F)	<ul style="list-style-type: none"> Less than 120 hours at 60°C (140°F) Less than month at 40°C (104°F)
Storage	-30~40°C (-22~104°F)	Less than a month at 40°C (104°F)
Installed	-20~40°C (-4~104°F)	Less than a month at 40°C (104°F)

CONTROLLER SPECIFICATIONS

CPU: 32 bit RISC-CPU (SH7043) 33Mhz
 ROM: [Program]
 CPU Internal = 128KB ROM
 External = 1MB (Flash ROM/4Mbit x 2)
 [Font] not-installed
 RAM: 18MB (fixed)
 (16MB: SIMM/2MB: IC18,19)



The RAM installed in the form of a SIMM module is a part of system memory and cannot be replaced (to install a larger capacity SIMM) or removed.

Interface: [Standard]
 IEEE1284 Bidirectional Parallel Interface
 Macintosh Serial Interface
 Type-B Card Slot (x1) for optional interface

PRINTER DIMENSIONS & WEIGHT

Dimensions: 1688 x 699 x 1259mm (WxDxH)
 (66.46 x 27.52 x 49.57 inches)
 Weight: 96Kg (211.91 lb.s)
 Printer alone = 74Kg (163.32 lb.s)
 Stand = 22Kg (48.59 lb.s)

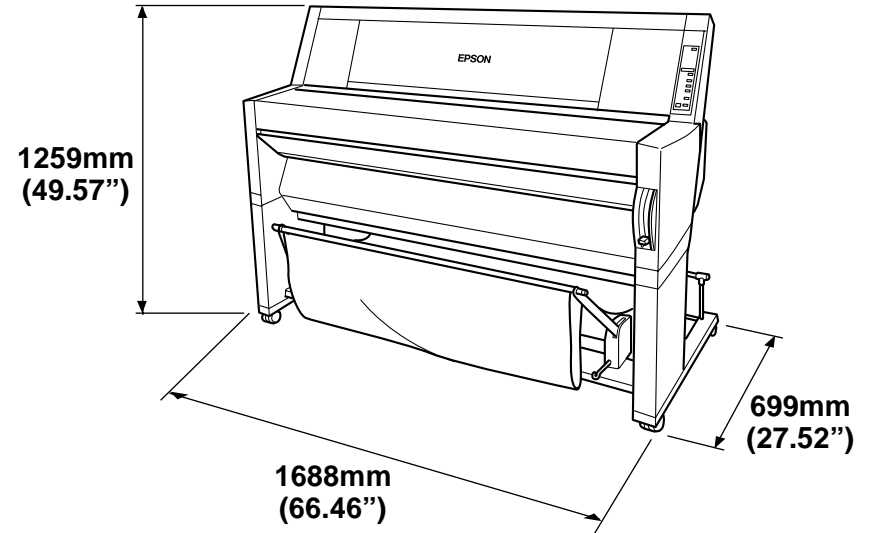

Figure 1-3. Printer Dimensions

1.2.1 Interfaces

The EPSON Stylus Pro 9500 is equipped with parallel and Macintosh serial interfaces and a card slot for an optional Type-B interface. This section provides information on each interface.

PARALLEL INTERFACE

Parallel Interface [Compatibility Mode]

Transmission mode: 8-bit parallel, IEEE-1284 compatibility mode

Synchronization: By STROBE pulse

Handshaking: By BUSY and $\overline{\text{ACKNLG}}$ signal

Logic Level: TTL compatible level (IEEE-1284 Level 1 device)

Connector: 57-30360 (Amphenol) or equivalent 36-pin. The interface cable length should be only long enough to reach the shortest necessary distance.

Table 1-11. Connector Pin Assignments - Forward Channel

Pin No.	Signal Name	Return Pin	In/Out	Functional Description
1	STROBE	19	I	Data reception pulse, 0.5uS or greater pulse width required. Usual state is HIGH, and reads data after going to LOW state.
2-9	DATA0~7	20-27	I	The DATA0 through DATA7 signals represent data bits 0 to 7, respectively. Each signal is at high level when data is logical 1 and low level when data is logical 0. These signals are used to transfer the 1284 extensibility request values to the printer.
10	ACKNLG	28	O	When LOW the printer has finished preparing to receive signals and can accept data. Pulse width is about 1uS or 3uS Printer clock signal.
11	BUSY	29	O	HIGH means the printer cannot receive data. This occurs when the printer is receiving data or when the printer is in an error state.
12	PE	28	O	HIGH means no paper is loaded. (LOW means an error.)
13	SLCT	28	O	Always HIGH. Pulled up to +5V via 1.0Kohm
14	AFXT	30	I	Not used
15	NC			Not connected
16	GND			Ground for twisted pair return
17	Chassis			Ground for frame/body
18	Logic H			Pulled up to +5V via 3.9Kohm
19-30	GND			Ground for twisted pair return
31	-INIT	30	I	Pulse width of 50uS or more means LOW pulse, and the falling edge of LOW signal causes the printer to initialize.
32	ERROR	29	O	LOW means printer error
33	GND	----	----	Ground for twisted pair return
34	NC	----	----	Not connected
35	+5V	----	O	HIGH during normal operation. Pulled up to +5V via 1.0Kohm
36	SLCTIN	30	I	Not used

Note: See the next page.

Note 1: *1 The return side means the twisted pair return and is connected to the signal ground level. Furthermore, when interfacing, a twisted pair cable should definitely be used for each signal and the return side should definitely be connected. Also, use of a shielded cable and connection to the chassis ground of the center machine and the printer, respectively are effective countermeasures against noise.

Note 2: All the interface conditions are TTL level standard conditions. The rise and fall time of each signal is 0.2_s or less.

Note 3: There must not be any data transfer with disregard of the /ACKNLG or BUSY signals. (Data transfer to this printer must be performed after the ACKNLG level is confirmed or when BUSY is in the "LOW" state.)

Note 4: A horizontal line above the signal name shows a LOW active signal.

Table 1-12. Parallel Interface Timing

Parameter	Minimum	Maximum
tsetup	500ns	--
thold	500ns	--
tstb	500ns	--
tready	0	--
tbusy	--	500ns
treply		--
tack	Typical 2us	
Tnbusy	0	--
tnext	0	--

Nibble Mode

Transmission mode: 8-bit Parallel
 Synchronization: External Supply STROBE Pulse Signal
 Handshaking: ACKNLG and BUSY Signal
 Signal level: TTL level (IEEE-1284 level 1 device)
 Connector: 57-30360 (Amphenol) or equivalent
 Data transfer timing: Refer to IEEE-1284 specification
 Data requests: When the printer receives the hexadecimal values 00H or 04H, the printer responds in the following manner:
 00H: The printer enters reverse channel mode, allowing data to be sent to the host.
 04H: The printer sends the device ID to the host; the device ID consists of the following strings

device ID:

<00H><4EH>
 MFG: EPSON
 CMD: ESCPL2, BDC
 MDL: Stylus[SP]Pro[SP]9000;
 CLS: PRINTER
 DES: EPSON[SP]Stylus[SP]Pro[SP]9500
 Note: [SP] equals space code 20H

Table 1-13. Connector Pin Assignments - Reverse Channel

Pin No.	Signal Name	Return Pin	In/Out	Functional Description
1	HostClk	19	I	Host clock signal.
2-9	Data0-7	20-27	I	Each signal is at high level when data is logical 1 and low level when data is logical 0.
10	PeriphClk	28	O	Printer side clock signal.
11	PeriphAck/ PtrBusy	29	O	Printer side BUSY signal and data bit 3/7 in the reverse channel.
12	AckData Req	28	O	Acknowledge data request signal and data bit 2/6 in the reverse channel.
13	Xflag	28	O	X-flag signal and data bit 1/5 in the reverse channel.
14	HostBusy	30	I	Host computer side BUSY signal.
15	NC			(Not used.)
16	GND			Ground for twisted pair return.
17	Chassis GND			Chassis Ground
18	Logic-H		O	+5 V pull-up at 3.9 K Ohm.
19-30	GND			Ground for twisted pair return
31	/INIT	30	I	(Not used.)
32	/DataAvail	29	O	Data Available signal and data bit 0/4 in the reverse channel.
33	GND			Ground for twisted pair return

Table 1-13. Connector Pin Assignments - Reverse Channel

Pin No.	Signal Name	Return Pin	In/Out	Functional Description
34	NC			(Note used.)
35	+5V	----	O	Normally HIGH state. +5 V pull-up at 1.0 K Ohm
36	1284-Active	30	I	1284 Active signal.

ECP Mode

Transmission mode: IEEE-1284 ECP mode

Synchronization: Refer to IEEE-1284 specification

Handshaking: Refer to IEEE-1284 specification

Signal level: TTL level IEEE-1284 level 1 device

Data transfer timing: Refer to IEEE-1284 specification

Data requests: When the printer receives the hexadecimal values 10H or 14H, the printer responds in the following manner:
 10H: The printer enters reverse channel mode, allowing data to be sent to the host.

14H: The printer sends the device ID to the host; the device ID consists of the following strings:

device ID:

<00H><4EH>

MFG: EPSON

CMD: ESCPL2, BDC

MDL: Stylus[SP]Pro[SP]9500

CLS: PRINTER

DES: EPSON[SP]Stylus[SP]Pro[SP]9500

Note: [SP] equals space code 20H

Table 1-14. Connector Pin Assignments - Reverse Channel

Pin No.	Signal Name	Return Pin	In/Out	Functional Description
1	HostClk	19	I	Host clock signal.
2-9	Data0-7	20-27	I	Each signal is at high level when data is logical 1 and low level when data is logical 0.
10	PeriphClk	28	O	Transmits data to the host computer from the printer.
11	PeriphAck/ PtrBusy	29	O	The printer uses this signal for forward direction flow control. Also, this signal offers data bit 9, which is used to judge whether information output in the reverse direction data signals is command information or data information.
12	AckData Req	28	O	The printer drives in Low and acknowledges a nReverseRequest.
13	Xflag	28	O	X-flag signal and data bit 1/5 in the reverse channel.
14	HostBusy	30	I	The host uses this signal for reverse direction flow control. Also, this signal offers data bit 9, which is used to judge whether information output in the forward direction data signals is command information or data information.
15	NC	-	-	(Not used.)
16	GND	-	-	Ground for twisted pair return.
17	Chassis GND			Chassis Ground
18	Logic-H	-	O	Normally "HIGH" level. +5 V pull-up at 3.9 K Ohm
19-30	GND	-	-	Ground for twisted pair return.
31	/INIT	30	I	(Not used.)
32	/DataAvail	29	O	This signal is used to generate host interrupts.

Table 1-14. Connector Pin Assignments - Reverse Channel

Pin No.	Signal Name	Return Pin	In/Out	Functional Description
33	GND			Ground for twisted pair return.
34	NC			(Not used.)
35	+5V	----	O	Normally HIGH state. +5 V pull-up at 1.0 K Ohm.
36	1284-Active	30	I	1284 Active signal. "HIGH" when in the ECP mode.

SERIAL INTERFACE

Transmission mode:	Based on RS-423
Synchronization:	Synchronous
Transfer speed:	About 1.8 Mbps
Data format:	Start bit: 1 bit Data bit: 8 bits Parity bit: None Stop bit: 1 bit
Handshaking:	X-ON/X-OFF, DTR protocol
Adaptable connector:	8-pin mini-DIN
Recommended I/F cable:	Apple Genuine Cable

Table 1-15. Pin Assignment

Pin No.	Signal Name	I/O	Description
1	SCLK	O	Synchronous clock signal
2	CTS	I	Clear To Send
3	TXD-	O	Transmit Data (-)
4	SG	I	(Signal Ground)
5	RXD-	I	Receive Data (-)
6	TXD+	O	Balanced Transmit Data (+)
7	DTR	O	Data Terminal Ready
8	RXD+	I	Balanced Receive Data (+)

- DTR, Xon, Xoff Handshake Timing:

Table 1-16. DTR, XON/XOFF Handshake Timing

State	Buffer Space	X-ON/X-OFF	DTR
Busy	Less than 3072 bytes	Send X-OFF code	OFF
Ready	More than 5120 bytes	Send X-ON code	ON

OPTIONAL INTERFACE

A Type B optional interface (Level 2 / 1200 mA type) can be used.

- Reply Message:

<When a Coax or Twinax Interface is installed> (Short Version)

- When using Co-ax/Twin-ax interface card:
 - Main type: MTP48p, PW127cl10cpi, PRG (KAxxxx)rev, AP1200ma
 - Product name: Stylus[SP]Pro[SP]9500
 - Emulation type: ESCPL2-00
 - Entity type: EPSONLQ2

<When an interface other than the above is installed>

- Main type: MTP48p, PW127cl10cpi, PRG (KAxxx)rev, AP1200ma, SPD0fast
- Product name: Stylus[SP]Pro[SP]9500
- Emulation type: ESCPL2-00
- Entity type: ESPONLQ2

1.2.1.1 Receiving Buffer Full Operation

When receiving data via the parallel interface or the optional Type B interface while in a state where no error has occurred (including the Pause state), if the available capacity of the buffer drops to 4 KB or less, the printer receives at 1 byte/sec. and prevents the host from issuing a time out.

At the point when the available capacity of the buffer becomes 8 KB or higher, 1 byte/sec. reception is canceled and reception stops when the available capacity is 32 bytes or less. At the point when the available capacity recovers to 1K-byte or higher, reception at 1 byte/sec. is resumed.

1.2.1.2 Interface Selection

It is possible to switch between the manual fixed selection function or auto selection function to select one of the interfaces which the printer is equipped with (parallel, serial or optional interface).

- Manual Fixed Selection:
One of the interfaces which the printer is equipped with, can be selected and fixed as the default setting.
- Auto Selection Function:
After the power is turned on, the interface from which data are first received is selected. After that, if a predetermined period of time (fixed at 10 seconds) passes during which the reception of data is stopped, the printer enters the idle state (a state where no interface is selected), then selects the interface from which it first receives data next.
- Concerning interface selection and interface state:
 - When an interface other than the parallel interface is selected, the parallel interface is set in the BUSY state. At this time, the LH signal goes "L." The meaning of LH = L is that the power is cut off. That is, it shows that the 1284 interface cannot respond. Therefore, a host computer requesting reverse transmission must first check LH. When the serial interface is not selected, DTR switches to the MARK (High) state.
 - When the optional interface is not selected, the OFF-LINE bit is set in the Main Status Register (MNSTS).
 - After the printer has been initialized, or when it is in the idle state (with no interface selected), the status of each interface is shown below.
 - Parallel Interface : READY State
 - Serial Interface : DTR = SPACE (Low) State
 - Optional Interface : OFF-LINE bit of the Main Status Register (MNSTS) is reset.
 - An interrupt signal, like the -INIT signal of the parallel interface, is disregarded while that interface is not selected and while in the Nibble mode or ECP mode.

1.2.2 Initialization

This section describes the initialization procedures for the EPSON Stylus Pro 9500. There are three ways to initialize the EPSON Stylus Pro 9500:

- Hardware initialization:
When the power is turned on or a cold-reset command is sent to the printer (remote RS command), the printer does the following:
 - Initializes the printer mechanism
 - Clears the input data buffer
 - Clears the print buffer
 - Restores the default values
- Software initialization:
When the printer receives an ESC@ command, it does the following:
 - Clears the print buffer
 - Restores the default values
- Control panel (operator) initialization:
When the Reset button is pressed or the printer receives an -INIT signal (negative pulse) from the parallel interface, the printer:
 - Paper Eject (In the case of roll paper, the printed part is skipped and when "Auto; Cut" is set in the paper select settings of the panel settings, the paper is cut, and when "Cutter Off" is set, the paper is not cut.)
 - Caps the printheads
 - Clears the input data buffer
 - Clears the print buffer
 - Resets the default values

1.2.2.1 Initial Settings

The default values are shown below.

Page Position:	Current paper position as page-start position
Line feed:	1/6"
Right margin:	440th character
Left margin:	1st character
Character pitch:	10 CPI
Print mode:	Text mode (non-raster graphics mode)

Furthermore, as for the panel settings, default settings and remote command storable items, their contents in memory are set at the default values.

1.3 Control Panel

This section describes the control panel, the buttons, the lights, and the way you make settings.]

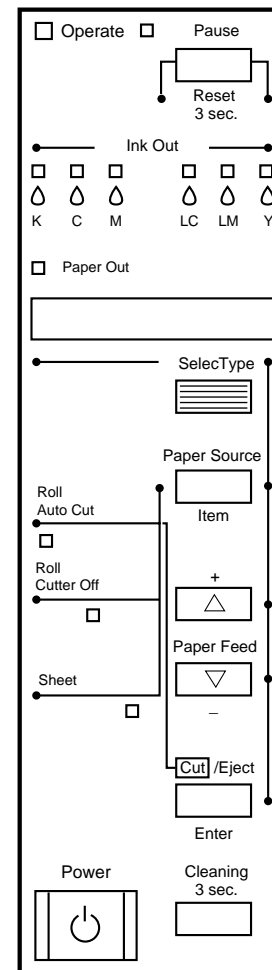

Figure 1-4. Control Panel

OPERATION BUTTONS

The functions of each of the buttons on the operation panel are as shown in the following table.

Table 1-17. Control Panel Buttons & Functions

Button (Second function)	Function (Normal)	SelectType Function	Power-On Function
Power	Power on/off	N/A	N/A
Pause (Reset)	<ul style="list-style-type: none"> Switch - online/off-line Reset (press for three seconds) 	N/A	Maintenance mode
SelectType	Enters SelectType mode (when printer is in Standby mode)	Selects menu or major category	N/A
Cut/Eject (Enter)	Selects *1 <ul style="list-style-type: none"> Auto Cut Cutter Off Sheet 	Confirm and save value	
Paper Feed ↑	Feeds paper backward *2	Cycles backward/ increases value	
Paper Feed ↓ (-)	Feeds paper forward *3	Cycles forward/ decrease value	
Paper Source (Item)	Selects paper source	Selects item or minor category	
Cleaning	Cleans both heads if pressed for three seconds	N/A	
Paper Source Cut/Eject Paper Feed ↓	N/A		Maintenance Mode 2
Paper Source Cut/Eject Cleaning	N/A		Firmware Update Mode
Paper Feed ↓ Cut / Eject Cleaning	N/A		Self-diagnostic Mode

Notes:

- 1: During the ink drying time, ink drying is interrupted and the specified operation is performed.
- 2: For 2 seconds after the button is pressed, the paper is fed at 12.7 mm/sec. (5.0 cps). If the button is pressed for 2 seconds longer, the paper is fed at 76.2 mm/sec. (50.0 cps). However, the paper can be reversed up to a maximum of 200 mm when the button is pressed once.
- 3: For 2 seconds after the button is pressed, the paper is fed at 12.7 mm/sec. (5.0 cps). If the button is pressed for 2 seconds longer, the paper is fed at 76.2 mm/sec. (50.0 cps).

LED INDICATORS

Table 1-18. LED Indicators

LED	Status	Condition
Operate (Green)	<ul style="list-style-type: none"> On Flashing 	<ul style="list-style-type: none"> Power on Fatal error during data processing or during power off processing.
Paper Out (Red)	<ul style="list-style-type: none"> On Flashing 	<ul style="list-style-type: none"> Shows the no paper, roll paper end, roll paper/cut sheet paper setting difference, paper support lever released or cleaning impossible error state. Shows a paper jam, paper cutting error, paper skew error, paper recognition error, cut sheet paper eject failure, or fatal error state.
Pause (Green)	<ul style="list-style-type: none"> On Flashing 	<ul style="list-style-type: none"> Print ready state. Blinks during head cleaning, during ink drying time, and during initial filling processing.
Ink Out K (Red)	<ul style="list-style-type: none"> On Flashing 	<ul style="list-style-type: none"> Ink end error state (K), I/C wrong insertion. Ink low state (K)
Ink Out C (Red)	<ul style="list-style-type: none"> On Flashing 	<ul style="list-style-type: none"> Ink end error state (C), I/C wrong insertion. Ink low state (C)
Ink Out M (Red)	<ul style="list-style-type: none"> On Flashing 	<ul style="list-style-type: none"> Ink end error state (M), I/C wrong insertion. Ink low state (M)
Ink Out Y (Red)	<ul style="list-style-type: none"> On Flashing 	<ul style="list-style-type: none"> Ink end error state (Y), I/C wrong insertion. Ink low state (Y)
Ink Out LC (Red)	<ul style="list-style-type: none"> On Flashing 	<ul style="list-style-type: none"> Ink end error state (LC), I/C wrong insertion. Ink low state (LC)

Table 1-18. LED Indicators

LED	Status	Condition
Ink Out LM (Red)	<ul style="list-style-type: none"> • On • Flashing 	<ul style="list-style-type: none"> • Ink end error state (LM), I/C wrong insertion. • Ink low state (LM)
Paper Source (Auto Cut)	<ul style="list-style-type: none"> • On • Flashing 	<ul style="list-style-type: none"> • Roll paper auto cutting is selected (The paper is cut automatically each page.) • Difference from the roll paper auto cutting setting. It shows that cut sheet paper is set.
Paper Type (Cut Off)	<ul style="list-style-type: none"> • On • Flashing 	<ul style="list-style-type: none"> • Roll paper with the cutter off is selected. • Difference between the roll paper and cut sheet paper setting. It shows that cut sheet paper is set.
Paper Type (Single Sheet)	<ul style="list-style-type: none"> • On • Flashing 	<ul style="list-style-type: none"> • Shows that cut sheet paper is selected. • Difference between the roll paper and cut sheet paper setting. It shows that roll paper is set.

1.3.1 Normal Mode Panel Display

Messages are displayed in the LCD in the operation panel corresponding to the printer status and error occurrence and other conditions. The messages displayed are shown in the following table. Furthermore, the messages in the following table are listed in the order of their display processing priority, from high priority to low.

Table 1-19. LCD Messages

Display Message	Meaning
SERVICE REQ nnnnnnnn *2	Fatal error
MAINTENANCE REQ nnnn *3	Printer requires maintenance from qualified service person (such as replace waste ink tank)
WAIT *1	Resetting Timer IC Clearing NVRAM Performing reset operation Performing ink sequence operation Initializing the printer Dealing with initial paper operation
POWER OFF	Preparing to shut down.
INK OUT	Replacing ink cartridge.
COVER OPEN	The cover is open.
OPTION I/F ERROR	A Type-B interface error has occurred.
LOWER PAPER SET LVR	Paper Release lever is in the release position.
LOAD xxx PAPER	Wrong paper loaded.
PAPER JAM	Paper is caught inside the printer.
PAPER NOT CUT	Printer did not cut the paper (when Auto Cut selected)
PAPER NOT STRAIGHT	Paper was fed at an angle, and the printer stopped to prevent printing the page offcentered.
PAPER OUT	End of roll or sheet (or the paper detect sensor may have dust or grime blocking its operation)
RELOAD PAPER	Paper check error
INK COMPART.OPEN	Replacing ink cartridge
INK OUT	An ink cartridge is empty
PRESS PAUSE BUTTON	Waiting for paper initialize start trigger

Table 1-19. LCD Messages (continued)

Display Message	Meaning
PAUSE	Pause state.
INK DRY xx MIN	Printer waits xx minutes before the next print job to allow ink on previous print job time to dry.
INK LOW	Prepare a replacement cartridge for the color ink indicated.
PRINTING *1	Processing print data.
READ *1	Can receive and print data.
RESET	In the process of re-initializing.
TURN PWR OFF AND ON	Turn the printer off and turn it on again.

Notes:

- 1: If "Widen" is selected in the "Platen Gap" item in the panel settings, the letter "H" is displayed in the 20th column.
- 2: See the separate table, Table 1-30, on page 38.
- 3: See the separate table, Table 1-29, on page 38.

1.3.2 Control Panel Settings

PANEL SETTING MENU SELECTION

By pressing the “SelectType” button while the printer is not printing, the printer switches to the panel setting mode and the printing state is automatically disabled. The following menu items are listed in the Panel Setting Mode, and the setting menu is switched in order and displayed in the LCD each time the “SelectType” button is pressed once. When selecting a menu, press the “Paper Source” button once.

To return to the print ready state, press the “SelectType” button until the “Print Ready” message is displayed in the LCD panel, or press the “Pause” button.

- Menu Selection: “SelectType” Button
- Selecting a Menu Item: “Paper Source” Button
- Mode End: “Pause” Button.

Table 1-20. Control Panel Settings

Menu Item	Panel Display
SelecType Menu	PRINTER SETTING MENU
Test Print Menu	TEST PRINT MENU
Printer Status Menu	PRINTER STATUS MENU
Paper Settings Menu	PAPER CONFIG.MENU
Cutter Replacement Menu	CUTTER REPLACE MENU
Head Alignment Menu	HEAD ALIGNMENT MENU

Selecting a menu provides you with detailed options.

PRINTER SETTING MENU

Table 1-21. Selectype Menu

Display Message	Item	Notes
PLATEN GAP	<u>AUTO</u> WIDE	Adjusts the PG width. (Normally used in Auto.) For details concerning the PG setting value, see the Operation Theory section.
PAGE LINE	<u>ON</u> OFF	When Auto Cut Off is selected on the control panel, this setting determines whether a line for manual cutting is printed.
INTERFACE	<u>AUTO</u> PARALLEL MAC OPTION	Determines which interface the printer checks for data. Auto continuously checks all interfaces and is good for normal use.
PARA I/F	<u>COMFAT</u> ECP	Determines the data transfer rate when using this interface. (Normally, leave set to Compatibility.)
CODE PAGE	<u>PC437</u> PC850	Character code setting. (PC437: expanded graphics/PC850: multi-lingual)
ROLL MARG	<u>T/B 15mm</u> 15mm 3mm	Sets the margin for roll paper. (disabled for cut sheet paper) Vertical 15 mm: A margin of 15 mm is provided on the left and right of the printed portion, and a margin of 3 mm is provided at the top and bottom / 3 mm: A margin of 3 mm is provided at the top, bottom, left and right. / 15 mm: A margin of 15 mm is provided at the top, bottom, left and right.
INIT.PANEL	EXEC.	Initialize control panel setup values
PAPER ALIGN CHK (Note 3)	<u>ON</u> OFF	Turns the paper feed skew detection setting ON / OFF. For details, see the Operation Theory section.
PAPER WIDTH DETECTION	<u>ON</u> OFF	Turns the paper feed paper width detection ON / Off. For details, see the Operation Theory section.

Notes:

- 1) The setting values in the above table with underlines are default setting values.
- 2) In the "Roll Paper Margins" setting, if "Vertical 15 mm" (15 mm is set at the top and bottom, and 3 mm is set at the left and right), or "15 mm" (15 mm is set at the top, bottom, left and right), the printing position of vertical lines and horizontal lines in the portion where 15 mm is set at a position 12 mm wider than the logical paper (the minimum margin is an area of 3 mm from the paper edge). (Therefore, the margin becomes 3 mm + 12 mm = 15 mm.) Also, if the printable area becomes X = 15 mm or greater from the right edge of the paper, that portion is not printed on.
- 3) If the "Paper Skew Error Sensing" setting is turned OFF, even if the paper is skewed as it is being fed, printing will continue, and even if the printed image spills over the edge of the paper due to skewing, the printer will not give notice of the error, so the user should take full responsibility for the possible consequences of this setting.
- 4) If the "Paper Width Sensor" setting is turned OFF, even if the paper is sensed to be in an abnormal state, printing can be continued, but in that case, the paper width is decided and printing continued based on the following standards.
 - The paper's left edge position is made the guide mark position on the paper guide.
 - The printable area is the printable area specified in the command.
 If the "Paper Width Sensor" setting is turned OFF, if printing is being done on a paper which has a particularly low reflection rate and cannot be detected by the photosensor, this setting is used. Through the "Paper Width Sensor" OFF setting, if an image which is larger than the set paper is printed, printing may be done on the platen, so the user must take the responsibility for the possible consequences. However, if detection of the top edge of the paper fails, it results in an error.

TEST PRINT MENU

Test Print Menu

In the test print menu, the test printing shown in the following table can be done. Each test is set by operating the following panel buttons. When each test printing operation is completed, the printer returns automatically to the print ready state.

- Test print menu selection: See the panel setting menu procedure.
- Test Print item selection: "Paper Source" Button
- Set print execution: "Enter" Button

In nozzle check pattern printing, the following data are printed. The printing size is approximately 9 cm (W) x approximately 3 cm (H).

- Nozzle Check Pattern
- Firmware Version (V0xxxx)
- Waste Ink Counter (xx%) (Waste ink counter remaining capacity %)



Figure 1-5. Nozzle Check Pattern Printing Results

In status sheet printing, the following data are printed. The printing size is approximately 10 cm (W) x approximately 13 cm (H).

- Printer ID (= Head ID xx - xx - xx - xx - xx - xx)
In xx, the parameters stored in NVRAM are printed out in decimal numbers.
- The order, from the left to right, is K - C - M - Y - Lc - Lm.
- Type B Interface Connection Condition
- The following printer settings
Head Gap, Border Line (perforation line), Interface (receiving settings), Parallel Interface (Receiving Speed), Code Page, Version (Firmware

version), Each Ink Life, Cutter Life, Page Count (total printed sheets count), Ink Pad (Waste Ink Life), CR Motor (CR Motor Life), PF Motor (PF Motor Life), Head (Head Life), Cleaner (Cleaning Unit Life).

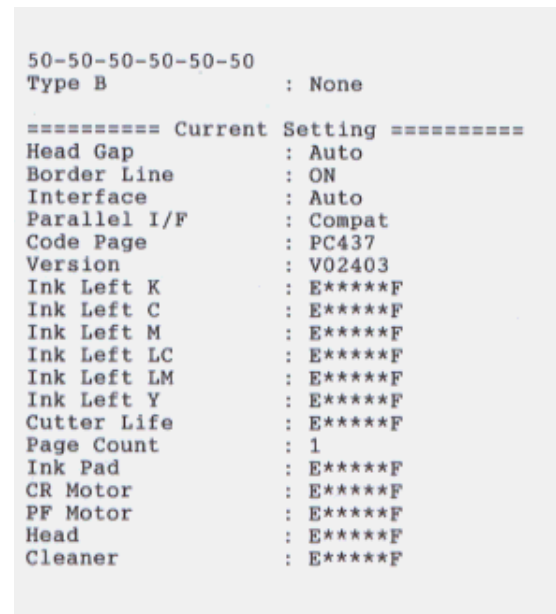

Figure 1-6. Status printing result

Table 1-22. Printer Status Menu

Display message	Meaning
VERSION	Shows the firmware version.
INK LEFT-C	Shows the amount of remaining ink - Cyan
INK LEFT-M	Shows the amount of remaining ink - Magenta
INK LEFT-LC	Shows the amount of remaining ink - Light Cyan
INK LEFT-LM	Shows the amount of remaining ink - Light Magenta
INK LEFT-Y	Shows the amount of remaining ink - Yellow
INK LEFT-K	Shows the amount of remaining ink - Black

Table 1-22. Printer Status Menu (continued)

Display message	Meaning
CUTTER LIFE	Shows the remaining useful life of the cutter
TOTAL PRINTS	Shows the total number of printed documents
WASTE INK	Displays the CR motor life.
CR MOTOR	Displays the PF motor life.
PF MOTOR	Displays the head unit life.
HEAD UNIT	Displays the head unit life.
CLEANING UNIT	Displays the maintenance kit life.

See the following table concerning the display format for each item.

- Version
This is always displayed in 6 digits. Example: V00705
- Ink Life

Table 1-23. Remaining Ink Level Display

Remaining Ink	Panel Display	Ink Remaining
E*****F	Off	100 ~ 81% remaining
E****F	Off	80 ~ 61% remaining
E***F	Off	60 ~ 41% remaining
E**F	Off	40 ~ 20% remaining
E*F	Off	20% ~ Up to just before near end
nn%	Blinking	Near end up to just before ink end
0%	Lights up	Ink End

Note 1) When this counter becomes 0%, the LED lights up and the "Ink End" message is displayed in the LCD.

Note 2) The ink consumption counter is reset when the ink cartridge is replaced.

- Printed Page Count
The total number of sheets printed is displayed by a decimal number with a maximum of 6 digits.
- Cutter Life and Other (Motors, ink pad, heads, cleaning unit)

Table 1-24. Cutter Life & Other Displays

Remaining Ink	Life
E*****F	100 ~ 81% remaining
E****F	80 ~ 61% remaining
E***F	60 ~ 41% remaining
E**F	40 ~ 20% remaining
E*F	20% ~ 1% remaining
E	Less than 1% remaining

Note 1) When the remainder on the cutter life counter becomes 0%, it does not result in a fatal error since this is only a guideline. The cutter life counter is initialized by the "Cutter Replacement Operation."

Note 2) When the waste ink counter becomes less than 1%, a maintenance error occurs. If it reaches 0%, a Service Call error occurs. The counter is reset in "Maintenance Mode 2" when the waste ink pad replacement operation is performed.

Note 3) When remainder on the CR motor life counter becomes 0%, a fatal error is displayed. Concerning the PF motor, head units and cleaning unit, there is no error display. The CR motor life counter is reset in "Maintenance Mode 2."

CUTTER REPLACEMENT MENU

The following table includes the steps/messages that must be followed to replace the cutter.

Each type of setting can be accomplished by operating the following panel buttons.

- Cutter Replacement Menu Selection: See the panel setting menu procedure.
- Cutter Replacement: "Paper Source" button
- Changing Setting Values: "+" or "-" button
- Setting the Set Values: "Enter" button
- Mode End: "Pause" button

Table 1-25. Cutter Replacement Messages

Display Message	Item	Notes
CUT.REPLACE	EXEC.	Prepare a replacement cutter and
OPEN LOWER COVER	-	Open the front cover.
REPLACE CUTTER	-	Remove the old cutter and install a new one.
CLOSE LOWER COVER	-	Close the front cover. The printer is ready.

In this mode, if cutter replacement is carried out, the "Cutter Life" counter in the print status menu is reset.

GAP ADJUSTMENT MENU (BI-D ADJUSTMENT MENU)

The paper thickness setting, Bi-D, gap (adjustment of the Bi-d deviation between the left and right heads), and printing of the adjustment pattern as well as adjustment are executed in the gap adjustment menu.

Each setting is made by operating the following panel buttons. If you select the Gap Adjustment Menu, you cannot proceed to selection of the other items without performing the "Paper Thickness" setting. After setting the paper thickness (using the Set button), the menu automatically changes to the adjustment mode.

- | | |
|---|---------------------------------------|
| <input type="checkbox"/> Gap Adjustment Menu Selection | See the panel setting menu procedure. |
| <input type="checkbox"/> Item Selection | "Paper Source" button |
| <input type="checkbox"/> Changing or Selecting Setting Values | "+" or "-" button. |
| <input type="checkbox"/> Setting the Set Value | "Enter" button |
| <input type="checkbox"/> Mode End | "Pause" button |

Table 1-26. Gap Adjustment Menu

Display	Setting Value	Contents
PAPER THICK	Standard or 0.0 ~ 1.6 mm	Specify the paper thickness used in the gap adjustment in 0.1 mm units. Ordinarily, the printer is used with the "Standard" specification, and in this case, the paper thickness becomes as follows: Paper Thickness Detection Sensor detection results = If [ON / Thin Paper] : 0.2 mm If [OFF / Thick Paper] : 1.2 mm
ADJUST. PATT.	Print All #1-#6	Specifies the gap adjustment pattern to be printed. (All patterns or the desired pattern.)
#1	1-7-15	Bi-D Adjustment (240 cps, Normal dot, Left)
#2	1-7-15	Bi-D Adjustment (240 cps, Normal dot, Right)
#3	1-7-15	Bi-D Adjustment (240 cps, Normal dot, Left)
#4	1-7-15	Bi-D Adjustment (240 cps, Normal dot, Right)
#5	1-7-15	Gap Adjustment 1 (240 cps, Normal dot)
#6	1-7-15	Gap Adjustment 3 (333 cps, Normal dot)

Note 1) Values with underlines show default values.

□ Setting Method

- 1) Set paper.
- 2) Enter the Gap Adjustment Menu by the panel.
- 3) If the paper thickness is set on 0.2 mm or 1.2 mm by the panel, it is recognized as being the same as "Standard." If you are setting other values, input the paper thickness for the paper you are using in 0.1 mm units, in accordance with the paper's specifications. The purpose for inputting the paper thickness at the first is to enable the printing of a pattern right from the first that is thought to be close to the correction value that is already being maintained by the printer, and thus to reduce the number of times the operation has to be repeated.
- 4) Select an adjustment pattern to print (either all or individually) and print it. After printing, the adjustment value input menu for that pattern will be displayed in the LCD.
- 5) Input the pattern No. for the printed pattern that has the smallest deviation in each adjustment item displayed in the LCD.
- 6) Repeat steps 4) ~ 5) until adjustment of all the items has been completed.

Note 1) If you are carrying out gap adjustment printing, printing paper with the following lengths is necessary.

- When selecting and printing 1 pattern: Approx. 7 cm.
- When selecting and printing all printing patterns (6 patterns): Approx. 40 cm.

Note 2) Always, in printing of each pattern, 1 block of 15 patterns is printed 6 times. Pattern No. 8 of the 15 patterns in one block shows the current setting value.

1.3.3 Maintenance Call

Some of the mechanical units used in this printer have counters which count down the remaining service life based on the proper service life for each unit, and when the predetermined value is reached, a "Maintenance Call nnnn" message is displayed. If this message is displayed, it indicates that the end of the service life of the affected unit is nearing, so it is necessary to replace the affected unit as soon as possible.

If this message is displayed, the "Print?" or "Printing" display message is replaced with the "Maintenance Call nnnn" message, and after replacing the affected part, it is not cleared but continues to be displayed until the counter is cleared in "Maintenance Mode 2."

In the Stylus Pro 9500, when the remaining capacity of the waste ink pad is less than 1% only, the following maintenance call is displayed in the LCD.

Even if the maintenance call is displayed, it is treated as a warning and it is possible to continue printing.

Table 1-27. Maintenance Call / Code List

Error Code	Error Content
0100	• Waste ink pad service life (less than 1% of capacity remaining)

If use of the printer is continued while this maintenance call message is being displayed, the remaining capacity of the waste ink pad will reach 0%, then a Service Call error, 00000100, will be displayed.

1.3.4 Service Errors

When “Service Req nnnnnnn” appears on the LCD display, a fatal error requiring a service technician has occurred. The nnnnnnn indicates what needs to be fixed to return the printer to a working state.

Table 1-28. Maintenance Call / Error Code List

Error Code	Error Content
00000100	Waste ink pad service life Note 1) (Replacement of the specified part and clearing of the counter are necessary.)
00000101	Ink supply tube wear Note 2)(This is equivalent to using the printer beyond the product’s service life, so an error is displayed in consideration of damage due to ink supply tube wear. Therefore, when this error occurs, the status of the ink supply tubes should be checked.)
00010000	PF Motor/ encoder check error.
00010001	PF Motor / Motor out of synch.
00010002	PF Motor / Overcurrent
00010003	PF Motor / In Position Time Out
00010004	CR Motor / Encoder check error
00010005	CR Motor / Motor out of synch.
00010006	CR Motor / Overcurrent
00010007	CR Motor / In Position Time Out
00010008	Servo interrupt WDT time out error
00010009	System interrupt WDT time out error
0001000A	CR home position sensor failure
0001000B	PF home position sensor failure
0001000C	Head slide (SLID) home position sensor failure
0001000E	Cover sensor failure (01)
0001000F	CR Motor / PWM output abnormal
000100010	PF Motor / PWM output abnormal

Table 1-28. Maintenance Call / Error Code List

Error Code	Error Content
00020000	NVRAM error
00020001	NVRAM SUM Error
00020002	00020002
00020003	SRAM Check Error
00020004	DRAM Check Error
00020005	Vector Registration Error
00020006	CGRAM Error
00020007	Operation Code Error
00020008	DMA Error
00020009	Flash Memory SUM Error
0002000A	CPU ROM Error
0002000B	Insufficient Internal Memory Error
0002000C	Review Error
10000004	CPU Vector 4 / General improper command issued.
10000006	CPU Vector 6 / Slot improper command
10000009	CPU Vector 9 / CPU address error
1000000A	CPU Vector 10 / DMAC / DTC address error
1000000B	CPU Vector 11 / WDT time out error

Note 1) The following parts should be replaced and the relevant service life counter cleared in “Maintenance Mode 2.”
 [Replacement Parts]: “Maintenance Kit Stylus Pro 9500 (Part Code 1058463)”
 Counter Clear: (Clear the counters in “Maintenance Mode 2” (Next page).)

“Waste Ink” Initialization
 “Cleaning” Initialization

Note 2) When this error occurs, check the condition of the ink supply tubes. Even if there is no problem, it should be recommended to the user that the parts comprising the CR System periodic replacement parts kit, which is scheduled for introduction be replaced. If the printer is to be used until CR system periodic replacement parts kit parts are replaced, carry out "CR Motor Initialization" in "Maintenance Mode 2" and cancel the error.

1.3.5 Service Related Printer Settings

When the printer is not functioning properly, there are three modes that help you detect what is wrong and can help you fix the problem. These modes are "Maintenance Mode", "Maintenance Mode 2", and "Self-Diagnostic Mode". To enter a mode, press and hold down the appropriate button (described below) while turning on the printer.



The following explanations regarding control panel service functions and for service and support purposes only, none of this information is to be shared with the end user.

MAINTENANCE MODE

- Start Button: Turn the Power switch On while pressing the "Pause" button.
- Setting Item Selection: "Paper Source" Button
- Changing Setting Values: "Setting Value +" or "Setting Value -" Button
- Setting the Set Values: "Enter" Button
- Setting End: Power ON/OFF
- Power-on button: Pause

Message	Item	Explanation
HEX DUMP	PRINT	This prints out print data transferred to the printer in hexadecimal form. 16 data items per line are displayed and in addition, an ASCII character corresponding to those data is printed on the right side. If there are no characters, such as print or control codes, which correspond to the data, a "." (period) is printed. The panel settings cannot be set while the printer is in this mode. To end this function, first stop printing by operating the Pause button, then turn the power switch off.
LANGUAGE	ENGLISH FRENCH ITALIAN GERMAN SPANISH PORTUGUE	The language displayed in the LCD screen can be select English, French, Italian, German, Spanish, Portuguese.
MW7	A B	This selects M/W operation in the 720 x 720 dpi mode. A is the operating mode that reduces banding in Bi-D printing. B is the Stylus Pro 9000 / 7000 720 dpi x 720 dpi interchangeable operating mode.

Note 1): Settings with underlines in the table show default values.

Note 2): During HEX dump execution, the message “HEX MODE” is displayed.

Note 3): If you are using the Stylus Pro 7000 to print in the single color mode at 720 x 720 dpi, if banding is prominent, selecting this mode may possibly reduce banding.

MAINTENANCE MODE 2

- Start Button: Turn the Power switch On while pressing the following panel buttons to start.
 - “Paper Source Button” + “Cut / Eject Button” + “Paper Feed – Button”
- Setting Item Selection: “Paper Source” Button
- Changing Setting Values: “Setting Value +” or “Setting Value –” Button
- Setting the Set Values: “Enter” Button
- Setting End: Power ON/OFF

This mode can be roughly divided into the following 3 items.

Table 1-29. Maintenance Mode 2 Setting Items

Item	Panel Display
Counter Display Menu	VIEW COUNTERS MENU
Counter Initialization Menu	CLEAR COUNTERS MENU
Adjustment, Setting Menu	SERVICE CONFIG MENU

For each major item, see the following page.

- Counter Display Menu

The items displayed in the Maintenance Mode 2 “Counter Display Menu” are shown below.

Table 1-30. Counter Display Menu

Item	Panel Display	Setting Value
Remaining Ink (K) counter Value Display	INK K	0~4294967295 (Decimal number)
Remaining Ink (C) counter Value Display	INK C	0~4294967295 (Decimal number)
Remaining Ink (M) counter Value Display	INK M	0~4294967295 (Decimal number)
Remaining Ink (LC) counter Value Display	INK LC	0~4294967295 (Decimal number)

Table 1-30. Counter Display Menu

Item	Panel Display	Setting Value
Remaining Ink (LM) counter Value Display	INK LM	0~4294967295 (Decimal number)
Remaining Ink (Y) counter Value Display	INK Y	0~4294967295 (Decimal number)
Cutter Life Counter Value Display	CUTTER	0~4294967295 (Decimal number)
Total Printed Sheet Counter Value Display	TTL PAGES	0~4294967295 (Decimal number)
Waste Ink Counter A Value Display	WAST INKA	0~4294967295 (Decimal number)
Waste Ink Counter B Value Display	WAST INK B	0~4294967295 (Decimal number)
CR Motor Service Life Counter Value Display	CR MOTOR	0~4294967295 (Decimal number)
PF Motor Service Life Counter Value Display	PF MOTOR	0~4294967295 (Decimal number)
Head Unit (K) Service Life Counter Value Display	HEAD K	0~4294967295 (Decimal number)
Head Unit (C) Service Life Counter Value Display	HEAD C	0~4294967295 (Decimal number)
Head Unit (M) Service Life Counter Value Display	HEAD M	0~4294967295 (Decimal number)
Head Unit (LC) Service Life Counter Value Display	HEAD LC	0~4294967295 (Decimal number)
Head Unit (LM) Service Life Counter Value Display	HEAD LM	0~4294967295 (Decimal number)
Head Unit (Y) Service Life Counter Value Display	HEAD Y	0~4294967295 (Decimal number)
Cleaning Unit Life Counter	CLEANER	0~4294967295 (Decimal number)

 Counter Initialization Menu

The items that can be initialized in the “Counter Initialization Menu” in Maintenance Mode 2 are shown below.

Table 1-31. Counter Initialization Menu

Item	Panel Display	Setting Value
Initializes NVRAM / Ink System / Mechanism Counters.	INIT.ALL	EXEC.
Initializes NVRAM contents (Panel setting information, Bi-D and Cap Adjustment parameters).	INIT.NVRAM	EXEC.
Timer Setting Value Initialization	INIT.TIMER	EXEC.
CR Motor Service Life Counter Initialization	INIT.CR MTR	EXEC.
PF Motor Service Life Counter Initialization	INIT.PF MTR	EXEC.
Head Unit Service Life Counter Initialization	INIT.HEAD	EXEC.
Cleaning Unit Service Life Counter Initialization	INIT.CLEANER	EXEC.
Total Printed Page Count Counter Initialization	INIT.TTL PR	EXEC.
Ink Level Counter Initialization	INIT.INK	EXEC.
Waste Ink Capacity Counter Initialization	INIT.WA INK	EXEC.

Adjustment Menu

The items that can be initialized in the Counter Initialization Menu in Maintenance Mode 2 are shown below.

Table 1-35 List of Adjustment Menu Items

Table 1-32.

Item	Panel Display	Setting Value
Right Head Bi-D Offset Setting#1 (Normal dot) Note 2)	BID OFFSET #1	-4~0~4
Ink Level Detection Note 3)	DET.ECT INK LABEL	ON OFF
MW 2 Feed Balance Note 4)	MW 7 BALANCE	-31~0~+31

Note 1): Settings with underlines show default values.

Note 2): This sets the desired offset the adjustment value in Bi-D Adjustment Pattern #3, set by the user. This mode is a function for reducing irregular color that occurs in the 720 dpi x 720 dpi and 1440 dpi x 720 dpi printing modes due to setting of the desired offset with respect to the adjustment values for Bi-D adjustment values (Bi-D adjustment pattern No. #3) for these printing modes. However, since there are cases where there is no effect even when the desired offset is set in this function, adequate caution should be exercised when changing the setting values.

Note 3): This sets whether the sensor which detects the I/C type identifier on the I/C label will detect it or not.

Note 4): If microbanding, which occurs in the 720 x 360 dpi mode and the 720 x 720 dpi mode actually occurs, this reduction function acts to reduce banding somewhat when this setting is changed. However, there may not be any effect even if the setting is set in the desired value by this function, so exercise caution when changing the setting value.

SELF-DIAGNOSTIC FUNCTION MODE

By turning the Power switch ON while pressing the following panel buttons, the self-diagnostic mode is started.

Paper Feed – Button + Cut / Eject Button + Cleaning Button

This mode is used in adjustment work, etc. when carrying out major parts replacements. For details, see Chapter 5, “Adjustments.”

1.3.6 Firmware Update

The firmware is written to the Flash ROM on the printer's main board. Thus, if the main board has had to be replaced due to repairs, or if it is necessary to upgrade the firmware version, and you are rewriting the firmware to the Flash ROM, do so by either of the following methods.

CAUTION

- **If the printer's power is turned on immediately after reloading the firmware, the initial filling operation may start, so be sure to start the printer using the following procedure.**

1. Start the self-diagnostic function when the power is turned ON.
 2. Under "Diagnostics: Parameters", select "Parameters: Update."
 3. Select "Update: Ink Parameters."
 4. Select "Reset" under "Initial Filling Flag."
 5. Turn the printer's power OFF, then turn it ON again.
- **The firmware data file differs depending on the loading method, so the correct file should be used.**
 - If through a PC: XXXXXXXX.IPL
 - If through a PC Card: XXXXXXXX.ROM

UPDATING THE FIRMWARE VIA THE PC

1. Connect the affected printer to the PC. Use the parallel interface to make the connection.
 <Parallel Connection> : Effective only for Compatible mode connection
 Turn the printer on while pressing the following buttons.
 "Paper Source" + "Eject" + "Cleaning"
2. Send the proper firmware data file to the printer from the connected PC.
 At the DOS prompt, input copy [filename] prn:".
3. Reloading of the firmware will begin and the following messages will be displayed in order in the LCD panel.
 Flash Erase → Flash Write → Complete → Program Load End
4. Turn the printer off and back on.

UPDATING THE FIRMWARE VIA MEMORY CARD

For details on this operation, see Chapter 5, "Adjustment".

1. Copy firmware data file to the PC card.
2. Remove the access cover on the rear of the printer (above paper guide U), then insert the memory card (Flash memory card) where the firmware data for reloading are recorded in the card slot (CN20).
3. Turn the printer's power ON.
4. Reloading of the firmware will start and the following messages will be displayed in order in the LCD panel.
 Flash Erase → Flash Write → Complete → Program Load End
5. Turn the printer off, remove the memory card, and turn the printer back on.

CAUTION

Whichever method is used, if the update processing is interrupted in the middle, (if the power goes off, etc.), it can be recovered by repeating this operation.

1.3.7 Jumper Settings

The factory default settings for jumper and DIP switch on the Main Board (C277MAIN) are as follows.

Table 1-33. Jumper Settings

Type	Number	Setting
Jumper	JP1	Shorted
Jumper	JP2	Shorted
DIP-SW	SWD1 "1" (1-4)	OFF (Open)
DIP-SW	SWD1 "2" (2-3)	OFF (Open)



- The above jumper settings are used for factory settings only, and should not be changed during servicing. These jumper settings determine the matching of the firmware, CPU and ASIC, etc., so if they are inadvertently changed, it will become impossible to operate the printer.
- When installing the ASP board, the DIP-switch settings should be changed as shown below. For details concerning settings, see page 100.
 - DIP-Switch Setting DIP-SW1 DIP-SW2
 - ASP Board OFF OFF
 - When board installed OFF ON

Table 1-34. Printer Status Menu (continued)

Display message	Meaning
CUTTER LIFE	Shows the remaining useful life of the cutter
TOTAL PRINTS	Shows the total number of printed documents
WASTE INK	Displays the CR motor life.
CR MOTOR	Displays the PF motor life.
PF MOTOR	Displays the head unit life.
HEAD UNIT	Displays the head unit life.
CLEANER	Displays the maintenance kit life.

See the following table concerning the display format for each item.

Table 1-34. Printer Status Menu

Display message	Meaning
VERSION	Shows the firmware version.
INK LEFT-K	Shows the amount of remaining ink - Cyan
INK LEFT-M	Shows the amount of remaining ink - Magenta
INK LEFT-LC	Shows the amount of remaining ink - Light Cyan
INK LEFT-LM	Shows the amount of remaining ink - Light Magenta
INK LEFT-Y	Shows the amount of remaining ink - Yellow
INK LEFT-K	Shows the amount of remaining ink - Black

CHAPTER

2

OPERATING PRINCIPLES

2.1 Component List & Illustrations

This section explains the print mechanism and operating principles for the EPSON Stylus Pro 9500.

2.1.1 Print Mechanism Components

The printer mechanism of EPSON Stylus Pro 9500 consists of the following mechanism parts.

Table 2-1. Print Mechanism Components

Component	Explanation
Carriage Assembly	Carriage section: <input type="checkbox"/> printheads (B head/C head) <input type="checkbox"/> PG Motor <input type="checkbox"/> Linear Encoder <input type="checkbox"/> HP sensor <input type="checkbox"/> PG sensor <input type="checkbox"/> Paper Width sensor <input type="checkbox"/> Paper cutter-drive component
	Carriage guide rail section: <input type="checkbox"/> CR Motor
Paper Feed Mechanism	Paper feed rail: <input type="checkbox"/> Grid roller assembly <input type="checkbox"/> Secondary roller assembly (opposite the grid rollers) <input type="checkbox"/> PF Motor (Rotary Encoder internal part)
	<input type="checkbox"/> Paper Suction Fans <input type="checkbox"/> P_FRONT Sensor (detects front edge) <input type="checkbox"/> P_REAR Sensor (detects rear edge) <input type="checkbox"/> Paper Thickness Sensor <input type="checkbox"/> Paper Release-Lever Position Sensor
Cleaning Assembly	<input type="checkbox"/> Pump Assembly/Pump Motor <input type="checkbox"/> Cap Assembly <input type="checkbox"/> CR Lock Mechanism

Table 2-1. Print Mechanism Components

Component	Explanation
Ink Delivery System	I/C Holder Assembly <input type="checkbox"/> Ink Cartridge Holder/Valve Mechanism <input type="checkbox"/> I/H Lever Position Sensor <input type="checkbox"/> Ink Cartridge Detect Sensor <input type="checkbox"/> Ink Low Sensor <input type="checkbox"/> Ink ID Sensor
Other	Cover Position Sensor (interlock switch)

CARRIAGE COMPONENTS

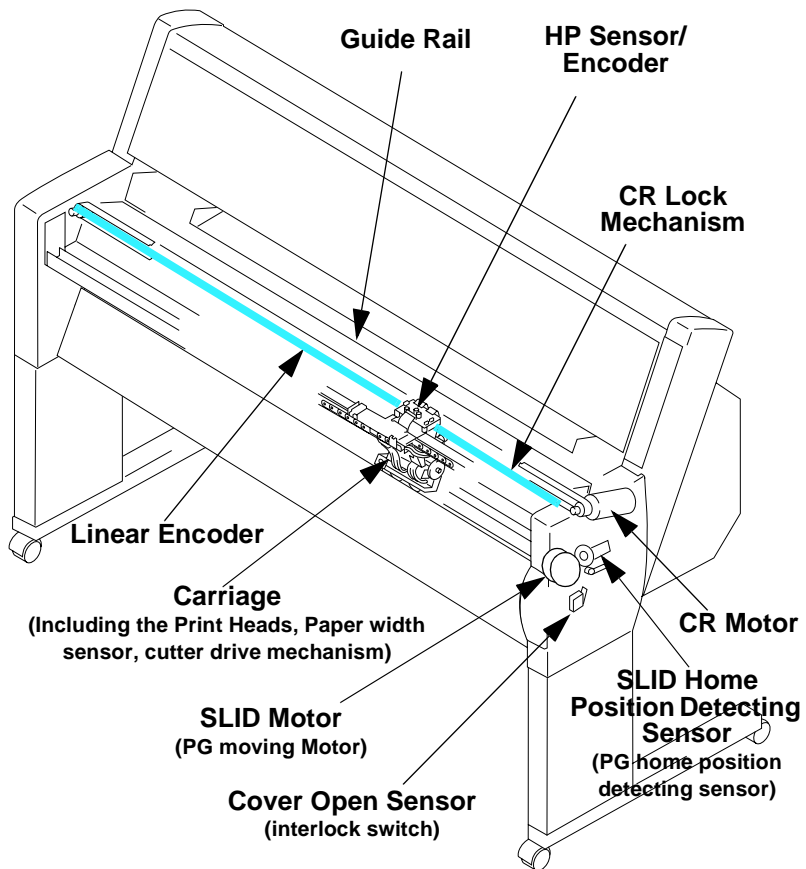

Figure 2-1. Carriage Components/Main Parts

PAPER FEED PATH & COMPONENTS

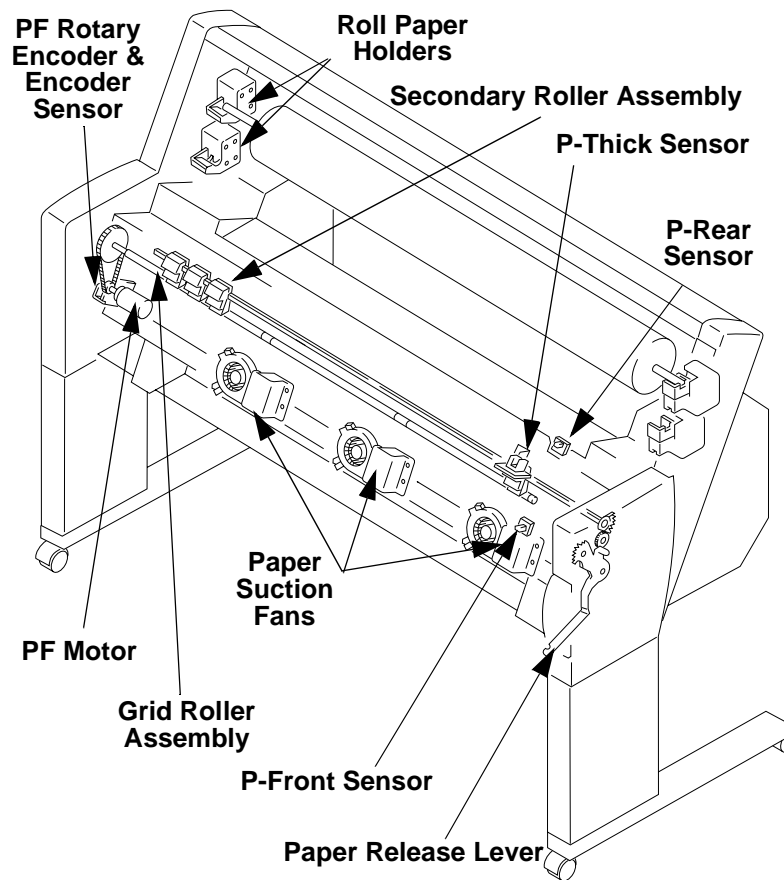

Figure 2-2. Paper Feed Components/Main Parts

INK SYSTEM COMPONENTS

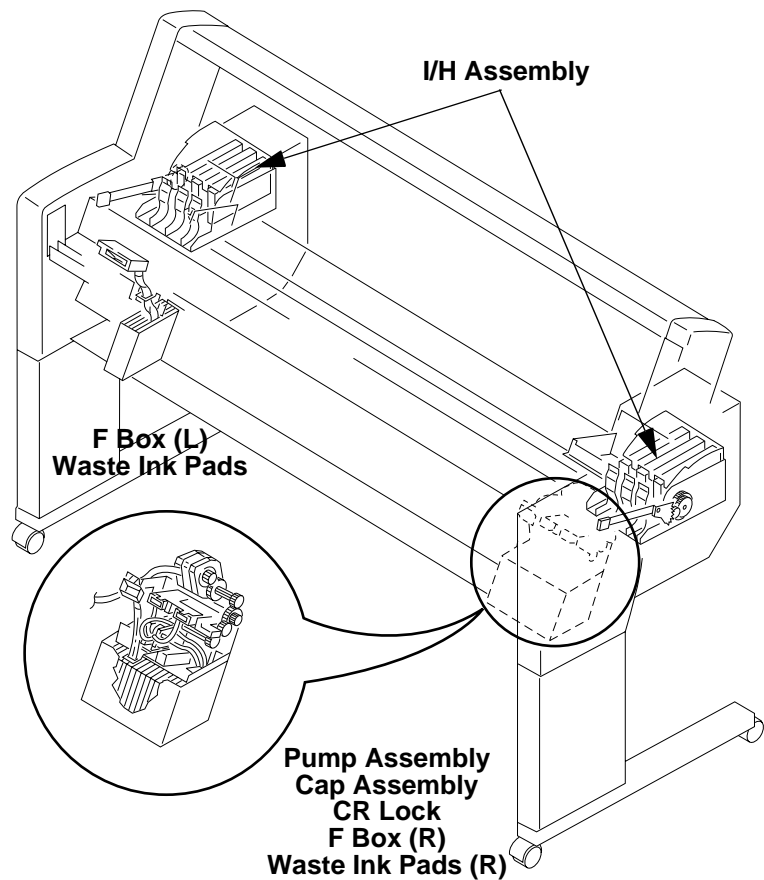

Figure 2-3. Ink System - Main Parts

ELECTRICAL CIRCUIT BOARDS

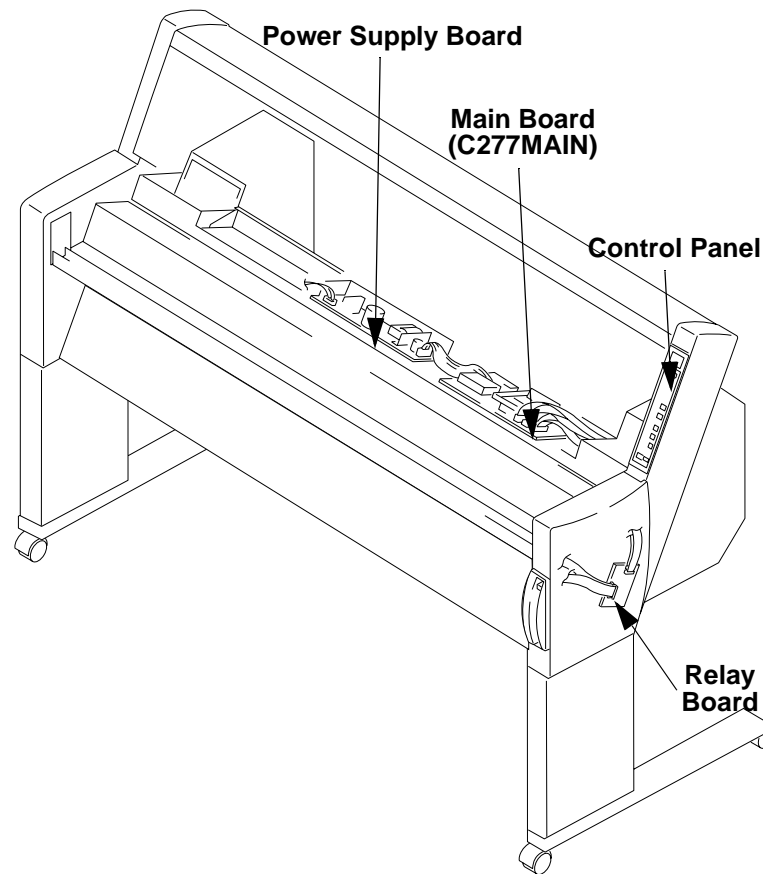

Figure 2-4. Electrical Circuit Boards

2.1.1.1 Carriage Mechanism

CR GUIDE RAIL

To print on paper as wide as B0 Wide, the printhead carriage must be more stable and must travel further than the usual carriage. To make the printheads more stable, EPSON added the CR Guide Rail to the SP 9000.

Every EPSON ink jet printer until now has used a carriage guide shaft to stabilize the carriage during printing and horizontal movement. SP 9000 does away with the carriage guide shaft and relies on the printer frame for its stability.

The CR motor uses a DC motor to move the carriage, and the Linear Encoder determines the lateral position of the carriage by counting the shaded areas of the plastic Step Ruler (timing fence). See Figure 2-5 below. The Linear Encoder reads the shaded stripes to determine the position of the carriage as well as the carriage speed, and this data is sent to the software servo. To allow for the extra distance the carriage must travel during printing, the rubber timing belt has been changed to a belt made from steel.

The following sensors are used in combination with the CR Guide Rail components:

- HP Sensor
This optical sensor activates when the CR Guide Rail flag (flag) enters the space between the light emitter and the light receiver. The flag is located just above the home position, and the HP sensor sends an “On” signal when the carriage is in the home position.
- Linear Encoder
This encoder is mounted on the back of the carriage and outputs pulses corresponding to the position of the slits in the timing fence that is incorporated into the CR guide rail which are used for CR motor software servo control and PTS (Print Timing Signal) generation. This linear encoder has a 2-channel digital output format, with phase A and phase B, and the resolution of each phase is 1/180 inch. Each phase is output so that it deviates 1/720 inch from the other phase and if full edge output of both phases is used, the minimum resolution is 1/720 inch. The CR moving direction is monitored by the CPU through the combination of the phase A and phase B output waveforms.

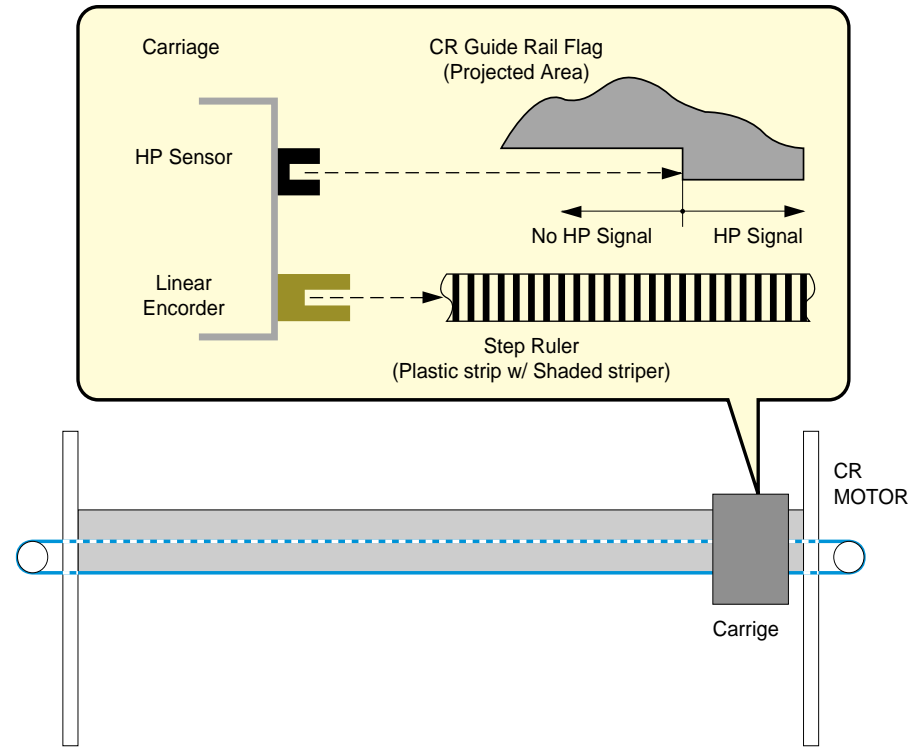

Figure 2-5. Carriage Mechanism & CR Guide Rail

CARRIAGE UNIT CONFIGURATION

In this printer, a carriage holding and drive mechanism construction which differs from previous models is used. The carriage configuration consists of the following major parts.

- Base Carriage :1unit
- Sub-carriage :1unit
- Print Heads :2 units (Dark system, Light system heads)
- Slide Eccentric Cam, Slide Gear

The mounting position of the base carriage is maintained at a constant distance with respect to the paper surface at all times. Consequently, in order to enable changes in the gap between the paper printing surface (platen surface) and the head nozzle surface, a sub-carriage is mounted on the base carriage to which the print heads are fastened.

The sub-carriage is mounted on the base carriage in a state where it can move in the vertical direction with respect to the paper surface by means of the SLID eccentric cam, which is driven via the SLID gear. Through this mechanism, the construction is such that the print heads can move to the set gap position.

Vertical movement of the sub-carriage with respect to the paper surface is possible only in the case that the carriage is in the home position (HP). At that time, the SLID motor pinion gear (PG moving motor) and the SLID gear mounted on the SLID eccentric cam shaft engage, and the SLID cam is driven by the SLID motor's rotation, causing the sub-carriage (including the print heads) to be raised or lowered to the proper gap position.

The print heads used in this printer are the same as those used in the Stylus Pro 5500 and Stylus Pro 9000, and the head mounting method on the sub-carriage also has the same construction. Therefore, if the print heads are removed or installed, or replaced, it is necessary that the respective inclinations and of the dark system head/light system head in the horizontal direction (carriage scanning direction) and the light system head nozzle height with the dark system head nozzle position as the reference in the vertical direction (paper transport direction) be set with the adjustment lever. For details, see Chapter 5, "Adjustments."

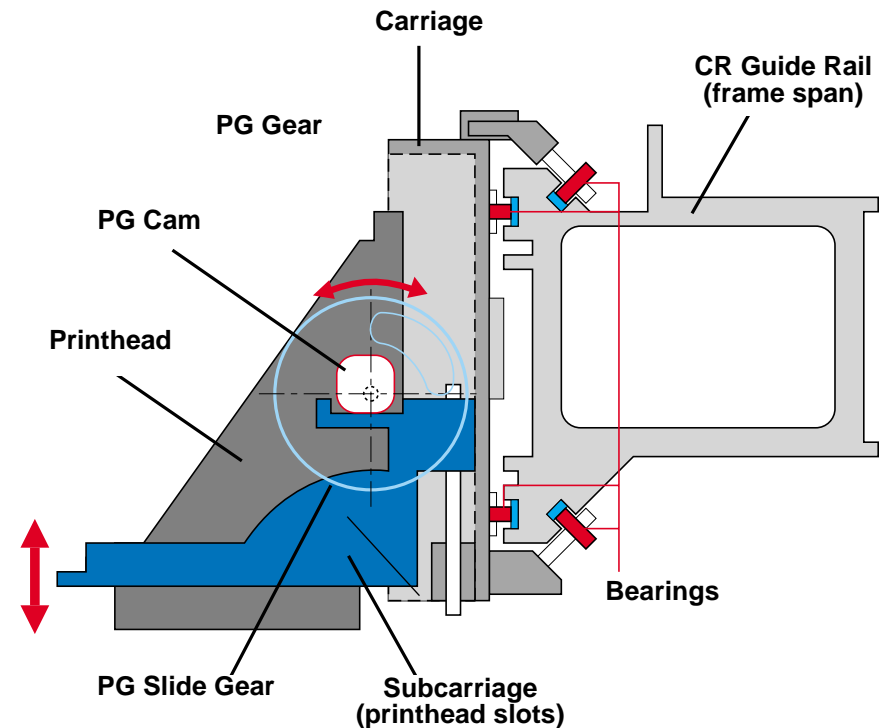

**Figure 2-6. Carriage Mechanism & CR Guide Rail
(View from the printer's right side)**

CARRIAGE DRIVE MECHANISM

Driving of the carriage is accomplished using a DC motor which is controlled a software servo through the means of a linear encoder. Basically, in the control circuit, the torque calculation processing necessary for motor drive based on carriage drive commands (position commands) is carried out and the motor is excited and driven by the PWM output. Then the carriage position movements executed by motor drive are fed back by signals generated by the linear encoder as carriage position information and moving speed information for the position commands and the carriage is controlled so that it moves at a constant velocity.

□ Print Control

Carriage drive speeds i print operations are as shown below.

Table 2-2. Carriage Speed

Print Mode	Carriage Speed	Head Drive Frequency
180 dpi (1 dot printing)	33.3 IPS	6.0 KHZ
180 dpi (2 dot, 4 dot printing)	24 IPS	4.2 KHZ
360 dpi (1 dot printing)	24 IPS	8.6 KHZ
360 dpi (2 dot printing)	24 IPS	8.6 KHZ
720 dpi (1 dot printing)	24 IPS	17.3 KHZ
720 dpi (1 dot 2 pass FOL printing)	33.3 IPS	12 KHZ
1440 dpi (1 dot 2 pass FOL printing)	24 IPS	17.3 KHZ
1440 dpi (1 dot 4 pass FOL printing)	33.3 IPS	12 KHZ

Printing operations can be executed at the point when the carriage has traveled 10 mm at a stable constant velocity after acceleration control.

□ Stop Control

Carriage stop control is executed at the point when acceleration - constant velocity - deceleration control processing is completed and is controlled by position control through the software servo and a stabilization time (in position time) at the stop position.

□ CR Motor Trouble Detection

If the difference between the specified position given to software servo control and the current carriage position read by the linear encoder exceeds the specified number of pulses generated, a fatal error (CR Motor out of Synch: Service Call 00010005) occurs.

PAPER WIDTH DETECTION SENSOR

This sensor is mounted on the sub-carriage and detects the paper's left and right edge positions, identifying the paper width and judging if the paper is skewed.

If it recognizes that there is paper present, its output voltage is raised and if it recognizes that there is no paper present, its output voltage drops.

Table 2-3. Paper Width Detection Sensor Detection Modes

Paper	Output Voltage
Present	Voltage rises.
Not Present	Voltage drops.

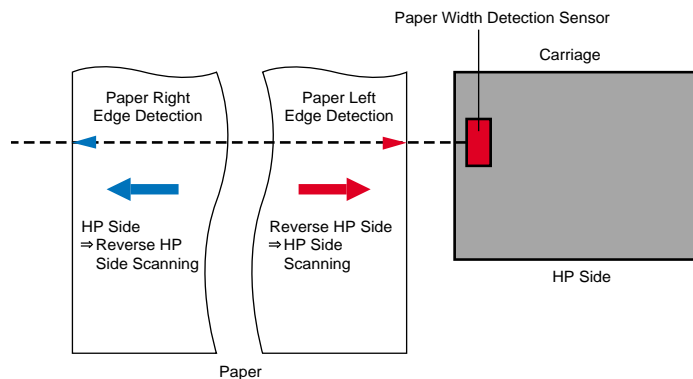

Figure 2-7. Carriage Unit Paper Width Detection Sensor

A reflective type photosensor is used and the paper edge (paper present or not) is judged by the 10-bit A/D converted value output by the sensor.

Detection of paper skew occurs in the following case and causes the message "Set the paper correctly." to be displayed in the LCD.

- If the front edge and back edge of a cut sheet are skewed more than 3 mm left to right.

PG SETTING MECHANISM

In order to maintain the distance between the print head nozzle surface and the paper constant in correspondence with the thickness of the paper used, a mechanism is incorporated into this printer's carriage which enables the print head position to be set in 3 stages in the height direction as viewed from the paper surface. The PG home position is detected by the LID home position detection sensor mounted on the right frame and the SLID gear.

A reflective type photosensor is used in the SLID home position detection sensor, and this detects the position of the notch in the SLID gear and make that the home position.

The mechanism is configured so that when the sub-carriage is in the lowest position, the sensor's output is "OFF," and the point when, during the detection operation, the head drops down from its position after rising up, and the sensor's output changes from "ON" to "OFF," is recognized as the mechanical PG home position (PG = small).

Changes in the PG value from the PG home position are implemented by the following operation

- PG home position → SLID motor pinion gear rotates CCW (Note) → SLID gear → SLID gear shaft rotates CCW → SLID eccentric cam rotates CCW → Sub-carriage moves up (PG becomes wider).

Note): CCW rotation is the rotational direction shown if you are looking from the printer's right side.

The SLID eccentric cam is eccentric in 3 stages and the following 3 stages of PG value setting are enabled by the number of SLID motor CCW rotation steps in the above operation.

Table 2-4. SLID Home Position Detection Sensor Detection Mode

PG Value	Slide Gear Notch Position	Sensor Output	Output Voltage
Small (1.4 mm)	Down (Left figure right)	OFF	2.0 V or lower
Medium (2.3 mm)	Right	ON	2.0 V or lower
Large (2.8 mm)	Up (Left figure left)	ON	3.0 V or higher

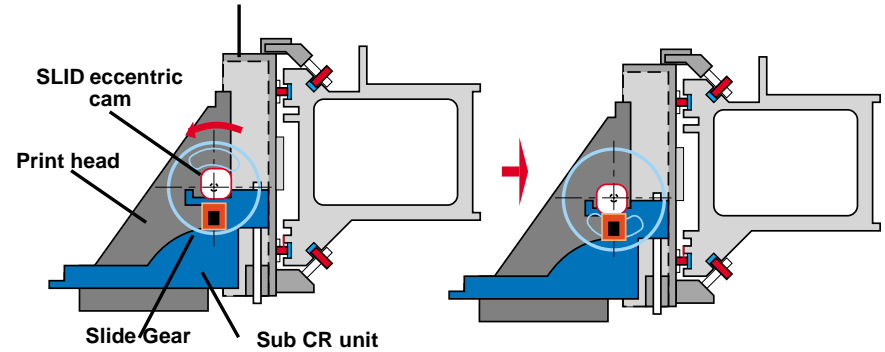

Figure 2-8. SLID Home Position Detection Sensor (PG Home Position Detection Sensor)

Also, the actual PG value during printing is one of the following setting values determined by the combination of the panel setting (Auto;, Widen), command setting (default PG/PG large), and paper thickness detection sensor (thick paper/thin paper) (Note).

Table 2-5. PG Position - Panel Setting / Paper Thickness

Panel PG Setting	Command Setting	Paper Thickness Detection Sensor	PG Position
Widen	PG Large	Thick Paper	PG Large
		Thin Paper	PG Large
	Default PG	Thick Paper	PG Large
		Thin Paper	PG Medium
Auto	PG Large	Thick Paper	PG Large
		Thin Paper	PG Large
	Default PG	Thick Paper	PG Large
		Thin Paper	PG Small

Note): See concerning the paper feed mechanism about the paper thickness detection sensor.

CUTTER SOLENOID

This solenoid is mounted on the side opposite the HP and the cutter for cutting roll paper moves up and down by it. In order to prevent deviation due to the paper curling up at the position where it is cut off during a cutting operation, the cutting operation is performed in the following sequence.

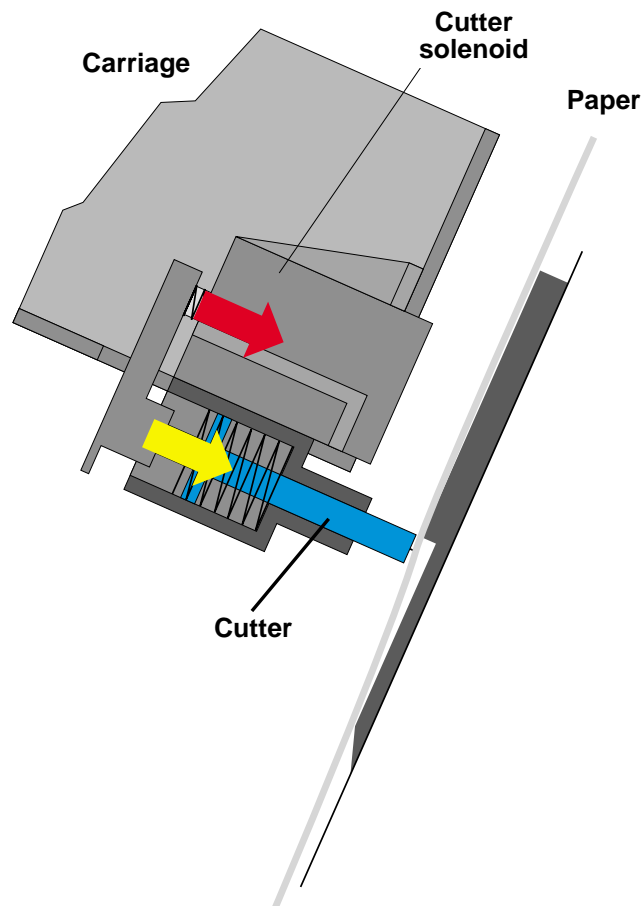

Figure 2-9. Carriage Unit - Cutter Solenoid

There are 2 methods used, which correspond to paper cutting conditions.

- 3-stage Cutting
 - Cutting Conditions:
 1. Cutting after printing and by resetting during printing.
 2. Manual cutting during printing
 3. Turning Auto Cut on after printing following Auto Cut Off, then manual cutting.
- Cutting Method
 - 1st Stage:

From a position 60 mm to the left of the paper's center, cut to a position 8 mm beyond the paper's left edge (from right to left).
 - 2nd Stage:

From a position 30 mm to the left of the paper's right edge, cut to a position 8 mm beyond the paper's right edge (from left to right).
 - 3rd Stage:

From a position 22 mm to the left of the paper's right edge, cut to a position 68 mm to the left of the paper's center (from right to left).
- 4-stage Cutting
 - Cutting Conditions:
 1. Paper is present at the top edge sensor, and when the paper set lever is lowered, manual cutting is done by pressing the "Cut/Eject" button.
 2. Manual cutting while in the normal standby state.
 3. Manual cutting after forward paper feed.

■ Cutting Method

1st Stage:

From a position 60 mm to the left of the paper's center, cut to a position 8 mm beyond the paper's left edge (from right to left).

2nd Stage:

From a position 60 mm to the right of the paper's center, cut to a position 8 mm beyond the paper's left edge (from left to right).

3rd Stage:

From a position 68 mm to the right of the paper's center, cut to a position 40 mm to the right of paper's center (from right to left).

4th Stage:

From a position 68 mm to the left of the paper's center, cut to a position 48 mm to the right of the paper's center (from left to right).

CR LOCK MECHANISM

This mechanism uses a magnetic solenoid, and when the carriage is in the standby state in the HP position, (CR motor excitation OFF), it locks the carriage's position. When the carriage is in the locked state, power to the carriage is turned OFF, the actuator rises up and a projection engages with the back surface of the carriage, binding the carriage. When carriage lock is released, power to the carriage is turned ON, the actuator is withdrawn from the carriage and the lock engagement is canceled.

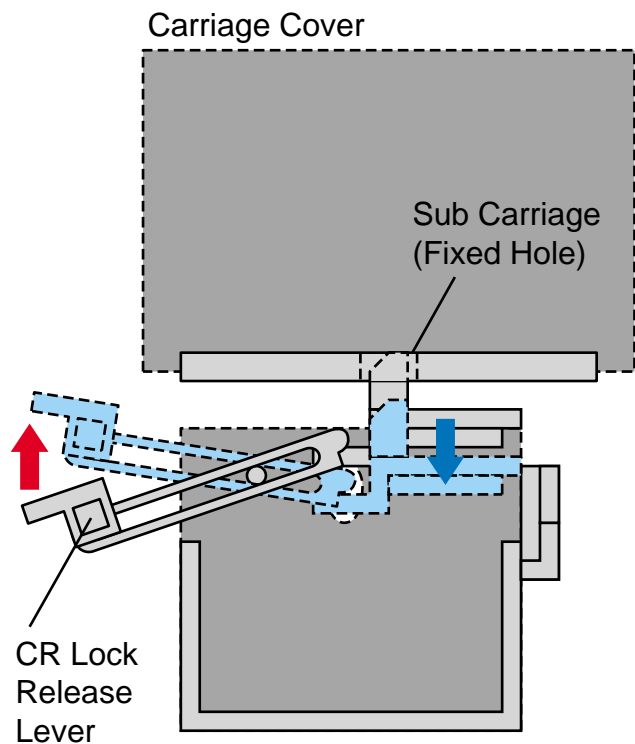

Figure 2-10. CR Lock Mechanism

2.1.1.2 Paper Feed Mechanism

PF RAIL UNIT

The paper transport mechanism is made of the same extruded aluminum material as the CR guide rail and consists of a grid roller (PF roller) mounted on the PF rail and the pressurization and follower roller assembly mounted opposite to it on the back of the CR guide rail. The grid roller (PF roller) in the Stylus Pro 9500 differs from the grid roller (PF roller) in the Stylus Pro 9000, in that there is only one. (In the Stylus Pro 9000, there are 3 fixed length rollers lined up across the breadth of the printer, linked together with a coupling construction, and fastened to the PF rail via bearings.)

A CD motor is used for the PF motor and this motor is software servo controlled based on pulses output from an optical rotary encoder. In the Stylus Pro 9000, an encoder sensor and loop scale are built into the PF motor, but in the Stylus Pro 9500, the PF motor and encoder sensor/loop scale are separate units, with the loop scale mounted at the left end of, and concentric with the PF roller and the encoder sensor also assembled separately in the printer's left edge.

Driving of the PF roller is done by transmission to the PF roller through the following channel.

- PF motor pinion gear _ Timing belt _ Reduction pulley _ Grid roller (PF roller)

Suction fans are also mounted on the back side of the paper guide L (the space in back of the paper guide L is divided into 3 cavities arranged side by side across the width of the printer with one suction fan mounted in each cavity), and by these fans pulling air from the back side of the paper and out through the printer body, a suction force is applied to the paper guide L's surface which acts to stabilize paper travel (preventing it from lifting up). Furthermore, the air volume is controlled by firmware (fan rotation duty control) based on the printer's operating state (when paper is set, during printing, etc.).

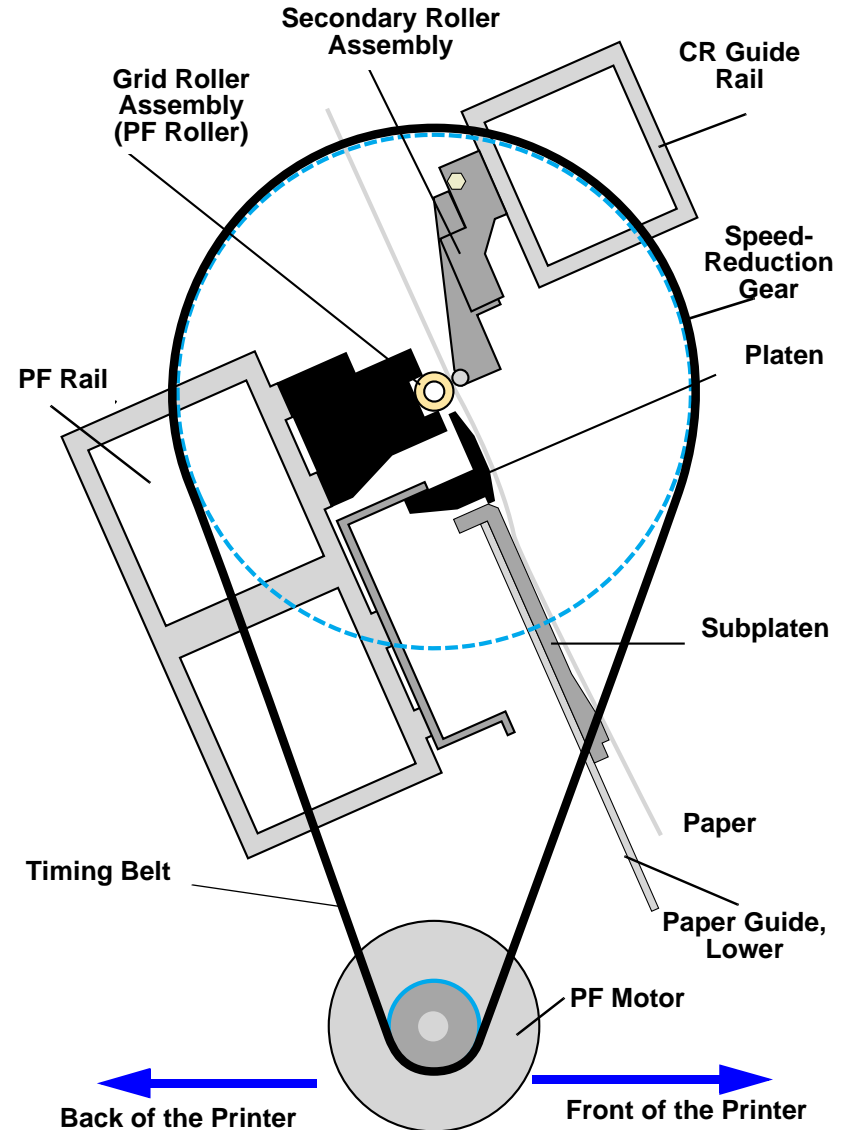

Figure 2-11. Paper Feed Mechanism - PF Rail Unit

SENSORS

The following sensors and mechanisms are mounted in the paper transport path.

□ P-FRONT Sensor

A reflective type photosensor is used for this sensor, which is mounted on the back of the paper guide L. This sensor's detection state is used as the reference point for the paper's position control in the paper feed direction (top of form during the paper set initialization operation, etc.). When there is paper present, the voltage rises and when there is no paper, the voltage drops.

□ P-REAR Sensor

A reflective type photosensor is used for this sensor, which is mounted on the back of the paper guide U. This sensor senses when the printer is out of paper by detecting the rear edge of the sheet and starts the paper setting operation (starting the suction fans, etc.) by detecting the front edge of the paper when the paper is set. Just like the P-FRONT sensor, its voltage rises when paper is present and drops when there is no paper.

□ Paper Thickness Detection Sensor

A transmissive photosensor is used for this sensor, which is mounted on the H top guide. A detection lever is mounted on the pressurization and follower roller assembly on the HP side and the detection lever position, which changes according to the thickness of the paper inserted between the grid roller (PF roller) and follower roller is detected by this sensor.

Table 2-6. Paper Thickness Detection

Paper Type	Paper Thickness *1	Sensor output	Output Voltage
Thin Paper	0.6 mm or less	ON	0.7 V or higher
Thick Paper	0.7 mm or greater	OFF	2.4 V or higher

Note) It is not definite which type of paper a sheet of paper with a thickness of 0.6 ~ 0.7 mm will be detected as.

□ Paper Set Lever Detection Sensor

A transmissive type photosensor is used for this sensor. It detects the flag position on the rear edge of the paper set lever mounted on the right side frame. When the paper set lever is in the set state (Paper Set position), the sensor's output is "HIGH."

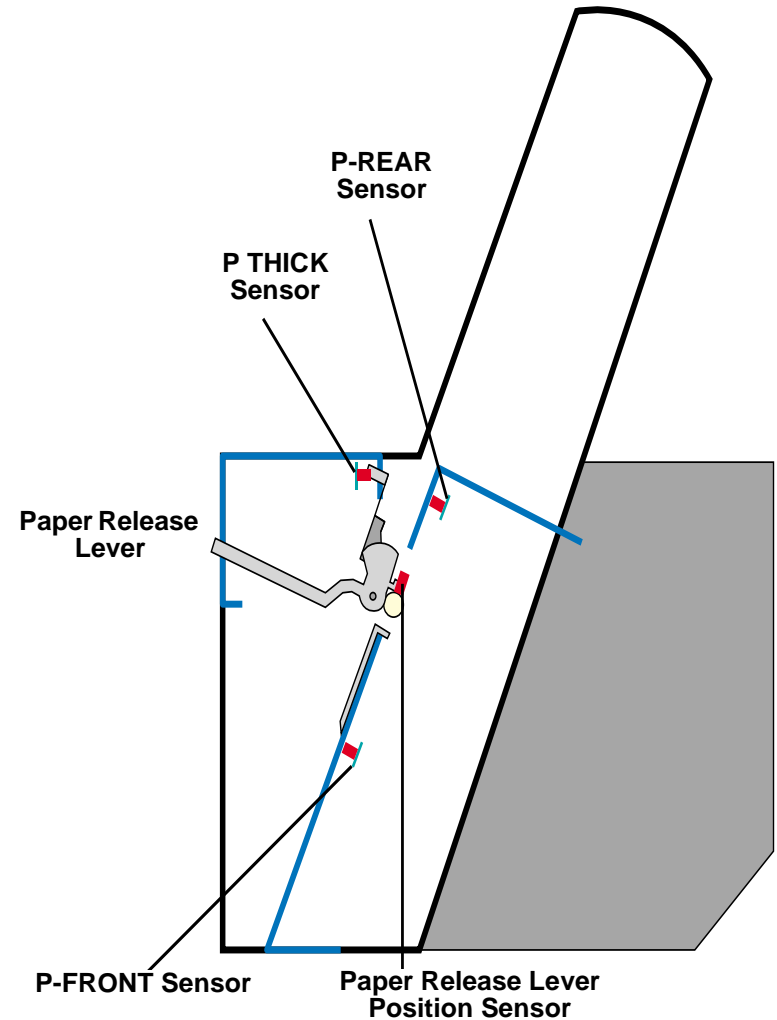

Figure 2-12. Paper Feed Mechanism - Sensors

PAPER FEED CONTROL

In this printer, only roll paper and cut sheet paper can be used due to its friction feed system. The printer's status is detected by various sensors mounted along the paper feed path and fed back to paper feed control.

□ Paper Suction Fan Control

In order to provide assistance during setting of paper and stabilize paper feeding during print operations, the three paper suction fans mounted behind paper guide L pull on the paper from the back side of the sheet. The fans are run at a constant velocity during printing, but when the paper is set, the following control is carried out to improve setting characteristics. Suction fan air flow control is carried out based on the paper sensing timing of the P-Rear sensor and the P-Front sensor. Detailed control methods are as shown below.

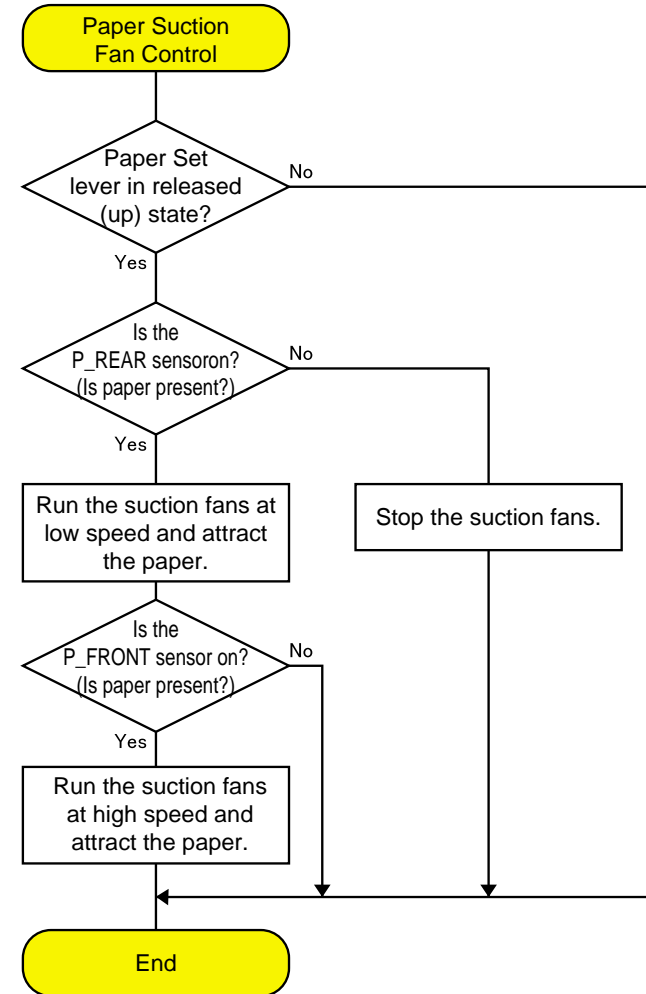

Figure 2-13. Paper Suction Fan Control

Table 2-7. Suction Fan Air Flow Control

State	Air Flow Duty (%)	
	Cut Sheet	Roll Paper
Standby States other than the following	0	0
During paper setting (P-REAR sensor detected.)	50	50
During paper setting (P-FRONT sensor detected.)	80	80
During initialization with the paper set.	100	100
During printing (up to 30 mm of the front edge)	10	10
During printing (30 mm of the front edge or more, but 40 mm or less of the front edge.)	50	100
During printing (after the first 40 mm of the front edge)	100	100
Cleaning with the paper set.	100	100
During paper cutting	---	100

□ Paper Size Sensor Control - Left, Right Edge Detection

Sensing of the size of the paper set in the printer is done through the paper left, right and front edge detection sequence.

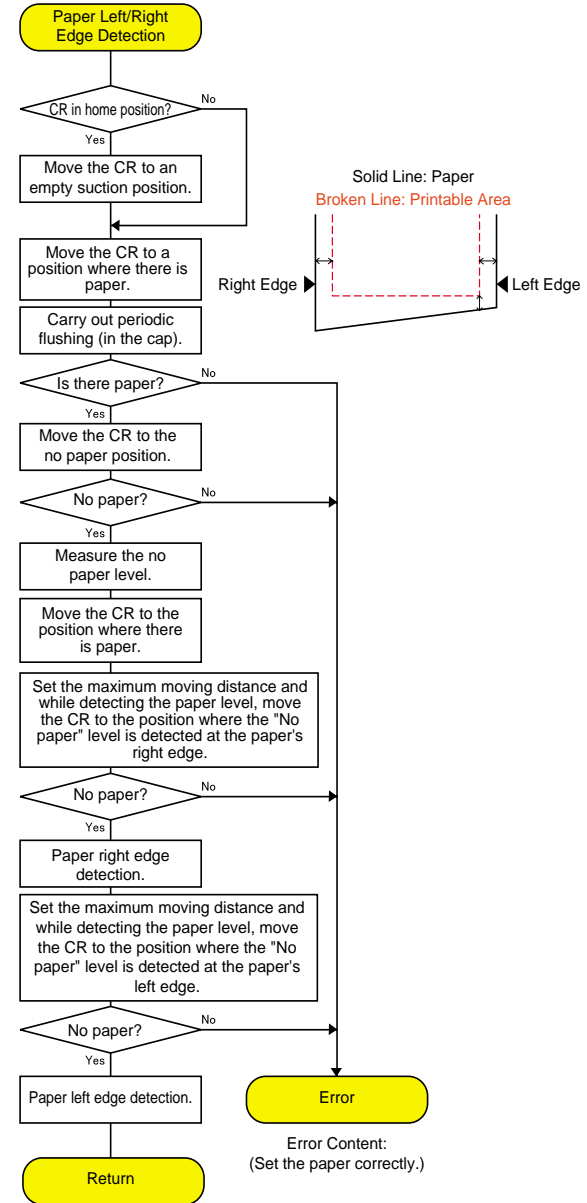

Figure 2-14. Paper Size Sensor Control - Left, Right Edge

□ Paper Size Sensor Control - Front Edge Detection

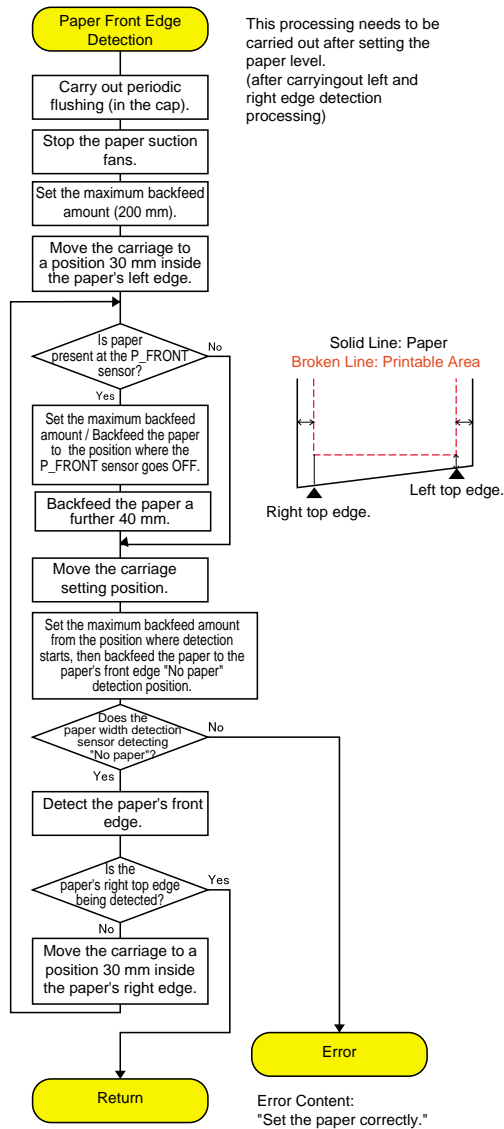

Figure 2-15. Paper Size Sensor Control - Front Edge Detection

□ Paper Setting State Detection

If something abnormal is detected in the paper setting position check (left, right edge and front edge detection) performed during initial processing when paper is set in the printer, it results in an error with the message "Set the paper correctly." being displayed.

■ Reference

The reference hole array for lining up the paper's left edge on the paper guide L (the right edge of the paper when viewing from the front of the printer) is made the mechanical reference home position for judging the paper position.

■ Judgment Standard

Positional deviation of 10 mm or greater in the left and right directions from the reference hole array (center) is regarded as an error.

□ Paper Skew Judgment

The paper skew (inclination to the side) judgment is made with the left and right edge detection position during form feeding of each printed page as the reference. Therefore, if skewing occurs with a certain printed page, after that page is printed, an error occurs at the front edge position of the next page to be printed (the rear edge position of the previous page) and the message "Paper is skewed" is displayed.

■ Reference

Edge position detected during paper left, right edge detection.

■ Judgment Standard

If there is deviation to the left or right exceeding 3 mm between the front edge and rear edge of the paper (the front edge of the next page), it is regarded as an error.

2.1.1.3 Cleaning Mechanism

This printer's cleaning mechanism has the same mechanical configuration as that in the Stylus Pro 5500 and Stylus Pro 9000. (However, it differs in its component parts. See below for details.) The major component parts are described below.

Pump Assembly (Cleaner, head installation)

Suction of ink from the head nozzle through the cap is used to accomplish cleaning. Through rotation of the pump wheel, and by pressing the ink tubes connected to the cap, the internal pressure change accompanying the change in the tubes' internal volume causes the ink to be sucked up.

Pump Drive Motor (Stepping Motor)

This is an exclusive motor that drives the pump assembly.

Cap Assembly (Independent type for the dark system head and the light system head)

This protects the print head nozzles when they are not operating and seal off the head nozzle surfaces during the cleaning operation. The cap assembly in the Stylus Pro 9500 uses new tubes to reduce evaporation of the moisture in the ink.

F Box R

This is a receptacle for the ink that is discharged during flushing, with the ink being discharged to the waste ink tank. In order to carry out flushing on the side opposite the HP side, the F box L and waste ink tank (L) are also provided separately. As for flushing in the Stylus Pro 9500, in order to prevent mist from forming on the head nozzle surface during flushing and in order to prevent the mist from condensing on the flushing box discharge outlet, a construction with a new part (bell eater) added has been adopted.

Each of the above units is mounted on the sub-frame and fastened to the main frame. (However, the F box L is a separate unit.) The CR lock mechanism is also mounted on this sub-frame.

2.1.1.4 Ink Supply Mechanism

The two ink cartridge holders each hold three cartridges, K, C, and M on one side and Lc, Lm, and Y on the other side. The design of the holders makes it quite easy to install and replace ink cartridges from the front of the printer. The I/H Lever opens and closes the I/H door, and at the same time it changes the angle of the Ink Cartridge Holder Assembly as shown in Figure 2-16, "Ink Supply Mechanism". To prevent users from accidentally installing a color ink cartridge in the wrong slot, the cartridges have slightly different designs. Stylus Pro 9000 dye ink cartridges have the same physical shape, so they can be inserted in each color's ink cartridge slot, but in order for the ink cartridge's type to be distinguished by the ink ID sensor, the message "Replace ink cartridge" is displayed in the LCD panel and printing is not possible. See "I/H Assembly Sensors" on page 64 concerning sensor details.

Another important feature of the ink cartridge holders is the ink valve, which is located on the outer sides of the ink cartridge holders and shuts off the flow of ink during printer transportation. The valve close under the following conditions:

- The user turns the valve to the "CLOSE" position to transport the printer.
- The I/H lever is lifted to the up/cartridge install position.

The ink flows out of the ink cartridges, through stainless steel pipes, through ink tubes, and finally into the printheads.

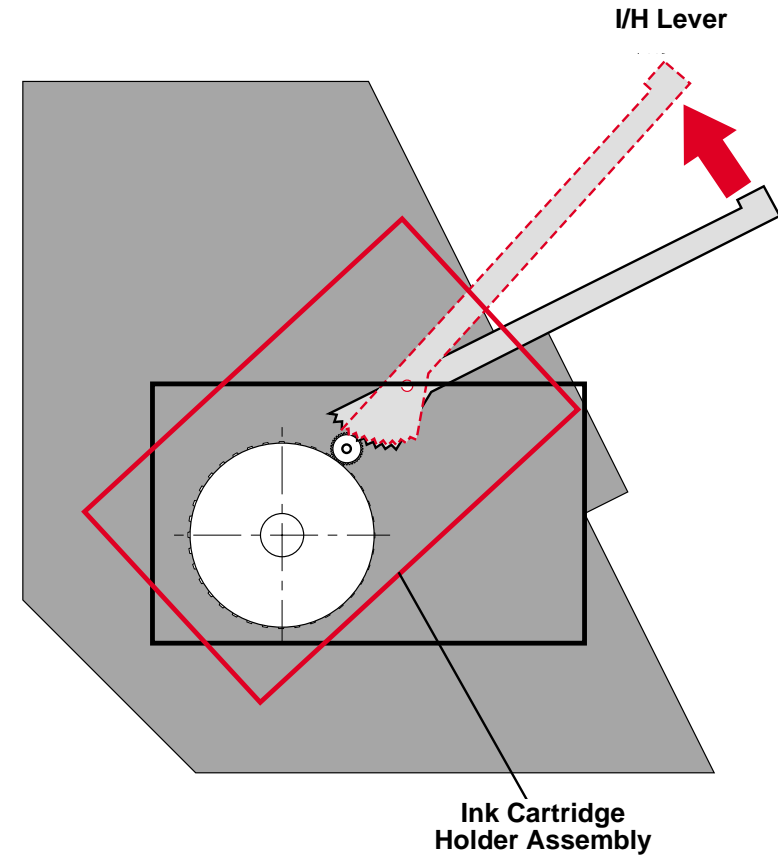

Figure 2-16. Ink Supply Mechanism

I/H ASSEMBLY SENSORS

The following sensors are located in the I/H compartment.

- I/H Assembly sensor
This optical sensor detects the whether the door is open and the I/H Assembly is in the install position or the door is closed and the I/H Assembly is in the print position.
When the I/H door is open, the signal = ON
When the I/H door is closed, the signal = OFF
- Ink Cartridge sensor
This mechanical sensor (microswitch) is built in all six ink cartridge slots.
When the I/C is installed, switch = closed
When the I/C is not installed, switch = open
- Ink Low sensor
This mechanical sensor (microswitch) is at the bottom of all six ink cartridge slots and detects when ink is running out.
When the I/C is nearly empty, the switch = open
When the I/C is not low (normal), the switch = closed
- Ink ID sensor
This optical sensor is located at the side of all six ink cartridge slots and detects the which market the cartridge is for. Although not implemented currently, the sensor can also detect the type of ink (presently dye only) and the type of special color (if new colors are introduced in the future). The Ink ID sensor looks for the following marks on the ink cartridge.

Market:	No mark, white = Overseas/Global
Ink type	No mark, white = dye-based ink
Special color	No mark, white = N/A (may be available in future)

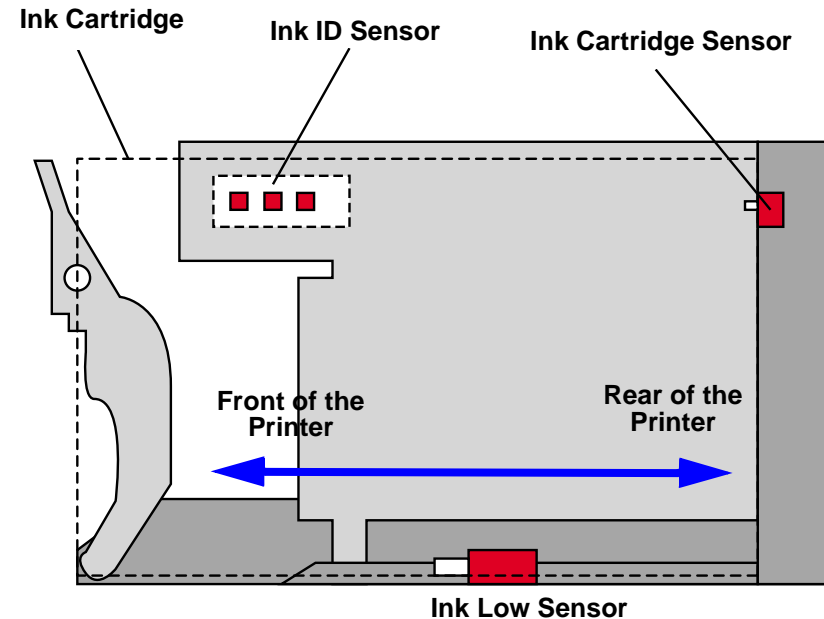

Figure 2-17. Ink Cartridge Holder Sensors

2.1.1.5 Cover open sensor

To ensure proper paper feeding and to prevent paper jams, the front cover must be closed during printing. There are two cover open sensors, one on each side of the printer, that detect when the cover is open using an interlock switch. When the cover is open, the relay that controls the current to the CR motor and PF motor cuts off the flow of that current. The motors lose their electromagnetized state when the current is cut off.

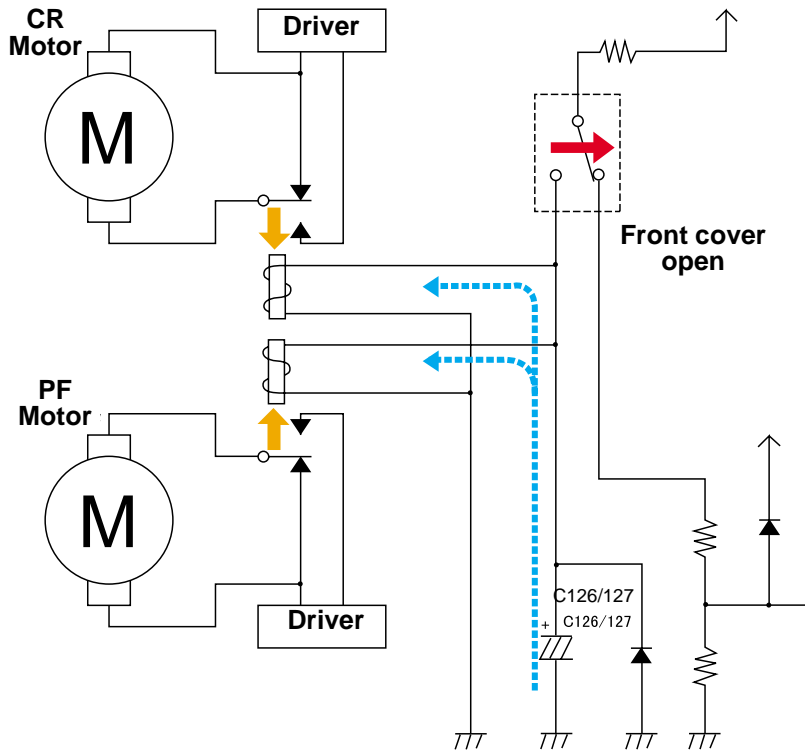

Figure 2-18. Cover Open Sensor

The sudden loss of current to the motors can cause problems and may even damage the motors or the printhead. To prevent this, a discharge from the capacitor connected to the current circuit is used to slow down the current before it is totally cut off. This process ensures that printing stops when the cover is open without causing any damage to printer parts.

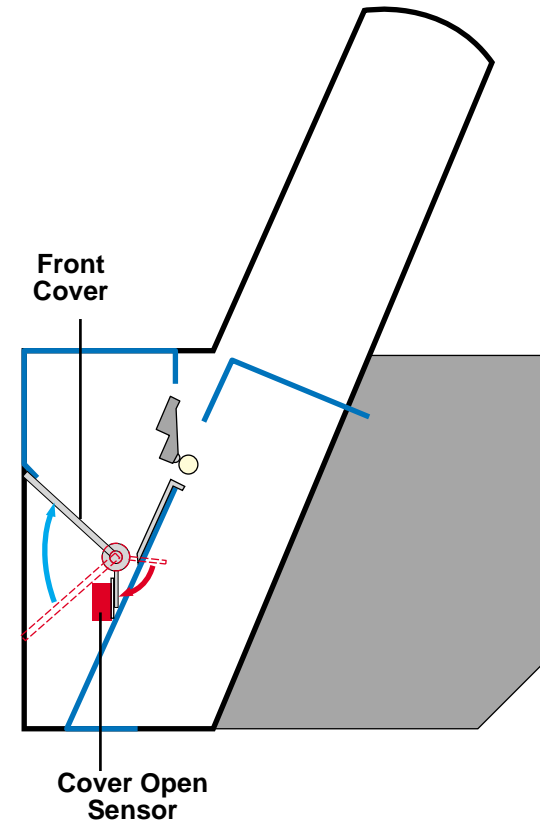

Figure 2-19. Cover-Open-Motor Control Circuit

2.1.2 Summary of Control Circuit Operations

This section summarizes the functions of the (C277MAIN) Main Board and the controls used to operate the printer.

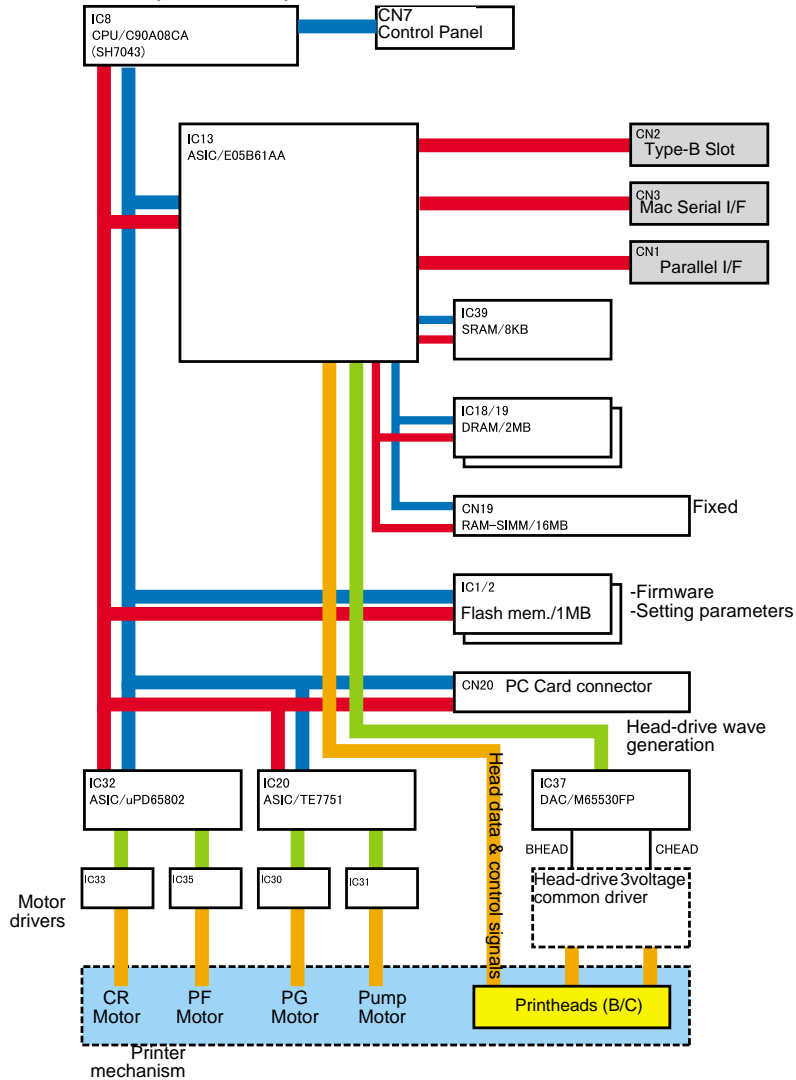

Figure 2-20. C277MAIN Board-Circuit Block Diagram

Table 2-8. C277MAIN Board Main Components

Name/Code	Location	Function
CPU (C90A08CA) SH7043	IC8	32 bit RISC-CPU <input type="checkbox"/> Clock speed = 33MHz <input type="checkbox"/> 128KB PROM internal
ASIC (E05B61AA)	IC13	1) Regulates print data <input type="checkbox"/> Command handling <input type="checkbox"/> Rasterizer (image data handling) <input type="checkbox"/> Head drive regulation (DAC) <input type="checkbox"/> Print timing regulation 2) Memory (DRAM/SRAM) 3) I/F Circuit Control <input type="checkbox"/> Parallel interface (IEEE1284) <input type="checkbox"/> Macintosh Serial interface <input type="checkbox"/> Type-B
ASIC (TE7751)	IC20	Regulates Motor <input type="checkbox"/> Pump Motor <input type="checkbox"/> PG Motor (PG setting) <input type="checkbox"/> Fan (PS, Paper Suction)
ASIC (uPD65802)	IC32	Regulates motor (PWM regulation) <input type="checkbox"/> CR Motor <input type="checkbox"/> PF Motor
DAC (M65530FP)	IC37	3 channel 10 bit DA converter <input type="checkbox"/> head-drive voltage control
Flash Memory (MBM29F400TC)	IC1/2	Flash Memory (1Mbyte) <input type="checkbox"/> Save firmware <input type="checkbox"/> Register setting parameters
DRAM (EDO)	IC18/19	EDO RAM <input type="checkbox"/> 2Mbyte <input type="checkbox"/> 16Mbyte (CN19 mounted SIMM)
SRAM (LC3564SM-10)	IC39	64Kbit SRAM <input type="checkbox"/> External data ring buffer type
Driver IC (L6203)	IC33/35	CR/PF Motor Driver
Driver IC (LB1845)	IC30/31	PG/Pump Motor Driver

2.1.2.1 Reset Circuit

The Reset-IC (IC7/BH6150F) used in the C277MAIN board has two built-in reset circuits, each of which detects input voltage and power supply voltage respectively as shown in the diagram on the right.

Pin 2 detects the voltage level of the head driver, using the input terminal of the input voltage detection circuit. The voltage level to be detected is preset at 1.25V. When the preset voltage level is detected, the Pin 2 sends a reset signal to reset the mechanism control circuit.

Pin 8 detects the voltage level of the logic power supply, using the input terminal of the power supply voltage detection circuit. The voltage level to be detected is preset at 4.2V. When the preset voltage level is detected, the Pin 8 sends a reset signal to reset the main logic circuits.

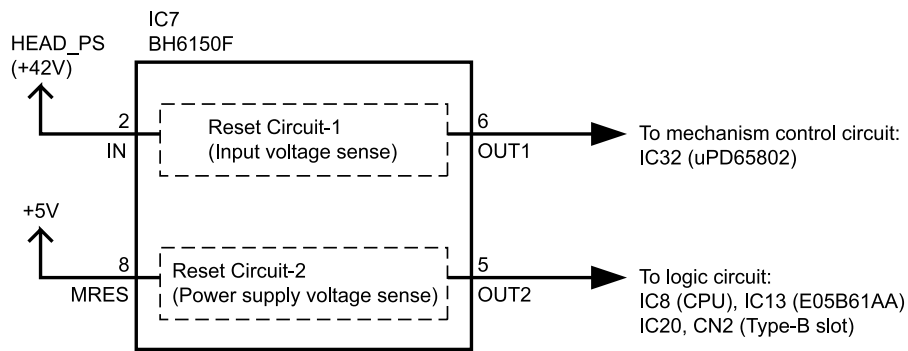

Figure 2-21. Reset Circuit

2.1.2.2 CR/PF Motor Driver Circuit

The EPSON Stylus Pro 9500 uses the DC servomotor to drive the CR and PF motors. Therefore, the encoder is installed to detect the position, direction, and speed of the carriage, and feedback from the encoder enables the software servo control system to control the CR/PF motors.

The signal received from the Pin 60/61 in the IC32 enables the chopping control system to control the output from the motor drive IC, and the output from the Pin 10 in the motor drive IC (IC35/33) feeds back the output current level to the IC32.

The Electro-magnetic Relay (LA1/LA2) is located on the power supply line for the DC/PF motors, and it cuts off the power supply when the front cover is open.

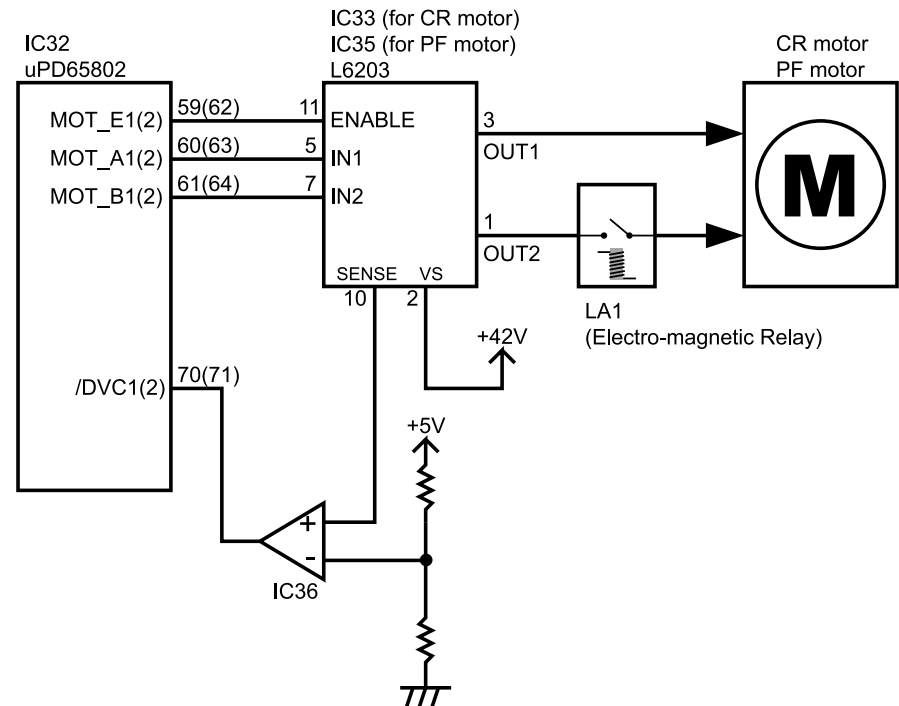

Figure 2-22. CR/PF Motor driver circuit

2.1.2.3 Head SLID Motor Driver Circuit

The Head SLID Motor vertically adjusts the position of the printhead on the carriage according to the thickness of the media in the printer. The motor is driven by the constant current bipolar drive system, and the current supply to the motor is controlled by the PWM current control system. The 4-phase 48-pole PM pulse motor is used for the drive motor, and it is driven by the W1-2 phase excitation.

Based on the preset data received from the IC20, the motor driver IC (IC31) determines the current level to be output to the motor, and the motor is driven by the drive phase switching signal which is input into the Pin 25/18.

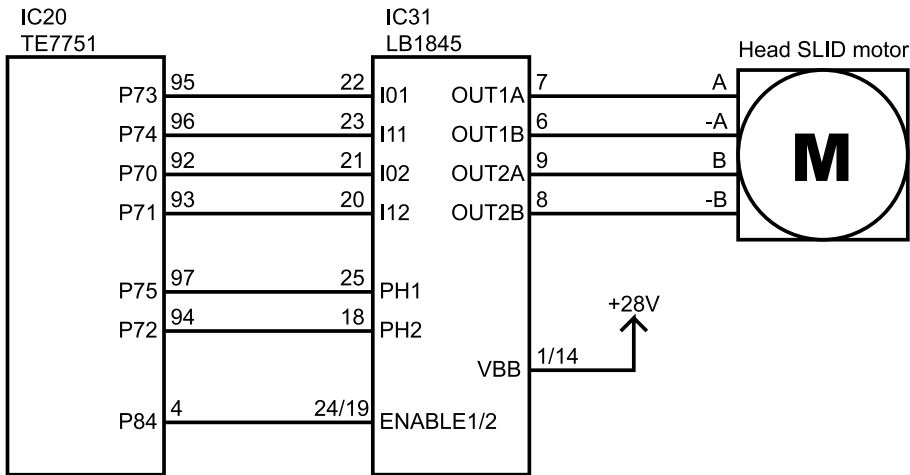

Figure 2-23. HD_SLID Motor driver circuit

2.1.2.4 Pump Motor Driver Circuit

The 4-phase 200-pole HB stepping motor is used to enable the ink system to conduct ink absorption. The basic control method and the circuit configuration are the same as those of the Head SLID Motor Driver Circuit.

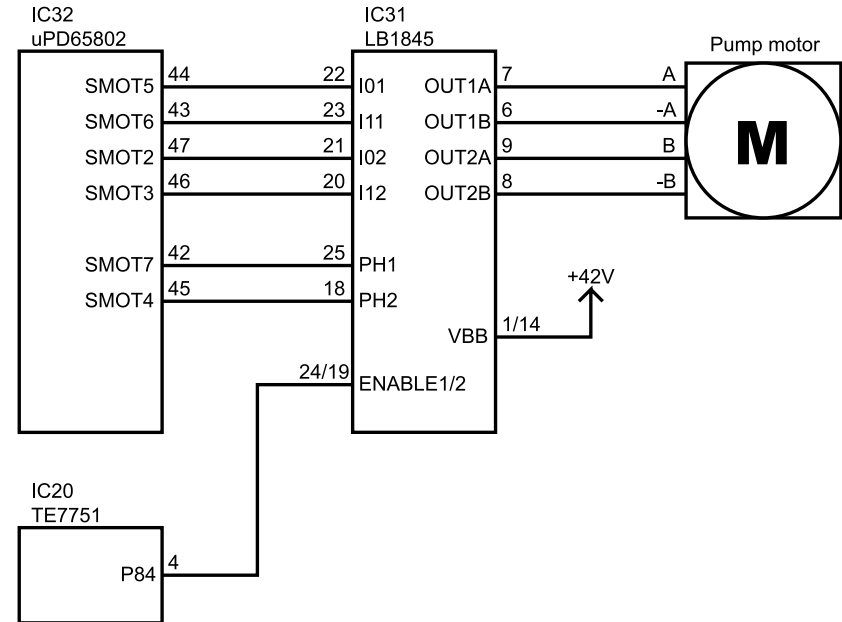

Figure 2-24. Pump Motor driver circuit

2.1.2.5 Printhead Driver Circuit

The EPSON Stylus Pro 9500 uses the same printhead as that of the EPSON Stylus Pro 5000 (both dark-color head and light-color head), and the basic configuration of the driver control circuit is also the same.

Print data is rasterized on the memory (DRAM). Triggered by the LAT signal (BHLAT, CHLAT), the IC13 reads the print data in the format and the order according to the print mode, and transfers the data to the printhead (driver circuit on the printhead) synchronizing with the clock signal (BHCLK, CHCLK). The IC13 is equipped with the counter function, which keeps count of each color's data "1" being transferred to the printhead, and the accumulated count is used to calculate the ink consumption.

The waveform signal is processed at the IC13. Triggered by the input of the PTS signal from the CPU (IC8), the waveform signal is input into the DAC in the IC37 as 10-bit data, synchronizing with the clock signal (20MHz). The DAC then converts the head driver voltage waveform data to analog data, and outputs it to the trapezoid waveform generation circuit (common driver).

The driver circuit on the printhead (nozzle selector) receives the serial data on nozzle selection ("H" level = printing nozzle / "L" level = non-printing nozzle) from the IC13. The circuit then latches the data to the data latch using the LAT signal, and selects the printing nozzles and non-printing nozzles. Once the nozzles are selected, the trapezoid waveform generation circuit (common driver) generates the trapezoid waveform to fire ink. The NCHG signal (BHNCHG, CHNCHG), which is input into the printhead from the IC13, prepares all the nozzles for the next firing by applying slight vibrations during the non-printing phase.

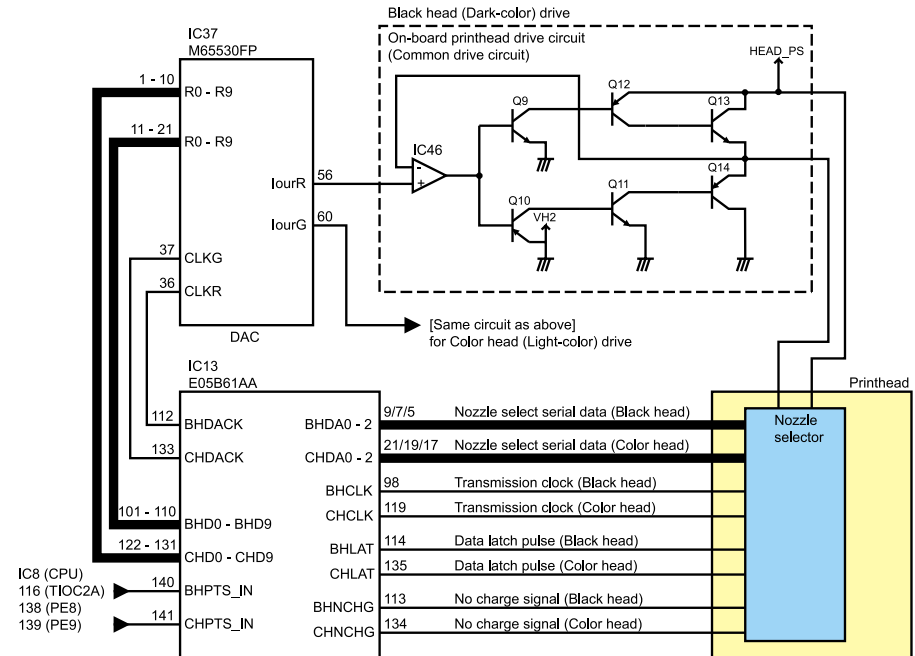

Figure 2-25. Printhead driver circuit

2.1.2.6 Sensors

The output signal sent from each sensor of the EPSON Stylus Pro 9500 is connected to each IC on the control circuit as shown in the diagram on the right.

In order to process the detected results as analog signal, the following sensors input the results into the analog port in the CPU (IC8) via comparator. The analog signal is then converted to the digital signal by the CPU built-in ADC (10-bit) and is compared with the standard value for state analysis.

- P_REAR Sensor
- P_FRONT Sensor
- P_EDGE Sensor

Concerning these sensors, since it is necessary that the reference voltage (threshold) be set at the proper level during AD conversion to match each sensor's characteristics, if the main board is replaced, or if the sensor boy is replaced, it is necessary to adjust the level using the volume (variable resistor) on the circuit board.

Also, the Thermistor inside the print heads detects the head internal temperature, feeds it back to the CPU and carries out drive voltage correction control to match changes in temperature.

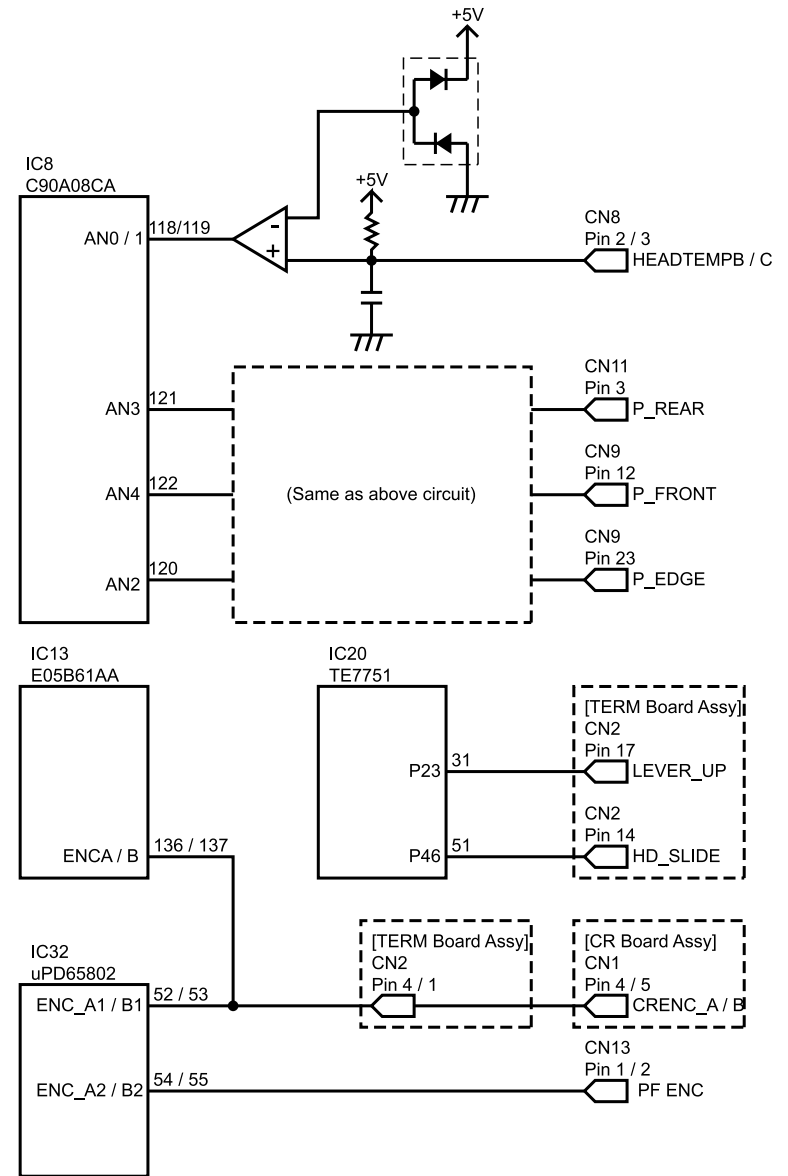

Figure 2-26. Sensors

CHAPTER

3

TROUBLESHOOTING

3.1 Outline

This section describes how to diagnose printer errors as well as how to resolve them. Troubleshooting is divided into the following categories.

- Troubleshooting using the error messages
- Troubleshooting based on printout

In addition to the above troubleshooting points, this section covers check points as well.

3.1.1 Test Points

The following table lists the test points for electrical components.

Table 3-1. Test Points for Electrical Components

Component	Standard
CR Motor	Armature resistance: 10.0 ohm
PF Motor	Armature resistance: 2.3 ohm
SLID Motor	Coil resistance: 17.5 ohm
PUMP Motor	Coil resistance: 3.9 ohm
Cutter Solenoid	Coil resistance: 58 ohm
CR Lock Solenoid	Coil resistance: 58 ohm

3.1.2 Troubleshooting Using the Error Messages

The EPSON Stylus Pro 9500 performs self-diagnostic tests using the data supplied by its various sensors, and if an error is detected by one or more sensors, a corresponding error message appears on the control panel display. No matter what kind of error occurs, use the Error Message List for Service Technicians table on page 70 or the General Error Message List table on page 71 to determine what and where the problem is, as well as where to look for directions on fixing the problem.

- Errors that Require a Service Man

This shows an error state in which it is necessary for a service man to carry out treatment accompanying checking and replacement of the relevant parts.

- General Error

This shows an error state where the user himself can check and carry out the needed treatment.

Table 3-2. Error Message List for Service Technicians

Error	Code	Description	Refer to
MAINTENANCE REQ. nn	0100	Waste Ink pads is almost full (less than 1% remaining)	page 72

Table 3-2. Error Message List for Service Technicians

Error	Code	Description	Refer to
SERVICE REQ. nnnnnnnn	00000100	Waste Ink pads must be replaced Remaining Capacity Zero	page 72
	00000101	Ink Tube worn out	page 72
	00010000	PF motor encoder check error	page 72
	00010001	PF motor out of step	page 72
	00010002	PF motor overcurrent	page 73
	00010003	PF in-position time-out	page 73
	00010004	CR motor encoder check error	page 73
	00010005	CR motor out of step	page 73
	00010006	CR motor overcurrent	page 74
	00010007	CR in-position time-out	page 74
	00010008	Servo interrupt watchdog time-out error	page 74
	00010009	System interrupt watchdog time-out error	page 74
	0001000A	CR origin sensor malfunction	page 74
	0001000C	PG origin sensor malfunction	page 74
	0001000D	Cover sensor malfunction (00)	page 74
	0001000E	Cover sensor malfunction (01)	page 74
	0001000F	CR motor PWM output error	page 75
	00010010	PF motor PWM output error	page 75
	00020000	NVRAM error	page 75
	00020001	Internal RAM check error	page 75
	00020002	SRAM check error	page 75
	00020003	DRAM check error	page 75
	10000004	CPU vector 4 - General illegal instruction	page 75
	10000006	CPU vector 6 - Slot illegal instruction	page 75
	10000009	CPU vector 9 - CPU address error	page 75
	1000000A	CPU vector 10 - DMAC/DTC address error	page 75
	1000000B	CPU vector 11 - Watchdog time-out error	page 75
	10000000"	CPU vector 32~63	page 75

Table 3-3. General Error Message List

Error Type	Message	Refer to
Warning	Ink Low	page 75
ERROR	Paper Out	page 76
	Load xxx Paper	page 76
	Load Paper	page 76
	Paper Jam	page 76
	Cover Open	page 76
	Paper Not Cut	page 77
	Paper Not Straight	page 77
	Reload Paper	page 77
	Push Lever Down	page 78
	Compartment Open	page 78
	Ink Out	page 78
	No Ink Cartridge	page 78
	Remove Paper	page 79
	Option I/F Error	page 79

3.1.2.1 Errors that require a service technician

Here, the contents and treatment methods for each error that requires a service man mentioned on the previous page are explained.

MAINTENANCE REQ. 0100

- Problem
The waste ink pads have absorbed 99% of their potential. The printer can continue printing, but the “Maintenance Req. 0100” message appears instead of the “Ready” or “Printing” messages.
- Solution
Replace the following parts and reset the ink counter
 - Waste Ink Pads (right, left)
 - F Box (right, left)
 - Pump Assembly
 - Cap Assembly
 - Cleaner, Head

SERVICE REQ. 00000100

- Problem
The waste ink pads are completely full, causing a fatal error. The printer stops printing.
- Solution
See the solution for Maintenance Req. 0100.

SERVICE REQ. 00000101

- Problem
A printer part has exceeded its useful life, and to prevent damage to other parts as well as abnormal operations/printouts, an error occurs. This error occurs when the CR Motor has reached 2.5 million passes, and this indicates the Ink Tubes should be replaced due to excessive wear and tear.

- Solution
To make sure the Ink Tube is not worn out, verify no part of the tube shows wear, is loose, or leaks ink anywhere, especially the tube area between the printheads and the ink pipes.

SERVICE REQ. 00010000

- Problem
PF motor encoder check error
The PF motor makes small revolutions clockwise and counter-clockwise. When it turns, the printer checks the rotary encoder output signals to make sure the motor is turning at the correct speed/distance. If there the encoder doesn't send the correct signal or output data, an error occurs.
- Solution
Make sure there is nothing blocking the grid rollers. If that does not solve the problem, check the PF motor encoder connection. If there still is a problem, try the following.
 - Check and adjust the PF Belt tension
 - Replace the PF motor
 - Replace the Main Board

SERVICE REQ. 00010001

- Problem
PF motor out of step - the length of the PF motor internal encoder's pulse is too long or too short compared to the regular pulse. Self-diagnostic Function: Check in “Inspection: Encoder.”
- Solution
Make sure there is nothing blocking the grid rollers. If that does not solve the problem, check the PF motor encoder connection. If there still is a problem, try the following.
 - Check and adjust the PF Belt tension
 - PF Motor encoder sensor mounting position deviation (See Chapter 5.)
 - Replace the PF motor
 - Replace the Main Board

SERVICE REQ. 00010002

- Problem
PF motor overcurrent - Feedback from the PF motor (IC35) driver's 10-pin output (sensor signal) indicates that the PF motor's current is irregular.
- Solution
 - Replace the PF motor
 - Replace the Main Board

SERVICE REQ. 00010003

- Problem
PF in-position time-out - The in-position time is the amount of time the printer waits to make sure the carriage is not moving when the carriage comes to a stop. The rotary encoder is activate for the predetermined "in-position time" and if the encoder sends a pulse, this means the carriage is moving even though it is supposed to be at a full stop, this generates an error.
- Solution
 - Replace the PF motor
 - Replace the Main Board

SERVICE REQ. 00010004

- Problem
CR motor encoder check error
The CR motor makes small revolutions clockwise and counter-clockwise. When it turns, the printer checks the encoder output signals to make sure the motor is turning at the correct speed/distance. If the encoder doesn't send the correct signal or output data, an error occurs.
- Solution
Make sure there is nothing blocking the carriage. If that does not solve the problem, check the CR motor encoder connection. If there still is a problem, try the following.
 - Check the plastic step ruler for soiled areas, obstructions, and damage
 - Replace the encoder sensor
 - Replace the CR motor
 - Replace the Main Board

SERVICE REQ. 00010005

- Problem
CR motor out of step - the length of the CR motor's pulse is too long or too short compared to the regular pulse.
- Solution
Make sure there is nothing blocking the carriage. If that does not solve the problem, check the CR motor encoder connection. If there still is a problem, try the following.
 - Check the plastic step ruler for soiled areas, obstructions, and damage
 - Encoder sensor mounting position deviation (See Chapter 5.)
 - Replace the encoder sensor
 - Replace the CR motor
 - Replace the Main Board

SERVICE REQ. 00010006

- Problem
CR motor overcurrent - Feedback from the CR motor (IC33) driver's 10-pin output (Sense signal) indicates that the PF motor's current is irregular.
- Solution
 - Replace the CR motor
 - Replace the Main Board

SERVICE REQ. 00010007

- Problem
CR in-position time-out - The in-position time is the amount of time the printer waits to make sure the carriage is not moving when the carriage comes to a stop. The linear encoder is activate for the predetermined "in-position time" and if the encoder sends a pulse, this means the carriage is moving even though it is supposed to be at a full stop, this generates an error.
- Solution
 - Replace the CR motor
 - Replace the Main Board

SERVICE REQ. 00010008

- Problem
Servo interrupt watchdog time-out error due to motor-drive control related error
- Solution
 - Replace the Main Board

SERVICE REQ. 00010009

- Problem
System interrupt watchdog time-out error due to sensor-related error
- Solution
 - Replace the Main Board

SERVICE REQ. 0001000A

- Problem
CR origin sensor malfunction - CR home position sensor malfunction
- Solution
Self-diagnostic Function: Check "CR Home Position" in "Inspection: Sensors."
 - Replace the HP sensor
 - Replace the Main Board

SERVICE REQ. 0001000C

- Problem
PG origin sensor malfunction (may indicate PG motor malfunction)
- Solution
Check the sensor surfaces for adhesion of ink or soiling, etc. which might hinder sensor operation. If there is no trouble, and the error cannot be canceled, check the SLID home position sensor (Self-diagnostic function: Check "Head Slide" in "Inspection: Sensors.")
 - Replace the PG sensor
 - Replace the Main Board

SERVICE REQ. 0001000D**SERVICE REQ. 0001000E**

- Problem
Cover sensor malfunction - one or both cover open sensors (interlock switch) located at either end of the cover shaft is malfunctioning.
 - (00): right sensor (HP side)
 - (01): left sensor
- Solution
Make sure the sensor(s) are properly installed. If that does not solve the problem, check the cover open sensor connection. Self-diagnostic Function: Check "Covers" in "Inspection: Sensors."
 - Replace the malfunctioning cover sensor
 - Replace the Main Board

SERVICE REQ. 0001000F

- Problem
CR motor PWM output error
- Solution
 - Replace the Main Board

SERVICE REQ. 00010010

- Problem
PF motor PWM output error
- Solution
 - Replace the Main Board

SERVICE REQ. 00020000 (NVRAM ERROR)
SERVICE REQ. 00020001 (INTERNAL RAM ERROR)
SERVICE REQ. 00020002 (SRAM ERROR)
SERVICE REQ. 00020003 (DRAM ERROR)

- Problem
Unusual condition detected.
- Solution
 - Write down the error code, turn the printer off and back on again to confirm whether the error recurs. If the same error recurs, replace the Main Board.
 - For “Service Req. 00020003” (DRAM error), replace the RAM-SIMM(16MB) installed in CN19 and confirm whether the error recurs.

SERVICE REQ. 10000004 (CPU GNRL ILLEGAL INSTRCTNS)
SERVICE REQ. 10000006 (CPU SLOT ILLEGAL INSTRCTNS)
SERVICE REQ. 10000009 (CPU CPU ADDRESS ERROR)
SERVICE REQ. 1000000A (CPU DMAC/DTC ADDRESS ERROR)
SERVICE REQ. 1000000B (CPU WATCHDOG TIME-OUT ERROR)
SERVICE REQ. 100000## (CPU VECTOR 32~63)

- Solution
 - Write down the error code, turn the printer off and back on again to confirm whether the error recurs. If the same error recurs, replace the Main Board.
 - Send a different print job to make sure the error wasn't due to electrical noise or bad print data.

3.1.3 General Errors

This section describes the errors that can be solved by the user.

INK LOW

- Problem
An ink end sensor has detected that the corresponding ink cartridge is almost empty (ever ink cartridge has an ink level gauge). It is possible to print about 100% duty on B1 size paper with the remaining ink, but the cartridge should be replaced as soon as possible.
If you re-install an ink cartridge that was detected as being in a “Near End” state, the status will immediately go to “Ink Out”. Only install new cartridges.
- Solution
Replace the ink cartridge.



If for any reason you replace an ink cartridge before it reaches the ink-low or ink-out state with a new ink cartridge, you need to reset the ink counter using the control panel and Maintenance Mode 2.

PAPER OUT

- Problem
 - Paper is not loaded.
 - The rear edge of roll paper has been detected.
 - The print job using cut sheets is finished or the rear edge of cut-sheet paper has been detected.
- Solution
 - If paper has run out, remove the printer paper and load new paper. If print data remains in the printer, the data will be printed.
 - If this error occurs even though paper is properly loaded, there may be something on the P-Rear sensor's surface. Clean the sensor's surface (hole in the Paper Guide, Upper) with a clean, dry cloth.

CAUTION

Use a clean, dry cloth when cleaning sensors; never use a wet cloth or soap.

LOAD XXX PAPER

- Problem

The selected paper source (according to the remote PP command) and the paper type selected on the control panel do not match.
- Solution

Load the correct paper or change the panel setting to match the type of paper loaded in the printer.

LOAD PAPER

- Problem

While paper is loaded, the Paper Release lever was pushed up to the Release position.
- Solution
 - Make sure paper is loaded properly and push down the Release lever to lock the paper in place.

- If this error occurs even when the lever is down, in the Lock position, there may be a problem with the Paper Release lever sensor. Check the sensor operation, sensor connection, and board.

PAPER JAM

- Problem

A paper jam occurs when during printing, paper feeding, or paper cutting the carriage is not able to move properly (due to paper catching on some part). The printer determines a paper jam has occurred if the P-Front sensor and P-Rear sensors are in the "on" state but the CR motor is out of step or has overcurrent.
- Solution
 - Check if the appropriate spindle is being used for the paper.
 - Mat synthetic paper roll:
Use of a high tension spindle is recommended.
 - MC image paper roll:
Use of a high tension spindle is recommended.
 - If the paper that is involved in a paper jam is removed, the message "Please start again." will be displayed, so turn the printer's power on again.
 - If the paper jam occurs again after the paper has been removed, check around the carriage mechanism to see if there is some kind of obstruction to carriage movement. If there is some kind of foreign object, etc. present, remove it.

COVER OPEN

- Problem

Front cover is open.
- Solution
 - If the cover is opened during carriage operation or during a cleaning operation, etc., all mechanical operations are halted, so if it is left open for a long period of time, it could have a bad influence on the print head. Therefore, the cover should be closed rapidly.

- If this error occurs when the left and right sides of the front cover are closed securely, the mounting position and operation of the cover open detection sensor (interlock switch) should be checked.



- **If the cover is opened during printing, the affected pass will not be reprinted after recovery, so there will be marks left on the printout at the affected portion.**
- **If you would like to open the cover during printing, press the “Pause” button to interrupt the printing operation, then open the cover. However, even in this case, since the printing times will be different in the area before and after the place where printing was interrupted, irregularities in the print quality (irregular color) will occur.**

PAPER NOT CUT

- Problem
The paper that was supposed to be cut was not cut completely, or the paper was cut but is still in front of the P-Front sensor.
- Solution
 - Remove the cut paper if it is on or near the Front Cover and Lower Paper Guide.
 - Replace the cutter if it is worn out.
 - If miscutting is occurring due to deviation in the paper cutter position, carry out adjustment of the paper guide L installation position, adjustment of the cutter mounting position, checking of the paper cutting position and adjustment of the CR cover height. See Chapter 5.

PAPER NOT STRAIGHT

- Problem
This error occurs when the printer detects the front and rear edges to be skewed (the paper is loaded at an angle/slant) by more than 3mm. If the printer prints on paper that is loaded at a slant, the printer may print outside of the printable area and may fire ink onto the platen. If this happens, the next sheets loaded in the printer may have marred reverse sides.
- Solution
 - Remove the paper loaded in the printer and properly reload it according to the instructions in the user's guide.
 - For roll paper, the edges of the paper may not be lined up; (remove the paper) and carefully squeeze the sides of the roll to make sure the edges are lined up and flat.

RELOAD PAPER

- Problem
This error occurs when,
 - A) The front edge is loaded too far and the paper is not in the loading position after it is reverse fed.
 - B) The paper was loaded in such a way that the left and/or right edge is out of the printable area (due to mis-loading or because the paper is too wide).
 - C) After printing has finished, the right or left edge is out of the area where the cutter can cut the paper.
 - D) The loaded paper was longer than the selected paper, and the paper was not fully ejected. (For example, roll paper is loaded in the printer but cut sheet is selected on the control panel.)
 - E) A cutter error occurred after the paper was ejected.

- Solution
 - A)~C) above
Properly reload paper. If the front edge of the paper is not straight and clean, cut the paper.(If the paper is pulled back and set 60 mm or more from the criterion line (hole), it will exceed the permissible amount of backfeed (200 mm from the paper edge detection sensor position and result in an error.)
 - D)~E) above
Cut of the section of the paper that has ejected/protruded and reload the rest of the paper. For paper that is automatically cut, lift up the Release Lever (the “Load Paper” message appears), fix the position of the paper, and lower the Release Lever. If you select you “Roll Paper/ Auto Cut” setting, you can cut off the protruding part of the paper using the Cut button.
 - If the error recurs even after reloading the paper, make sure the paper-end sensor on top of the carriage is installed correctly and working properly.

PUSH LEVER DOWN

- Problem
The printer is not able to continue paper feeding/initializing, printing, or ink sequencing because the Release lever was moved to the Release position. Or, the printer cannot begin printing because the lever is in the release position.
- Solution
 - Push down the lever. However, if printing was interrupted because the lever was pushed to the release position and the paper shifted, the print job may be marred.
 - If the lever is down and this error still occurs, check the Release-Lever position sensor.

COMPARTMENT OPEN

- Problem
An Ink Holder (I/H) compartment door is open.
- Solution

- Push the I/H lever down to the lock position.
- If the lever is down and this error still occurs, check the lever position sensor.

INK OUT

- Problem
One or more ink cartridges have run out of ink, a near-end cartridge has been reinstalled, or an unsupported ink cartridge has been installed.
- Solution
 - Replace the empty ink cartridge.

CAUTION

When replacing an empty ink cartridge, always replace it with a new ink cartridge; otherwise the printer cannot determine how much ink remains.

- Make sure the ink cartridge is the proper type of cartridge for the printer and the proper color for that slot.
- If the proper cartridge is installed and this error still occurs, check the Ink-End sensor and the Ink ID sensor.

NO INK CARTRIDGE

- Problem
An ink cartridge is not installed or is not installed properly.
- Solution
 - Install the proper ink cartridge in the empty slot.

CAUTION

When replacing an empty ink cartridge, always replace it with a new ink cartridge; otherwise the printer cannot determine how much ink remains.

- If the proper cartridge is installed and this error still occurs, check the Ink-Cartridge sensor.

REMOVE PAPER

- Problem

Printer cannot perform cleaning because of thick paper. (The printheads are too far away from the Cap Assembly.) This error occurs under the following conditions.

 - Thick paper is loaded when the periodic/timer cleaning operation is supposed to begin.
 - The printer attempts to print on thick paper when the periodic/timer cleaning operation is supposed to begin.
 - You turn on the printer and the thick paper is loaded.
 - You attempt to perform a manual cleaning operation when thick paper is loaded.
- Solution
 - Remove thick paper and push the Release lever down. (This causes the cleaning to operation to start and “Wait” appears on the display.) After the cleaning operation is finished, “Paper Out” appears. Load thick paper.

OPTION I/F ERROR

- Problem

An unsupported Type-B interface card is installed.
- Solution

Turn off the printer, remove the unsupported card, and install a supported card.

3.1.4 Troubleshooting Based on Your Printout

This section describes the conceivable print quality problems that may occur with this printer and the troubleshooting points for those errors.

Table 3-4. Print Quality Problems

Description	Refer to
Dot missing	page 79
Uneven printing/poor resolution	page 80
Smudged or marred printout on front side	page 80
Smudged or marred printout on reverse side	page 81
White/black banding	page 81

DOT MISSING

When the printer is not used for a long period of time, the ink in the nozzles can dry up and clog the nozzles. Clogged nozzles cannot fire ink and cause the dot-missing problem in printed documents. If the printhead nozzles do not clear after attempting multiple cleaning operations, check the following points.

1. If there is no output at all or only some the colors print, check the ink valves on either side of the printer I/H Assemblies to make sure the knobs are set to “Open”. (Also, see the user’s guide or printer software.)
2. Perform ink charging again

Select the “Cleaning” function on the control panel’s Self-Diagnostic menu. This sends a lot of ink into the heads and forces out the old ink that is clogging the nozzles.

CAUTION

Do not charge ink too often as this operation consumes a lot of ink. Each head consumes about 94.43ml per operation.

3. If the extra ink charge does not clear the clogged nozzles, confirm the following.
 - There is no damage to or foreign materials in rubber of the Cap Assembly
 - The Cap Assembly valve is operating normally (if it is not, the Cap Assembly will not properly absorb ink)
 - The Cap Assembly retention spring is working properly.
 - The Cap Assembly retention ink tube is working properly.
 - The ink tubes and pipes between the ink cartridges and printheads are properly connected and are not damaged (check the nuts for tightness, the O-rings for warping, and the tubes/pipes for ink leakage)
4. If after following the above steps the printout still shows missing dots, replace one of the parts listed below and check the print out.
 - Main Board
 - Printhead(s)

CAUTION

- **Before you uninstall the Main Board or a printhead, make sure all cables are disconnected. After installing the new board or head, make sure all cables are properly connected; if cable connectors not completely inserted, they can damage circuits or the heads when current is turned on.**
- **Make sure you replace the correct head, B head or C head.**

UNEVEN PRINTING/POOR RESOLUTION

If printout quality suffers from unevenness, poor quality, or similar problems, check the following.

1. Perform platen gap adjustment
Using the control-panel setting or the diagnostic-program function, check the platen gap (bi-directional printing position as well as PG adjustment).
2. If this error occurs only when the user prints on custom or thick paper, (Use the control panel paper thickness setting to correct the paper size and the print position (depending on the paper-thickness setting, the location where the ink strikes the paper may change))
3. If after following the above steps the printout quality has not improved, verify the following.
 - Head angle adjustment
 - Head height adjustment

CHECK POINT

When using the “Adj.B (or C) Head Skew” as well as the “Adj:PG Check Height” functions, always perform the Gap Adjustment or Bi-directional Position Adjustment operation.

SMUDGED OR MARRED PRINTOUT (FRONT)

The front, or top, side of the paper can become smudged or marred if it rubs against the printhead surface. If this happens, verify the following.

1. If the smudged area is just around the front or rear edge of roll paper, make sure the margins (top and bottom) are set to 15mm on the control panel.
(When printing high-duty print jobs with the top and bottom margins set to 3mm, the high volume of ink can cause the paper to warp and rub against the printhead surface.)
2. If the trouble occurs again, check the following.
 - Check if the cap assembly or tension spring has come off.

(If this spring comes off, ink will remain inside the cap and ink adhering around the head nozzle surface will end up adhering to the paper.)

SMUDGED OR MARRED PRINTOUT (REVERSE SIDE)

If the back of the paper is becoming soiled with ink, check the following items.

1. Check if ink is adhering to the paper feed path somewhere and if there is any ink, wipe it off.
 - Sub-platen surface
 - Grid roller surface
 - Paper guide L surface
2. If ink is adhering to the above parts, the likely cause might be the following, so check it.
 - Skewing of the paper during printing (at the point when one page is finished).

WHITE OR BLACK BANDING

If white or black banding (lines across the page) appear on your printout, try the following.

1. Cleaning
2. If multiple cleaning cycles don't clear the banding problem, try adjusting the heads as described below.
 - Head slant adjustment (B head/C head)
If all the nozzles in the B head and C head are not perfectly lined up, the raster lines will overlap. The unprinted area between one line and the next line (where a nozzle was supposed to fire but missed) is banding.
 - Head height adjustment (B head/C head)
 - Bi-directional print position adjustment
 - Gap adjustment opening

CHAPTER

4

DISASSEMBLY & ASSEMBLY

4.1 Summary

This section describes the disassembly and assembly methods for the EPSON Stylus Pro 9500. However, full assembly instructions are not given apart from following the disassembly instructions in reverse order, and where special instructions are necessary, check points are provided.

Where "Caution" and "Check Point" notes are given, be sure to confirm these contents BEFORE starting the corresponding procedure. Where adjustment procedures are necessary, "Adjustment Required" notes describe what you need do to. These adjustment procedures are absolutely necessary and are described in detail in Chapter 5, "Adjustment".

4.1.1 Warnings

Before proceeding with any disassembly or assembly work, make absolutely sure of the following.



- **The power switch is located at the top of the control panel, and to prevent shock or damage to the printer, always remove the power cable before disassembly or assembly**
- **For safety reasons, the front cover position, up or down, is automatically detected by the cover-open sensors which are interlock switches. Do not block or modify these sensors.**
- **Because the Main Board provides a Lithium battery for memory backup purposes, you must keep the following in mind when handling the Main Board.**
 - Be careful to avoid damaging the Lithium electrodes due to short circuits.
 - When replacing the battery, make sure the positive/negative sides are installed correctly
 - The battery can become very hot, so be careful when touching it
- **Wear protective goggles to protect your eyes from ink. If ink gets in your eye, flush the eye with fresh water and see a doctor immediately.**
- **Wear a pair of gloves to protect your hands than the sharp edge in the printer mechanism.**
- **If ink gets on your hands, wash them thoroughly with soap and water. If ink gets in your eyes, rinse them immediately with water.**
- **If it is necessary to remove external printer parts while the printer is on to view the internal operations, be very careful around high speed parts such as the carriage fan.**
- **Keep in mind that the steel carriage drive belt and cutter blade can be dangerous.**

CAUTION

- Before servicing or performing maintenance on the printer, make sure you have enough space. If you need to move the printer, be sure the space is you move to is safe.
- Because the printer is much heavier than most printers (about 96Kg for the printer and options), you need to take extra care. If you need to take apart the printer and stand or lift the printer, four people are necessary.
- Ink may leak onto other printer parts or the printer basket when removing printer parts, so it is recommended to put a sheet or cloth under the printer, especially when working on or near ink-related parts.
- When working on the electrical circuit board, be careful concerning static electricity, which can cause damage to the board. If necessary, use an anti-static wrist band or similar grounding device to prevent static electricity buildup.
- When removing/re-inserting the flat-cable (FFC) from/to a connector, make sure to pull/insert the cable straight. Otherwise, internal contact of the connector may be damaged and this causes a short-circuit to destroy the electrical circuitries.
- The cutter blade is very hard and can damage or scratch printer parts, and it can also be chipped or damaged. Be careful when handling or replacing the cutter.

4.1.2 Tools

This section lists the tools necessary to disassemble or assemble the printer.

Table 4-1. Necessary Tools

Tool	Part Code	Notes
(+) Phillips screwdriver	Regular, every-day tools	-
(-) Standard screwdriver	Regular, every-day tools	-
Round-nosed pliers	Regular, every-day tools	-
PF Loop Sale Assy Assembly tool	1051765	Exclusive tool No. #f730
PF Loop Scale Affixing tool	1051767	Exclusive tool No. #731
Tweezers	Regular, every-day tools	-
Hex (Allen key) wrench	Regular, every-day tools	2.5mm/4mm/5mm
Hex Torque Wrench	1059914	Exclusive tool No. #F760

4.1.3 Screw List

The following table lists all the screws used in this printer.

Table 4-2. Screws

Type	Color	Description
CP(W2)M3x6	black	(+) Crosshead Pan, spring washer, washer,M3x6
CP(W2)M4x12	silver	(+) Crosshead Pan, spring washer, washer,M4x12
CP(W2)M4x6	silver	(+) Crosshead Pan, spring washer, washer,M4x6
CP(W2)M4x12	black	(+) Crosshead Pan, spring washer, washer,M4x12
CP(W2)M3x8	silver	(+) Crosshead Pan, spring washer, washer,M3x8
CP(W2)M4x8	silver	(+) Crosshead Pan, spring washer, washer,M4x8
CP(W2)M3x6	silver	(+) Crosshead Pan, spring washer, washer,M3x6
CP(W2)M4x5	silver	(+) Crosshead Pan, spring washer, washer,4x5
CBF3x6	silver	(+) Bind screw, flange,3x6

Table 4-2. Screws

Type	Color	Description
CPM2x4	silver	(+) Crosshead Pan,2x4
CBM3x6	silver	(+) Bind screw,3x6
Hex screw	silver	six-sided hex screw, 2.5mm

4.2 Disassembly Flow

Refer to the following flowchart when determining the disassembly flow.

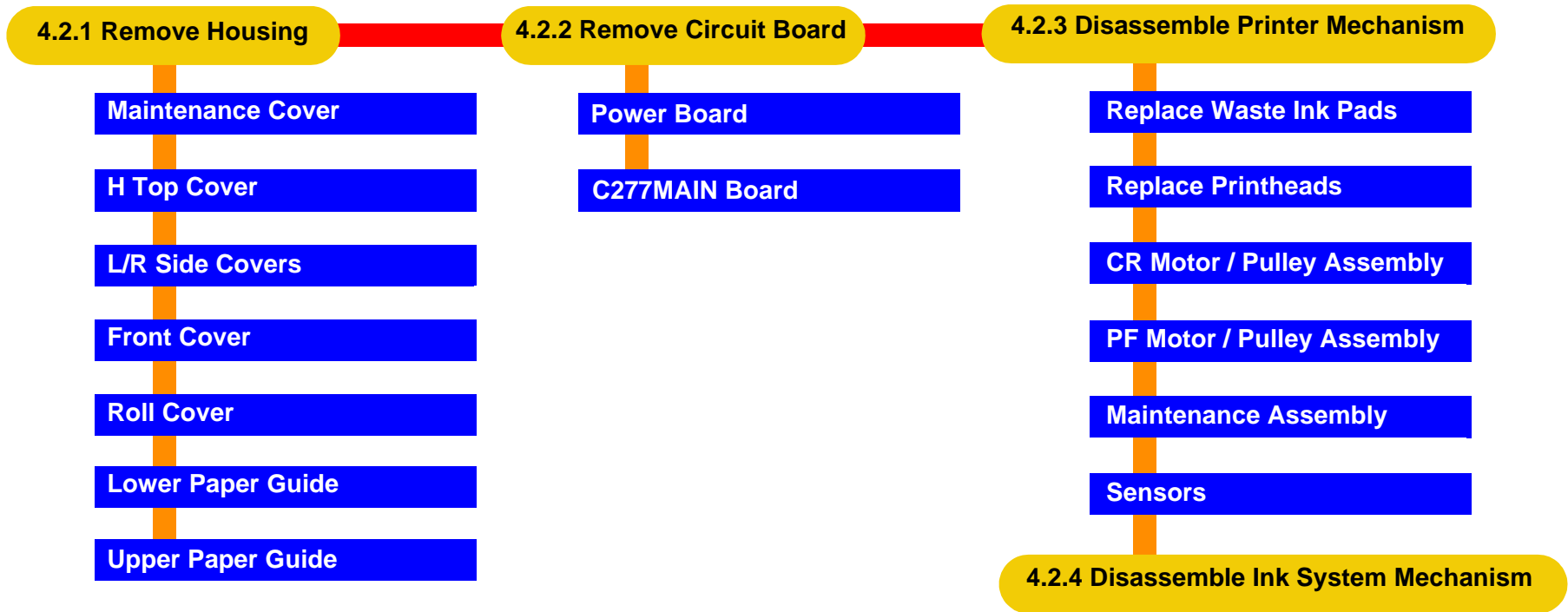

Figure 4-1. Disassembly Process Flowchart

4.2.1 Removing the Housing

This sections describes the removal procedure for printer housing parts. See below for an illustration of the housing parts.

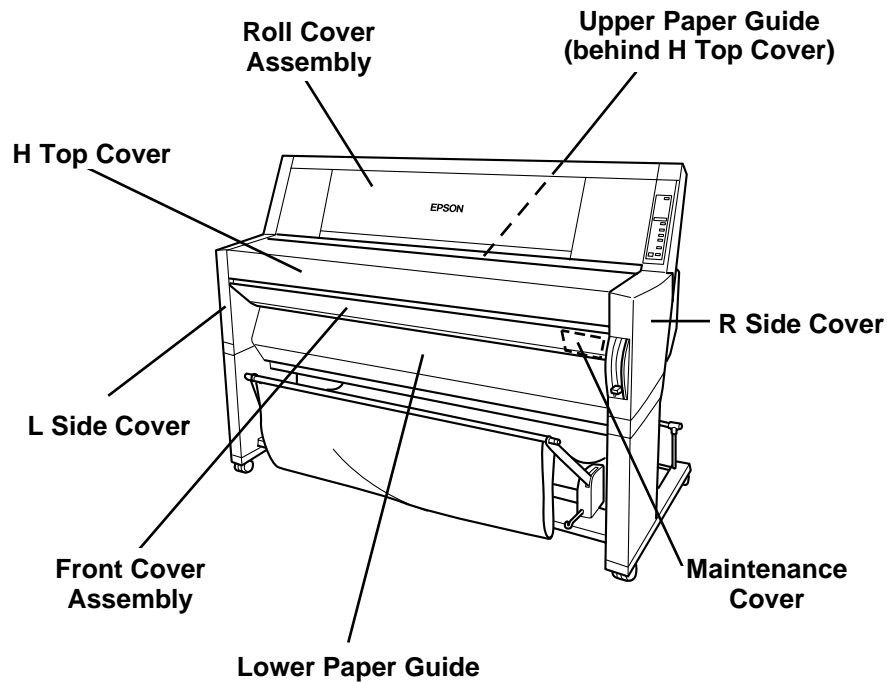

Figure 4-2. Housing Part Diagram

MAINTENANCE COVER REMOVAL

1. Open the Front Cover.
2. Remove 2 screws, CP(W2) M3x6, and then remove the Maintenance Cover.

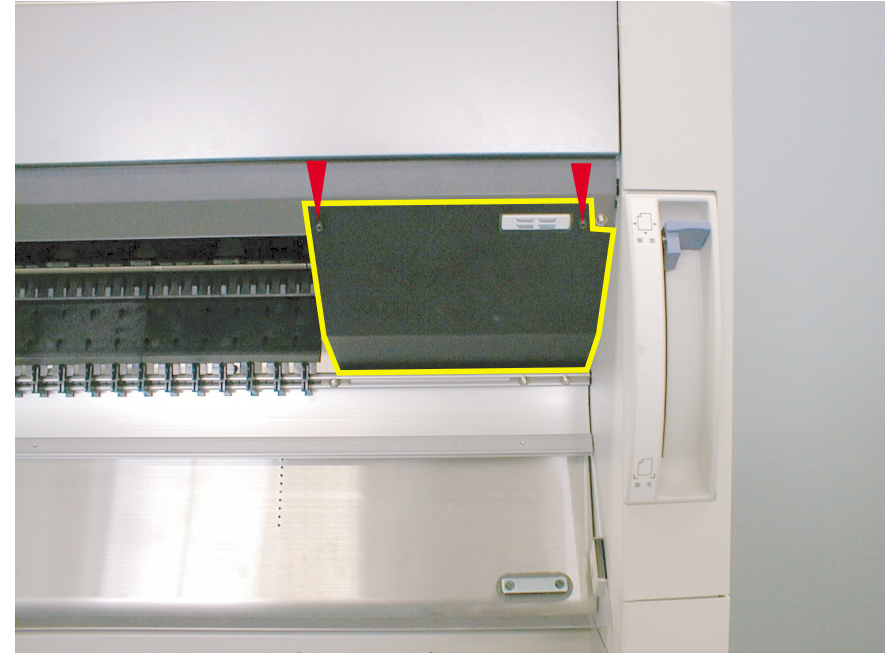



Figure 4-3. Maintenance Cover Removal

H TOP COVER REMOVAL

1. Remove the maintenance cover. (See 4.2.1.1.)
2. Lower the paper release lever.
3. Remove the four screws, CP(W2) M4x12, that secure the left-side lower mounting bracket and remove the bracket. Repeat for the right-side lower mounting bracket.

4. Remove the four screws, two silver CP(W2) M3x6 and two silver CP(W2) M4x6.
5. Lift the H Top cover from the rear edge, and carefully tilt it forward, and lift it away from the printer.

CAUTION  When lifting the H Top Cover off the printer, be careful not to catch the rear edge of the Cover on the P-Thick sensor lever which is in the paper path to the right of center. If the P-Thick sensor is knocked out of position, the printer cannot properly determine the paper thickness.

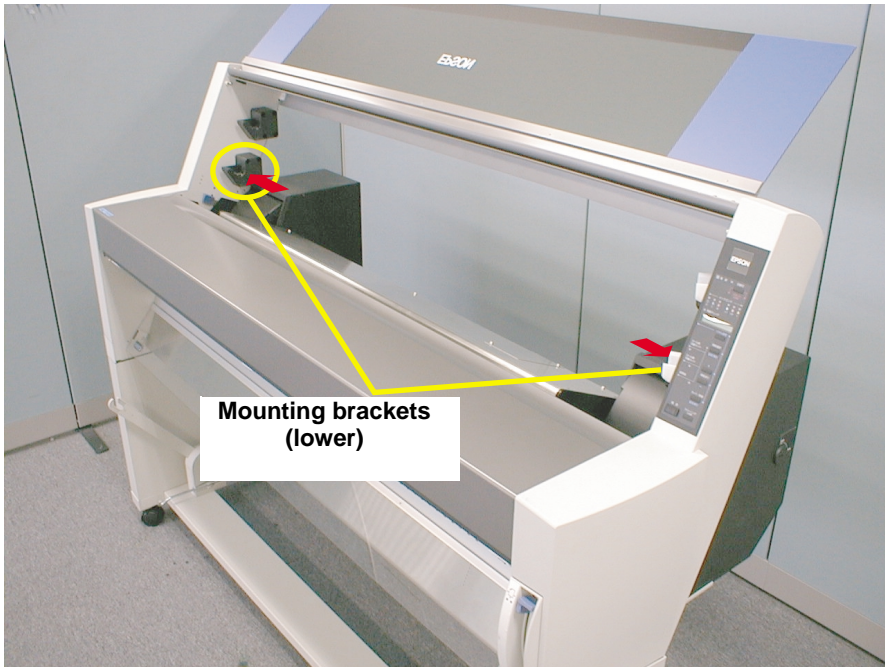

Figure 4-4. Lower Mounting Bracket Removal

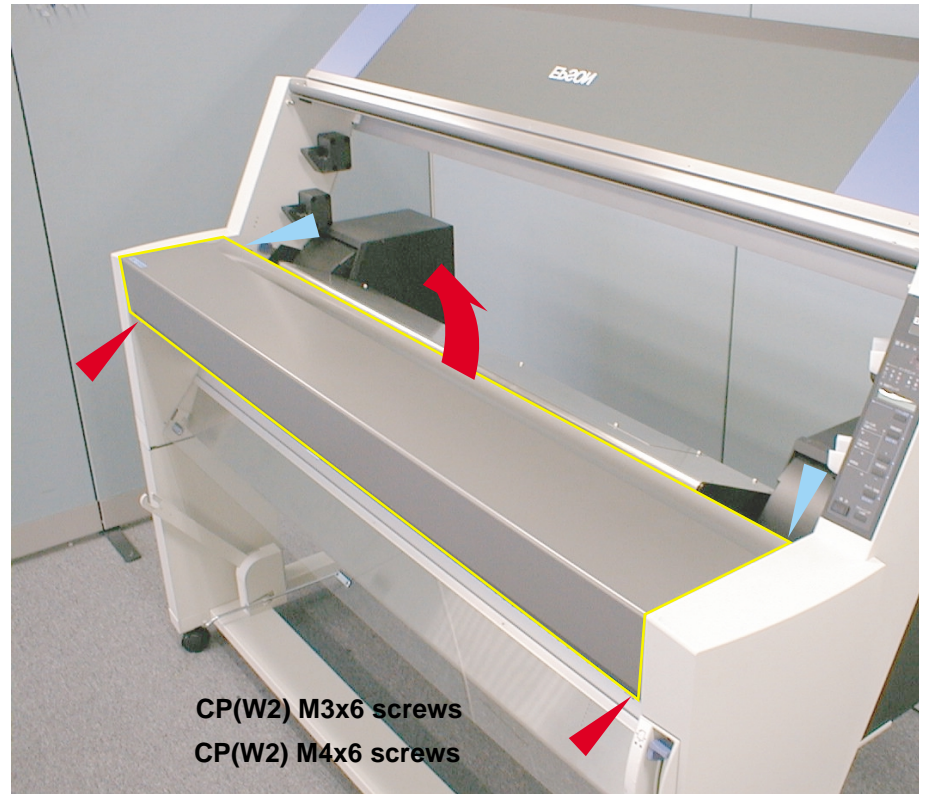
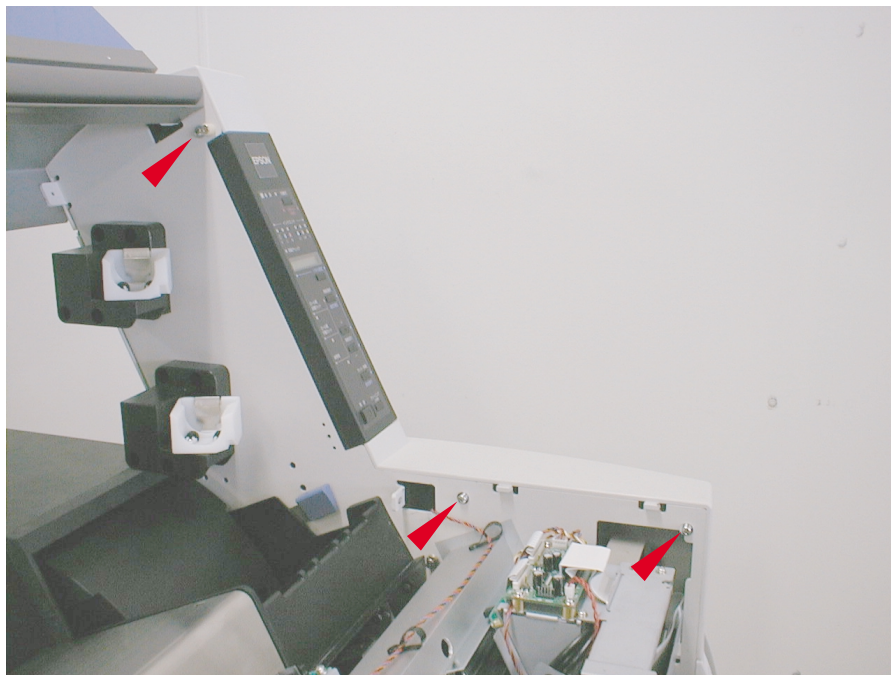

Figure 4-5. H Top Cover Removal

L/R SIDE COVERS REMOVAL

1. Remove the Maintenance Cover. (See 4.2.1.1)
2. Remove the H Top Cover.(See 1.2.1.2)
3. Remove the left and right joint-cover plates (between the stand and printer).
4. Remove the seven screws (five silver CP(W2) M4x12 screws and two black CP(W2) M4x12) securing the Left Side Cover, and remove the Left Side Cover. Repeat for the Right Side Cover plus remove one cable from the back of the control panel.



 CP (W2) M4x12 silver screws

Figure 4-6. L/R Side Cover Screw Location - Inner

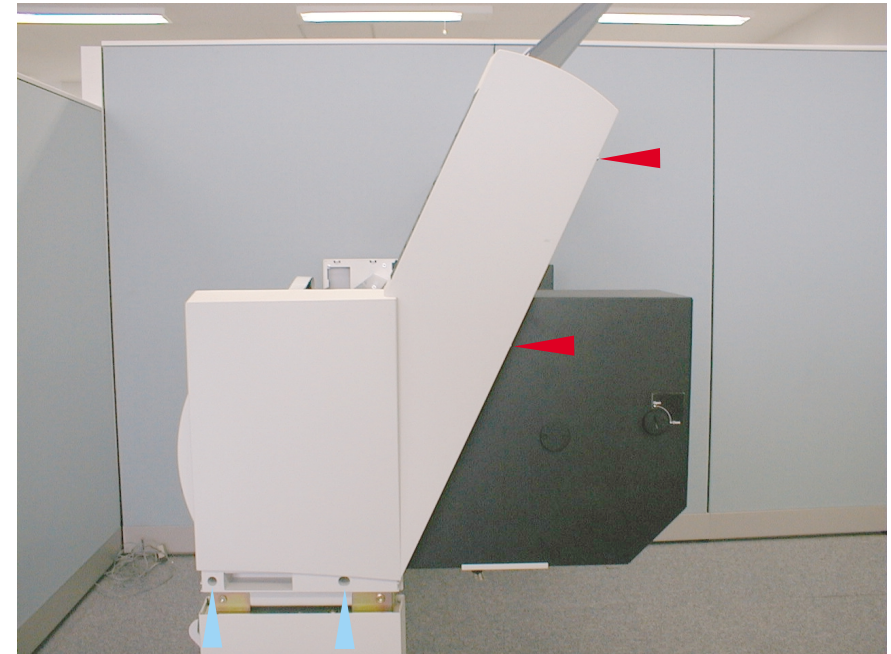

 CP (W2) M4x12 silver screws

 CP (W2) M4x12 black screws

Figure 4-7. L/R Side Cover Screw Location - Outer

FRONT COVER ASSEMBLY REMOVAL

1. Remove the Maintenance Cover.(See 4.2.1.1)
2. Remove the H Top Cover.(See 4.2.1.2)
3. Remove the L/R Side Covers as described in the previous section.
4. Remove the three screws (CP(W2) M3x8) securing the damper assembly on the left side, and then remove the damper assembly.
5. As shown below, the Front Cover Assembly is supported by a shaft and brackets on both sides. The shaft is secured to these brackets with three screws (CP (W2) M3x8), two on the right and one on the left.

Left side

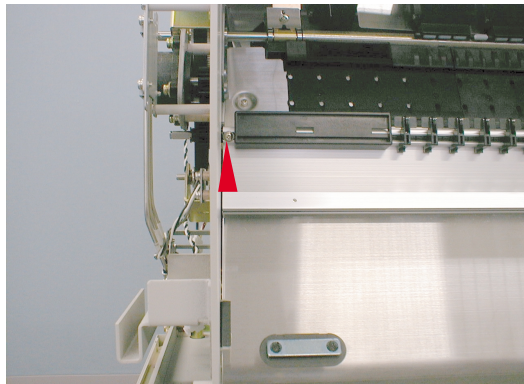

▶ CP(W2) M3x8 screws

Right side

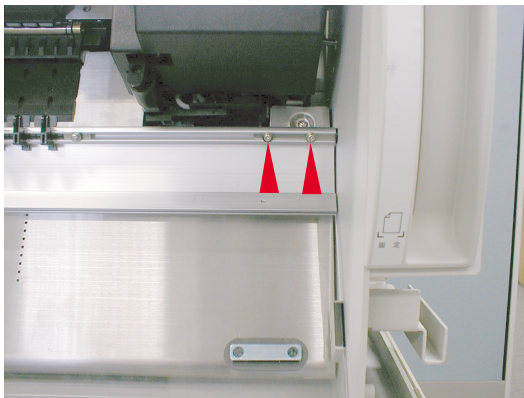

Figure 4-8. Locations of Front Cover shaft screws



The roll assembly parts and guide on the left side of the Front Cover shaft are not fixed and will slide off the shaft if the shaft is tilted down to the left.

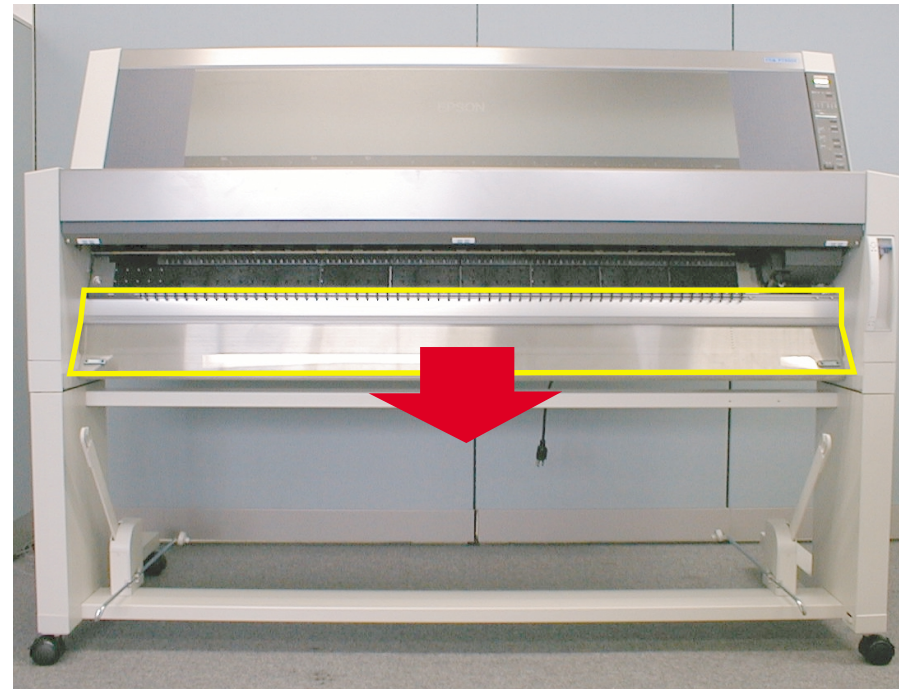
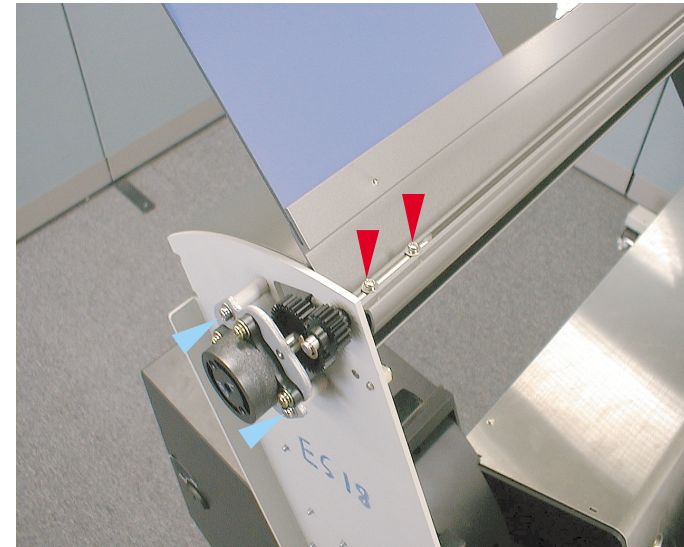

Figure 4-9. Front Cover Removal

ROLL COVER ASSEMBLY REMOVAL

1. Remove the Maintenance Cover.(See 4.2.1.1)
2. Remove the H Top Cover.(See 4.2.1.2)
3. Remove the L/R Side Covers.(See 4.2.1.3)
4. Remove the "Cover Damper L/R Assembly" mounted on the roll cover rotating shaft on the outside of the left and right side frame. (Screws: 2 each / CP(W2) M4 x 8).
5. Remove the four screws (CP(W2) M3x8), two on each side, that secure the Roll Cover Shaft.
6. From the outer sides of the L/R Side Frames, remove the Cover Gear Assemblies, and then remove the Roll Cover Assembly.

Left side of Roll



- ▶ CP(W2) M3x8 screws
- ▶ CP(W2) M4x8 screws

Right side

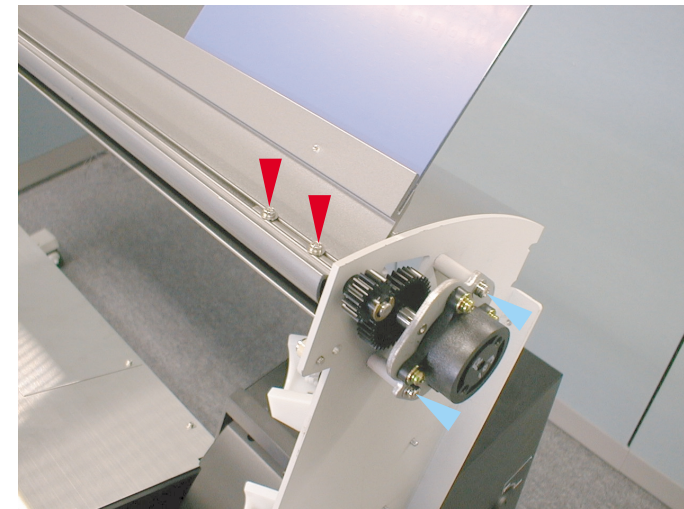

Figure 4-10. Roll Cover Assembly Removal

LOWER PAPER GUIDE REMOVAL



When removing/installing the Lower Paper Guide, the following adjustment procedure is required.

- Adjust the paper guide L installation position. Refer to page 204
- Check the paper cutting position. Refer to page 207
Adjust the cutter mounting position in accordance with the results of the paper cutting position check, then adjust the CR cover height. Refer to page 205,page 143.

1. Remove the Maintenance Cover.(See 4.2.1.1)
2. Open the Front Cover, and remove the eight screws (CP(W2) M3x6) securing the Lower Paper Guide.

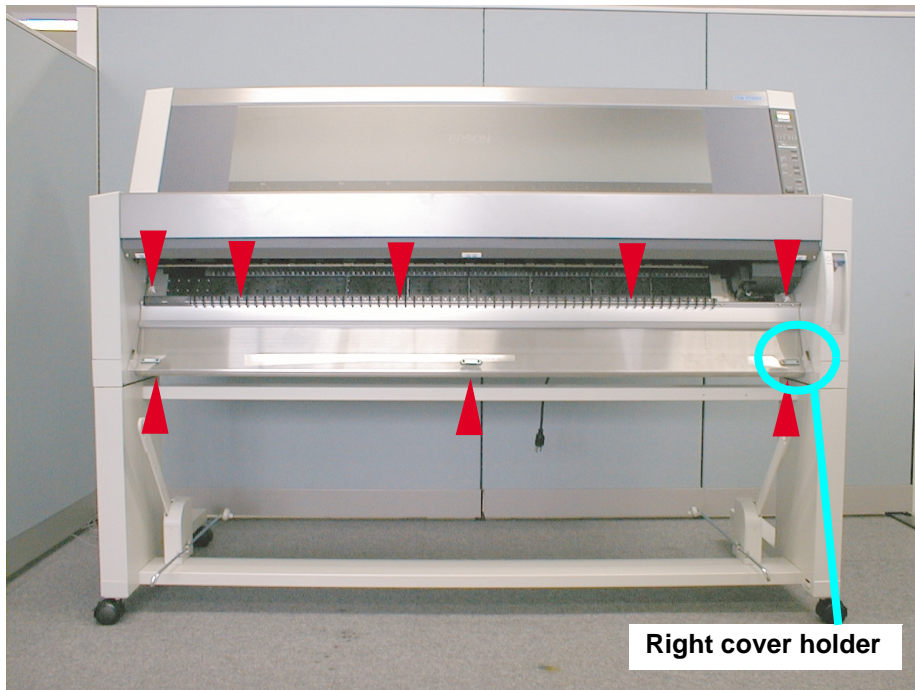

▶ CP(W2) M3x6

Figure 4-11. Location of Lower Paper Guide Screws

3. Remove the screw used to fasten the right cover holder assembly, then remove the right cover holder.
4. While supporting the Front Cover with your hands, lower the Lower Paper Guide as shown below.



- You may find it useful or necessary to move the Front Cover up/down while removing the Lower Paper Guide.
- To avoid interfering with the P-Front sensor, pull the top out towards you as you lower the Lower Paper Guide.

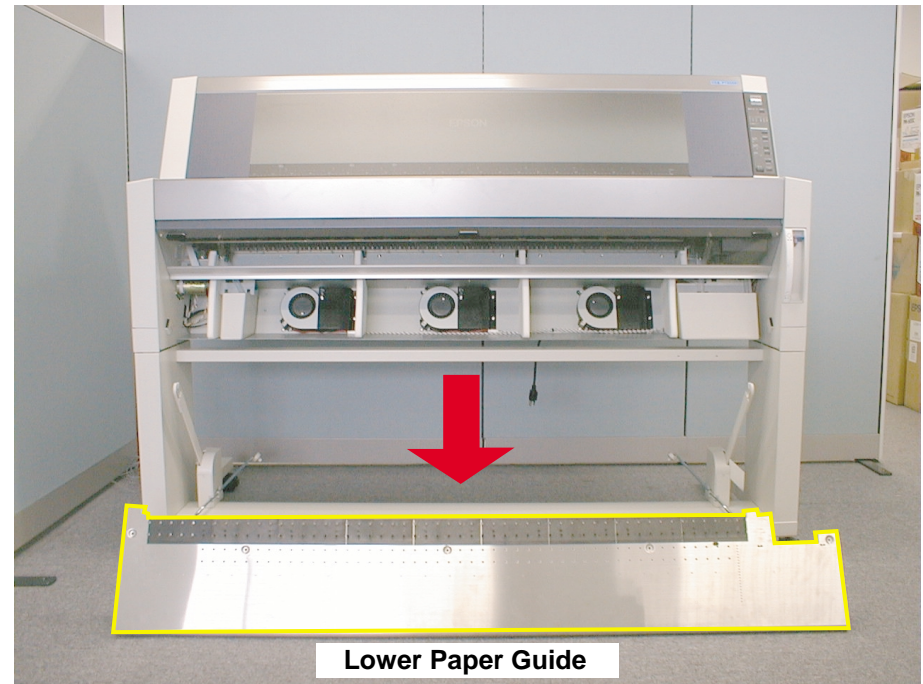
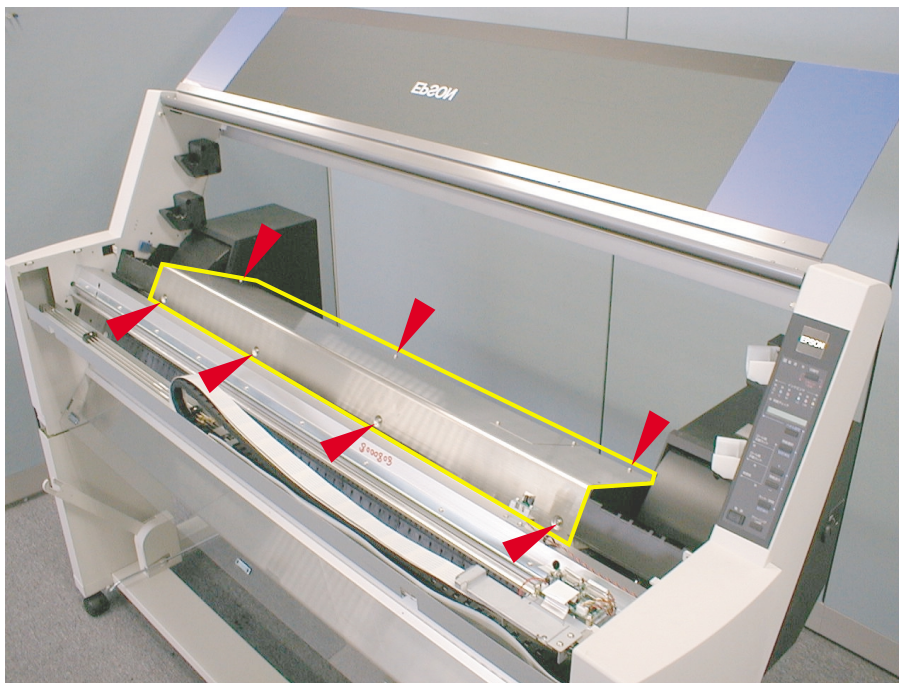

Figure 4-12. Lower Paper Guide Removal

UPPER PAPER GUIDE REMOVAL

1. Remove the Maintenance Cover.(See 4.2.1.1)
2. Remove the H Top Cover.(See 4.2.1.2)
3. Open the Roll Cover.
4. Remove the seven screws (CP(W2) M3x6) that secure the Upper Paper Guide, and then remove the Upper Paper Guide.



▶ CP(W2) M3x6 screws

Figure 4-13. Upper Paper Guide Removal

4.2.2 Circuit Board Removal

This section explains how to remove the Circuit Board (C277PSU) and the Main Board (C277MAIN).

POWER BOARD REMOVAL

1. Remove the H Top Cover as described in "H Top Cover Removal" on page 87.
2. Remove the Upper Paper Guide as described in "Upper Paper Guide Removal" on page 92.
3. Remove the two cables connected to the Power Board as shown below.
4. Remove the one ground screw and five screws that secure the Power Board, and then remove the Power Board.
 - Five CBF M3x6 screws
 - One CP(W2) M4x5 screw

CAUTION



If you are removing the power supply board, the AC cable should be pulled out then it should be left for approximately 5 minutes (in order for the residual charge on the electrolytic condensers to dissipate).

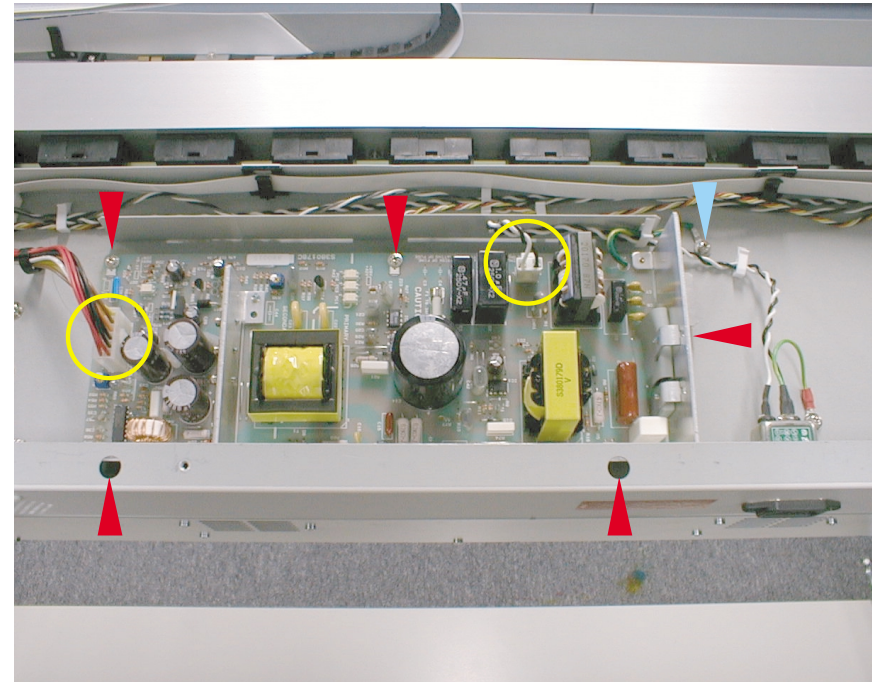

 CBF M3x6 screw

 CP(W2) M4x5 screws

Figure 4-14. Power Board Removal

C277MAIN BOARD REMOVAL

1. Remove the H Top Cover.(See 4.2.1.2)
2. Remove the Upper Paper Guide.(See 4.2.1.7)
3. Remove the cables from the following connectors.
 CN6 CN7 CN8 CN9 CN10 CN11 CN13 CN14
 CN15 CN17 CN18 CN21 CN24 CN26 CN27
4. Remove the two screws securing the Type-B Option Slot Cover, and remove the cover.
5. Remove the twelve screws securing the MAIN Board, and then remove the MAIN board.
 - Board: Nine CBF M3x6 screws
 - I/F connector: Three CP M2x4 screws



When removing/re-inserting the flat-cable (FFC) from/to a connector, make sure to pull/insert the cable straight. Otherwise, internal contact of the connector may be damaged and this causes a short-circuit to destroy the electrical circuitries.



After replacing the main board to new one, various adjustments are required.

- DIP-Switch setting on the Main board (See the next page.)
- Parameter backup (See page 162.)
- Writing the firmware (See page 164.)
- Downloading parameters. (See page 161.)
- Adjusting sensors (page 192.)

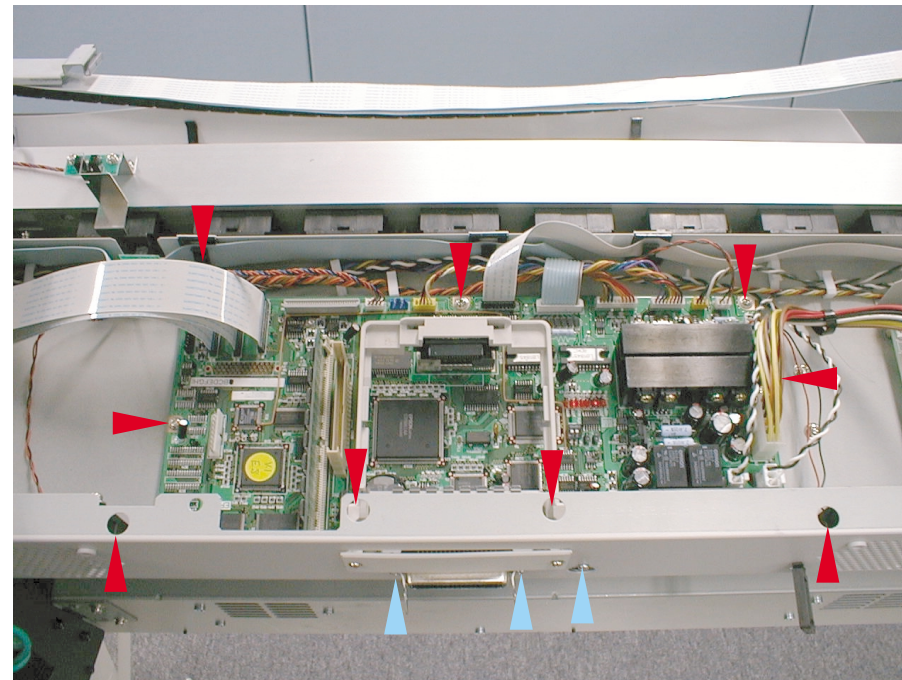

CBF M3x6 screw

CP M2x4

Figure 4-15. C277MAIN Board Removal

CHANGING THE DIP SWITCH SETTINGS ON THE C277MAIN BOARD

The ASP on the C277MAIN board is common with that in the Stylus Pro 9000, but due to the mechanical configuration, the DIP-Switch settings on the MAIN board differ as shown below.

Table 4-3. C277MAIN Board DIP-SW Settings

DIP SW1	DIP SW2	Affected Product	Mechanical Configuration
1	OFF	Stylus Pro 9000	<ul style="list-style-type: none"> PF Roller: 3 roller configuration PF Motor: Built-in encoder
2	ON	No affected product	<ul style="list-style-type: none"> PF Roller: 1 roller configuration PF Motor: Built-in encoder
3	OFF	Stylus Pro 9500	<ul style="list-style-type: none"> PF Roller: 1 roller configuration PF Motor: Encoder is mounted externally.
4	ON	No affected product	Spare Setting

The DIP switch factory setting for the ASP C277MAIN board is setting No. 1 above, so if it is used in the Stylus Pro 9500, the setting should be changed to No. 3 in the table above. The location of the DIP Switch is as shown in the following figure.

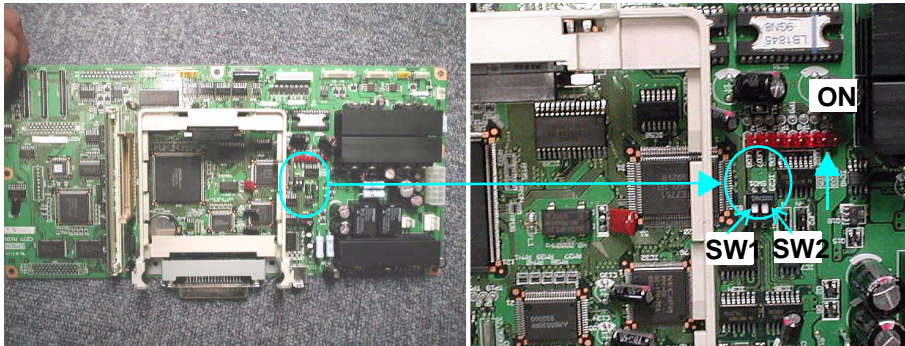

Figure 4-16. C277MAIN DIP Switch Settings

NOTE: Jumpers J1 and J2 should be used with the short setting as is. If the setting is changed, the printer will cease to operate.

4.2.3 Printer Mechanism Disassembly

This section describes the Printer Mechanism components and the procedure for disassembly.

CAUTION



This manual only describes the repair and replacement procedures for parts that can be serviced on site. Therefore, only perform repair or replace procedures that are described here. Other service procedures can only be done at the factory and can become permanent fatal errors if not done correctly.

4.2.3.1 Replacing the Waste Ink Pads

To keep the printhead clean and maintain quality, the printer drains waste ink away from the printhead surface and nozzles into the Waste Ink Boxes. Once a predetermined amount of waste ink has been drained into one of the Waste Ink Boxes, the printer displays the "Maintenance Call 0100" or "Service Call 00000100" to indicate one of the boxes is full and needs to be replaced.

CAUTION



When the printer's useful life counter indicates the ink pads need to be replaced, the following parts all need to be replaced at the same time.

- Waste Ink Pads, Left & Right
- Pump Assembly
- Cap Assembly
- Head Cleaner
- F Box, Left & Right

The above mentioned parts are also available as a Kit.

Description: MAINTENANCE KIT

- Parts code: 1058462

1. Remove the Maintenance Cover.(See 4.2.1.1)
2. Remove the H Top Cover.(See 4.2.1.2)
3. Remove the L/R Side Covers.(See 4.2.1.3)
4. Remove the Front Cover.(See 4.2.1.4)
5. Remove the Lower Paper Guide. (See 4.2.1.6)

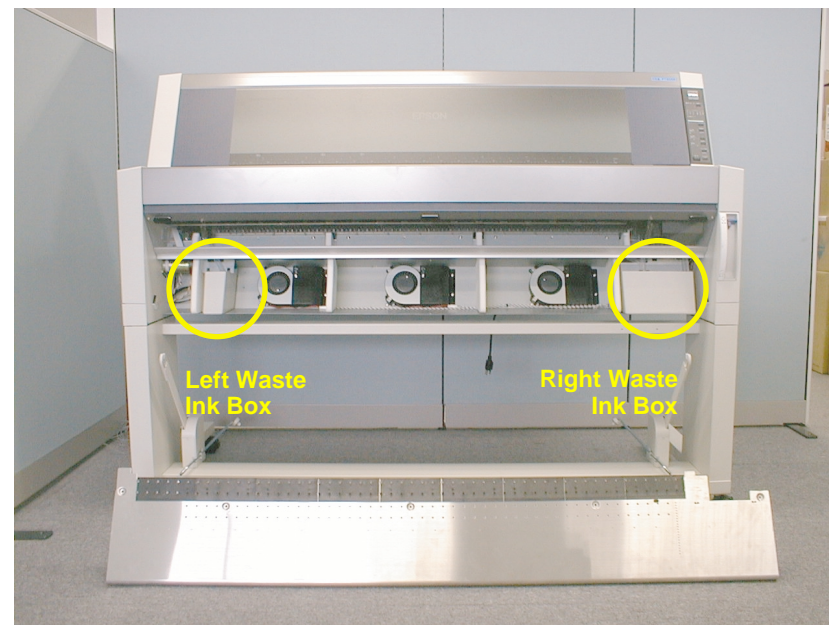
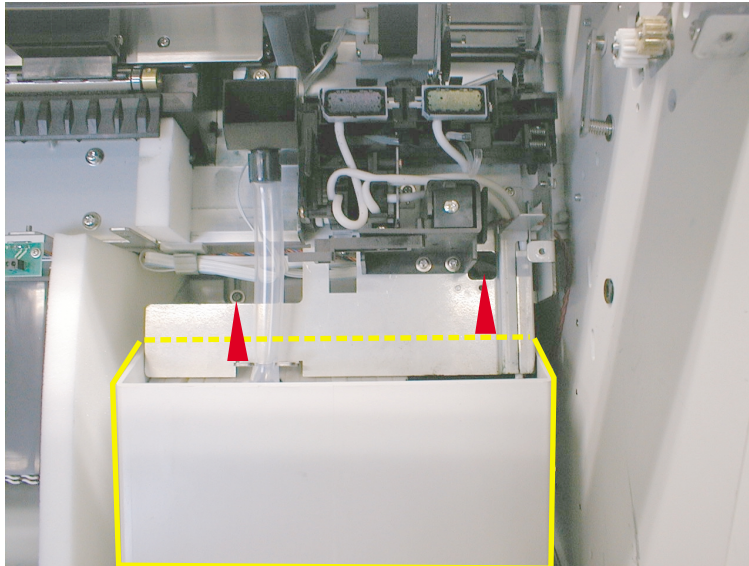

Figure 4-17. L/R Waste Ink Box Positions

6. Remove the following screws that secure the L/R Waste Ink Boxes, and then remove the L/R Waste Ink Boxes.
 - Waste Ink Box L: One CP(W2) M4x8 screw
 - Waste Ink Box R: Two CP(W2) M4x8 screws



▶ CP(W2) M4x8 screws

Figure 4-18. Waste Ink Box R



- When replacing the Waste Ink Pads, prepare a vinyl bag beforehand for disposing the Pads.

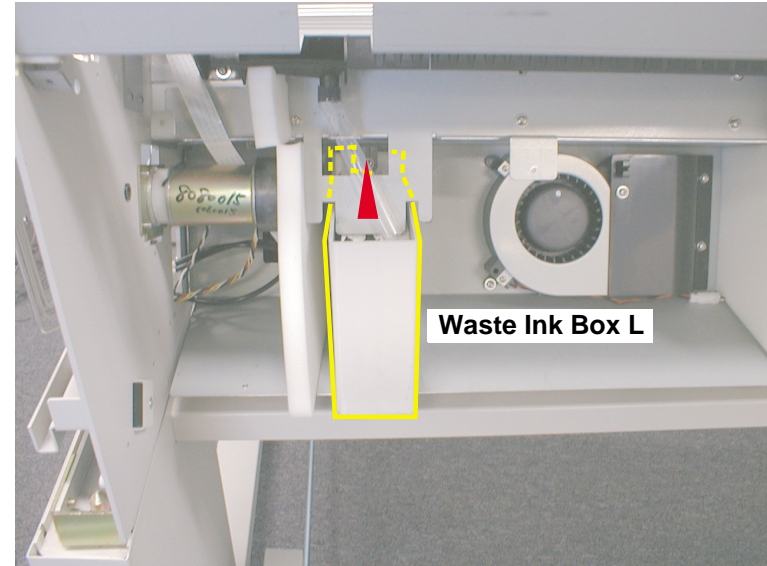

▶ CP(W2) M4x8 screw

Figure 4-19. Waste Ink Box L

7. Remove the old Waste Ink Pads from inside both of the Waste Ink Boxes.
8. Insert new Waste Ink Pads in the Waste Ink Boxes, and re-install the Waste Ink Boxes in the printer.



- When replacing the Waste Ink Pads, following adjustment and setting are required

- Paper Guide L assembling position adjustment. Refer to page 139
- Cutter Position adjustment. Refer to page 205.
- CR Cover Height adjustment. Refer to page 208
- Paper cutting position check. Refer to page 207.
- INIT. WASTE INK (Refer to page 38 or page 200)
- INIT. CLEANER (Refer to page 38 or page 200.)

4.2.3.2 Replacing the Printheads



The printer uses two printheads, B Head and C Head, and although they are similar you need to make sure you do not mix the heads. One is for dark inks and the other is for light inks. Therefore make sure you prepare and install the correct replacement head.

- B head (Dark system head)
F055040: "Printhead, IJ192-OAD"
- C Head (Light system head)
F055050: "Print Head, IJ192-OAE"

Compared to the B head, the above C head is a higher precision head. Therefore, when banding claims occur, it is recommended that this head be used to handle the problem.



When replacing the printheads, the following adjustment procedures are required.

- Self-diagnostic Function / Adjustment (Adjust the inclination of the left and right heads, adjust the right head height, Adjust the Bi-D, Adjust the Gap.) page 167
- Head unit counter reset. Refer to page 200
- Carriage cover height check. Refer to page 208

1. Turn the ink valve knob located on the sides of the I/H Holders to the "Close" position, or lift up the I/C Holder lever. Both operations perform the same function of shutting off the flow of ink through the ink tubes.
2. Open the Front Cover.
3. Remove the Maintenance. (See 4.2.1.1)
4. *Optional:* Remove the H Top Cover. (See 4.2.1.1) This is an extra step during removal and re-installation, but it provides more light and room.
5. Manually release the Carriage Lock and move the carriage away from the capping position.
6. Disconnect the flat cable running from the "CR Board Assembly" mounted on top of the carriage from the affected print head.
7. Remove two screws (CB M3x6), and remove the carriage cover



Figure 4-20. Carriage Lock Release

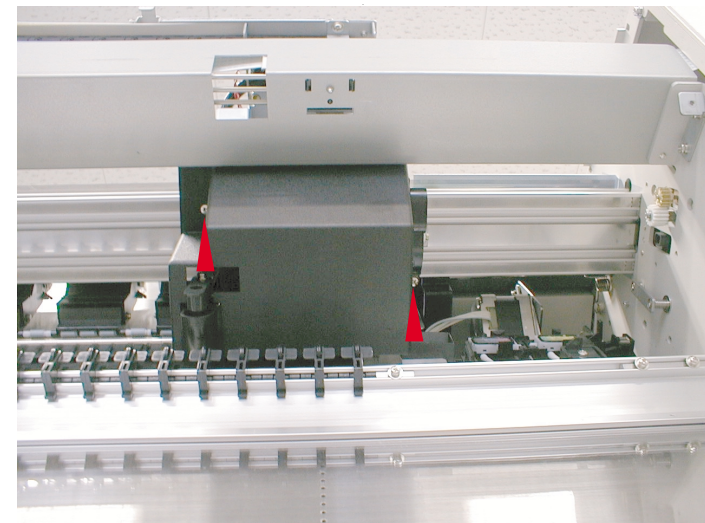

▶ Screw (CB M3x4)

Figure 4-21. Carriage Cover Removal *with H Top removed

8. Remove the 1 screw (CP(W2) M3 x 6) and remove the “Damper Holder.”
9. Take out the damper assembly connected to each print head. At this time, it is easier to remove the damper assembly if a flat blade screwdriver or similar implement is inserted between the damper positioning material and the bottom surface of the damper and is used to pry it up.

CAUTION  If you grasp the side of the damper, the ink that is filling the inside of the damper will leak out, so absolutely do not apply any force to the sides.

10. Using needle nose pliers, etc., remove the compression spring that is fitted in the print head. (9.9)

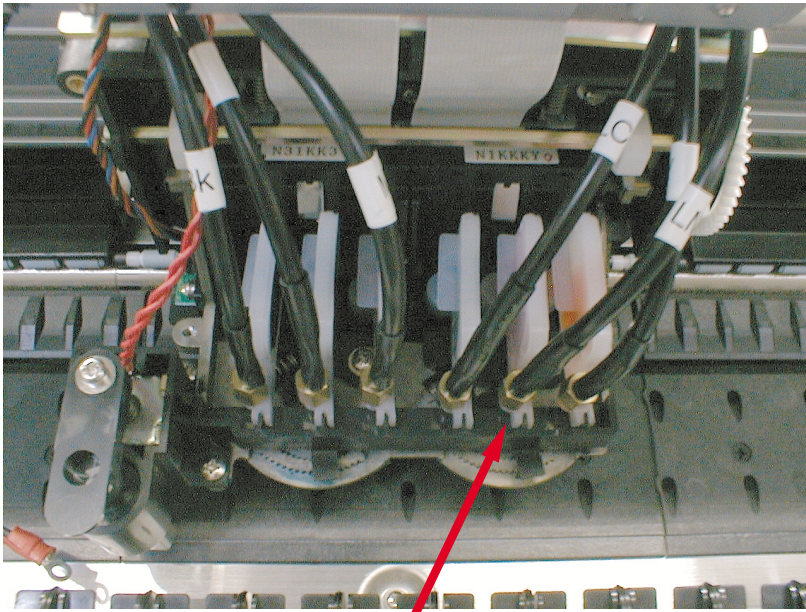

Insert a flat-head screwdriver between the bottom of the damper and the printhead to remove the damper

Figure 4-22. Damper Removal

11. After removing the 1 screw (CB M3 x 6) and the “H spacer,” remove the print head from the carriage briefly.
12. Take out the flat cable that is connected to the back of the print head and remove the print head.

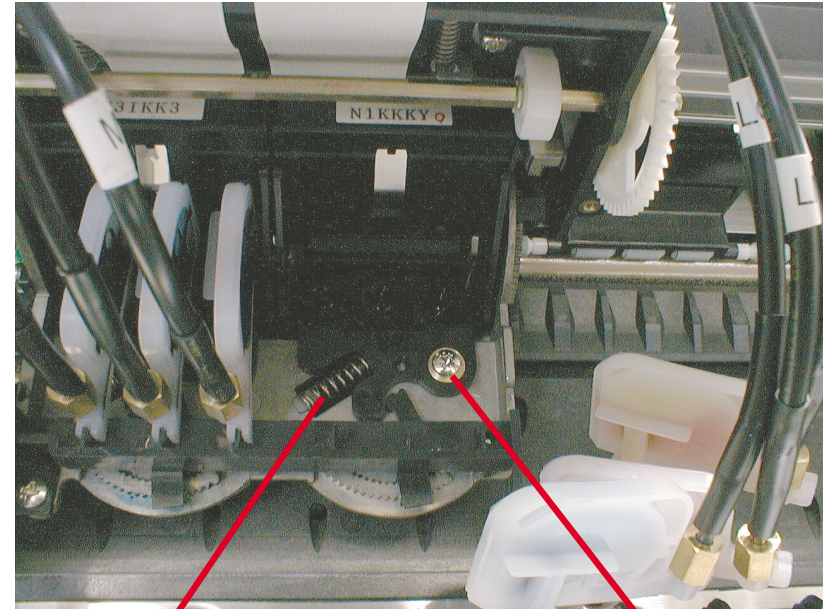

Tension Spring, 9.9

CB M3x6/H Spacer screw

Figure 4-23. Printhead Tension Spring and Screw Removal

CAUTION  When replacing the damper assembly or removing it, or when tightening the hex screws holding the ink tubes and damper, the specified torque wrench (tool No. #f760) should be used. If the tightening torque exceeds the standard, it could damage the O-rings and cause ink to leak and missing of dots.

4.2.3.3 Removing the CR Motor/Pulley Assembly

1. Remove the L/R Side Covers.(See 4.2.1.3)
2. Manually release the Carriage Lock and move the carriage away from the capping position.
3. On the Left Side Frame, find the CR Driven Pulley and loosen the two screws securing it to the frame. Then loosen the tension on the steel belt.

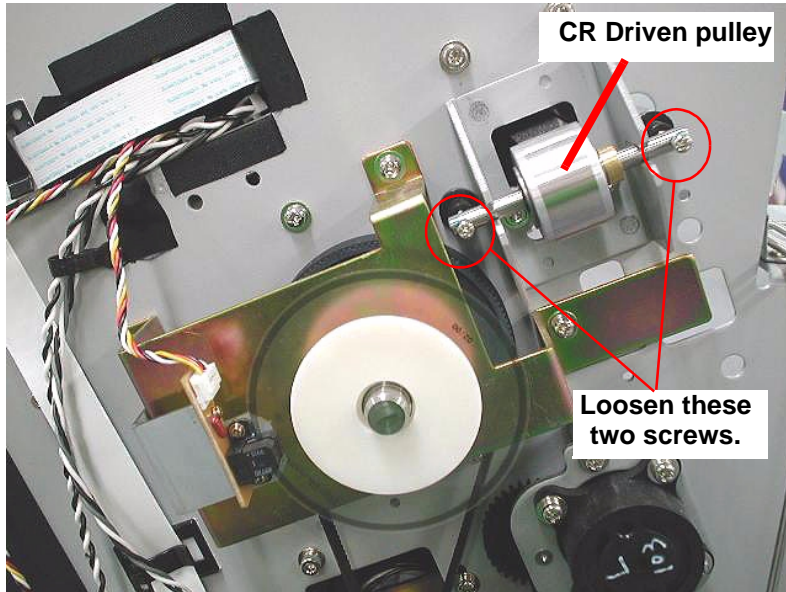

Figure 4-24. CR Motor Removal & CR Steel Belt Loosening



When removing the CR Motor, the following adjustment procedures are required.

- CR Steel Belt Tension Adjustment.Refer to page 213

4. Towards the right side of the frame there is one screw securing the steel belt, remove this screw. Then remove one edge of the steel belt, and finally pull out the steel belt to the Right Side Frame.

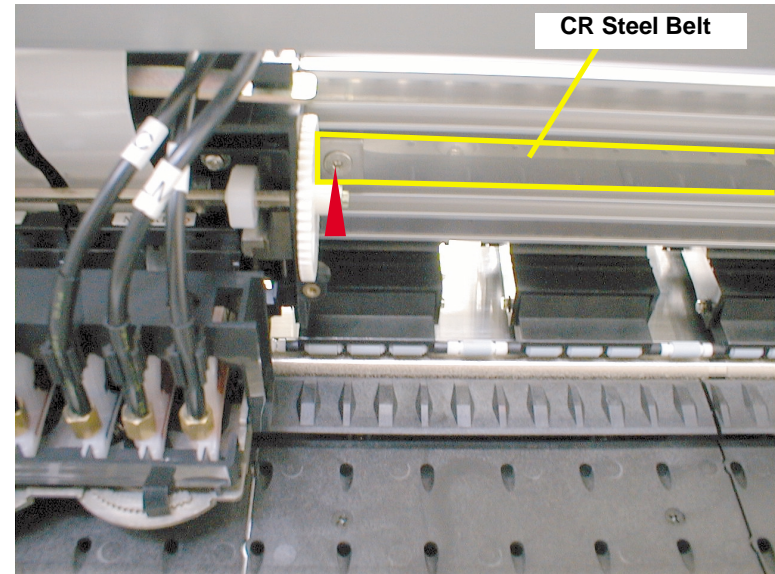

Remove one Hex Screw:2.5mm

Figure 4-25. CR Motor Removal/Steel Belt Removal

5. Loosen the Hex (Allen key) screw (2.5mm), and then remove the bearing stopper attached to end of the CR Motor Shaft.
6. Take out the 4 screws (CP(W2) M4 x 8) holding the CR motor pulley assembly on the mounting bracket on the side of the right side frame, then remove the CR motor pulley assembly.

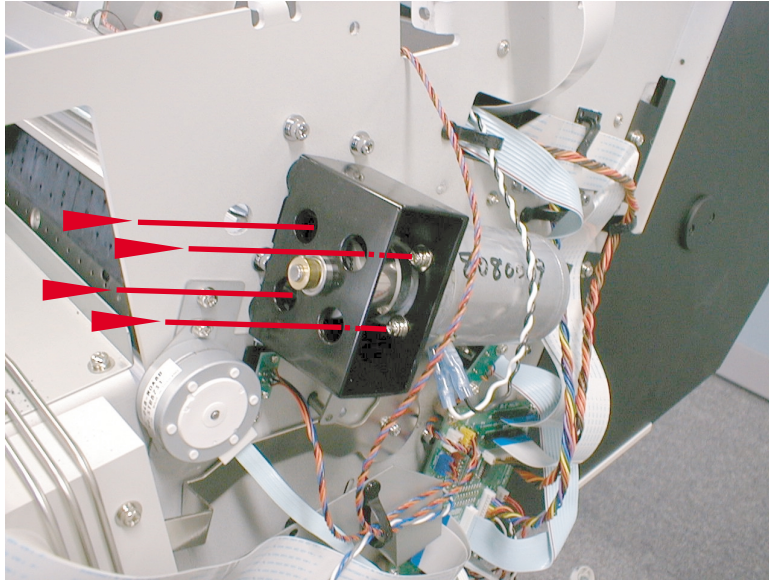

▶ Four CP(W2) M4x8 screws

Figure 4-26. CR Motor Removal



During assembly, when fastening the Y follower pulley assembly, move the carriage to the left and right by hand and set the positioning screw while confirming that the steel belt fits uniformly in the center of the pulley. (Left to right run out of the steel belt on the pulley should be within 1 mm.)

4.2.3.4 Removing the HD_SLID motor assembly

1. Remove the R side cover. (See 4.2.1.3)
2. Disconnect the cable from the connector CN18 on the relay board.
3. Remove the two screws (CP(W2) M3x8) securing the HD_SLID motor assembly to the side frame.

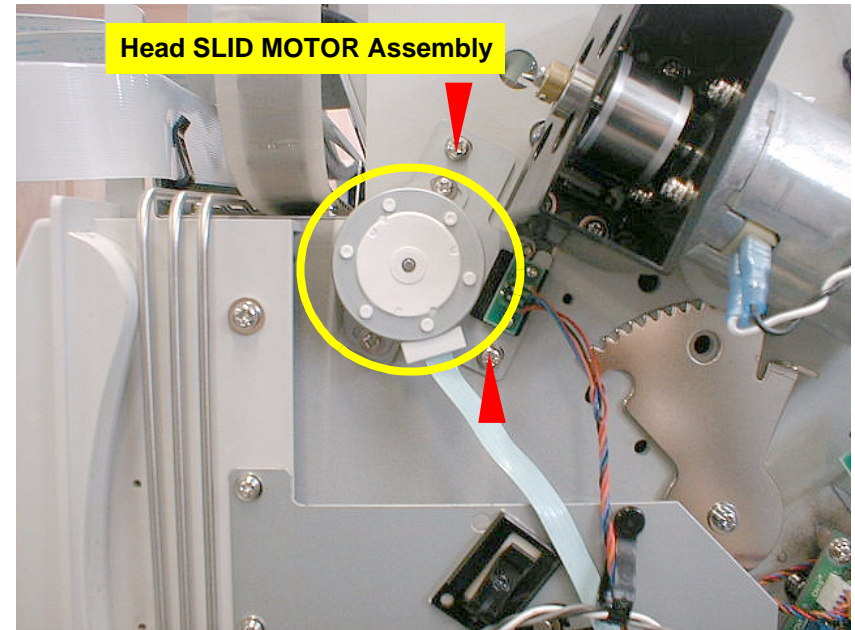

Figure 4-27. HD_SLID Motor Assembly Removal



When removing/installing the HD_SLID Motor assembly, the following adjustment procedure is required.
- Gear backlash adjustment. Refer to page 214.

4.2.3.5 Removing the PF Motor X Deceleration Belt

CAUTION When removing the X deceleration belt, be careful not to get injured by the scale for the PF encoder sensor.

1. Remove the L side cover. (See 4.2.1.3.)
2. Remove paper guide L. (See 4.2.1.6.)
3. Take out the 4 screws (CP(W2) M4 x 8) holding the “Deceleration pulley support” on the side of the left side frame.

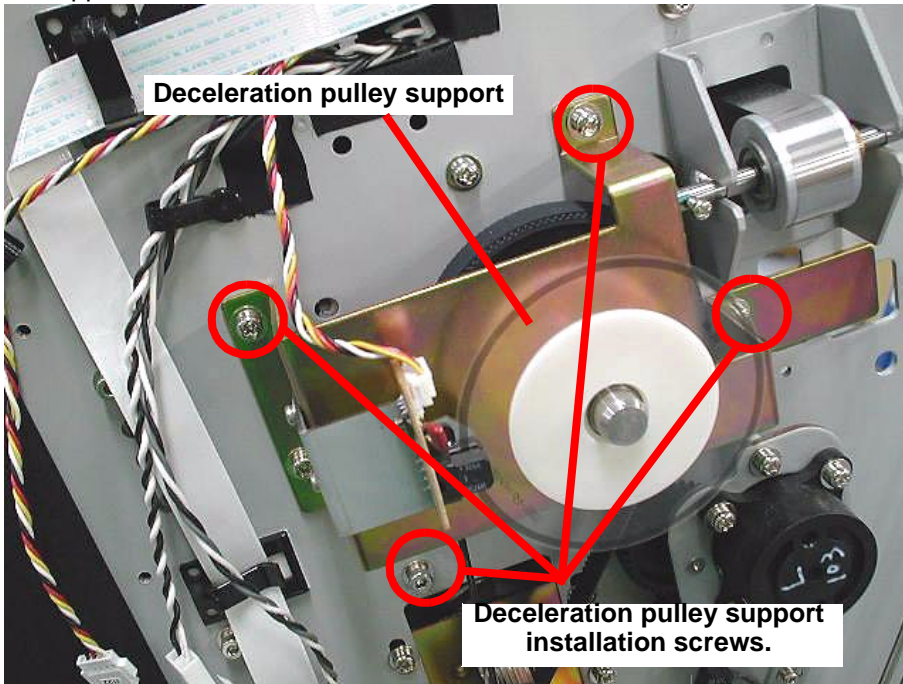

Figure 4-28. Taking Out the Deceleration Pulley Support Installation Screws

4. Take out the 2 screws holding the PF encoder sensor mounting plate.

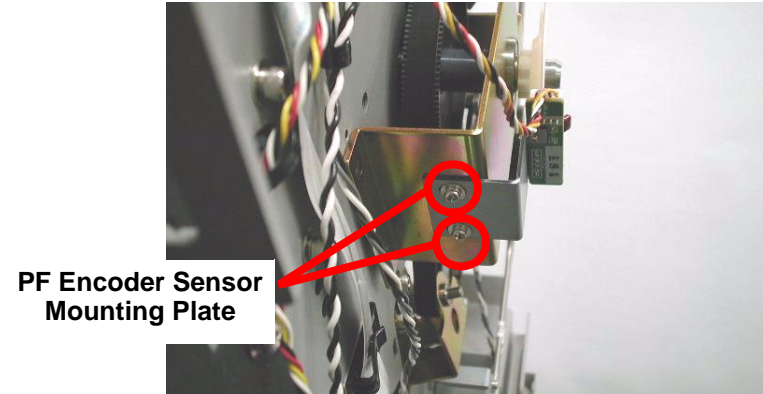

Figure 4-29. Removing the PF Encoder Sensor Mounting Plate

5. Loosen the 4 screws (CP(W2) M4 x 12: blue screws in the figure) holding the “X Motor Mounting Plate”, then release the tension on the X deceleration belt.
6. Take out the 2 screws (CP(W2) M3 x 8: red screws in the figure) holding the PF motor pulley assembly on the “X Motor Mounting Plate,” then remove the PF motor pulley assembly.

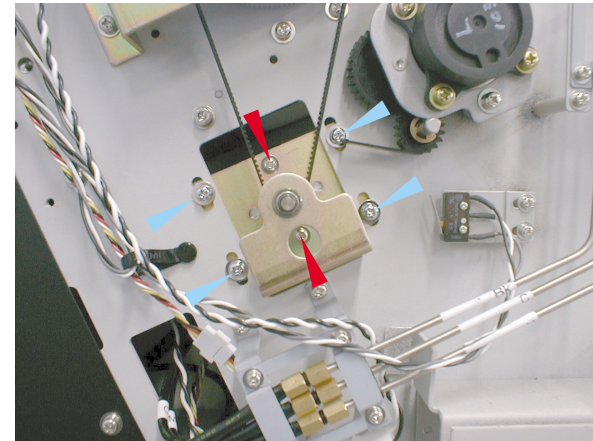

Figure 4-30. Removing the PF Motor Pulley Assembly

7. Take the X deceleration belt off the PF motor pinion gear.
8. Turn the deceleration pulley support clockwise as in the figure below, then remove the X deceleration belt from the printer front arm of the deceleration pulley support toward the outside.

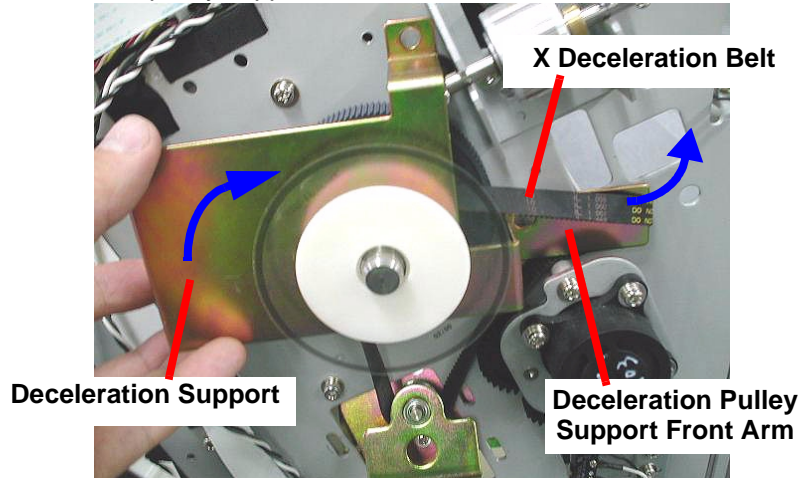

Figure 4-31. Removing the X Deceleration Belt 1

9. Remove the X deceleration belt from the upper arm of the deceleration pulley support toward the outside.

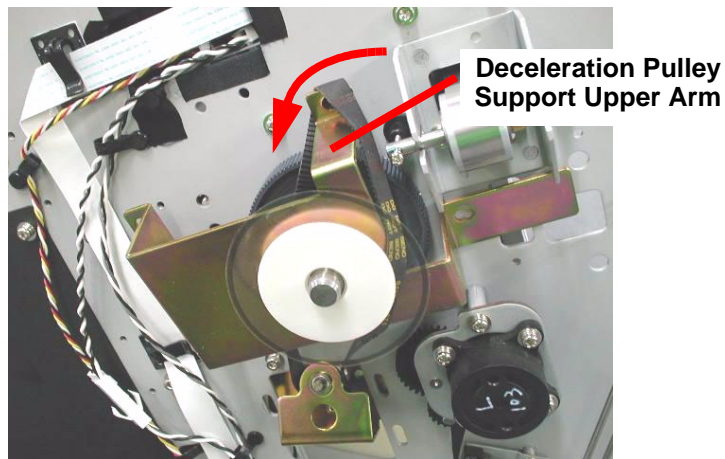

Figure 4-32. Removing the X Deceleration Belt 2

10. Remove the X deceleration belt from the printer rear arm of the deceleration pulley support toward the outside.

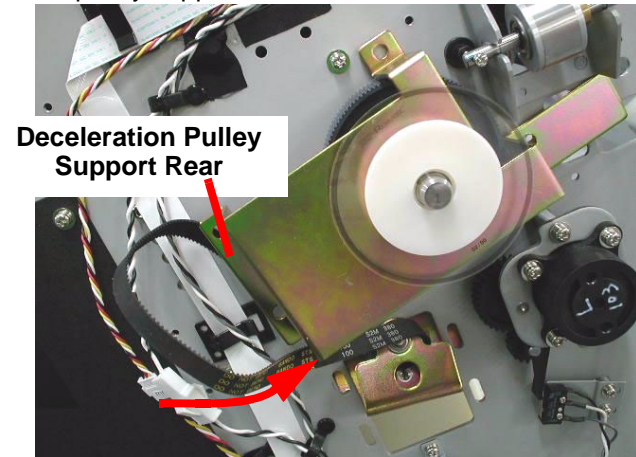

Figure 4-33. Removing the X Deceleration Belt 3



If you are replacing or removing the X deceleration belt, the following adjustment should be made.

- Paper guide L installation position adjustment
Refer to page 204.
- Check the paper cutting position. Depending on the condition, adjust the cutter installation position and adjust the CR cover height. Refer to page 207
- X belt tension adjustment. Refer to page 213
- PF encoder sensor mounting position adjustment
Refer to page 211.
- PF encoder sensor mounting position adjustment 2
Refer to page 211.

4.2.3.6 Cautions when Replacing the PF Loop Scale

□ Procedure for Assembling the PF Loop Scale Assembly

When assembling the PF Loop Scale Assembly, the following exclusive tools should be used.

- Exclusive tool No. #F730: PF Loop Scale Assembly Base (Code: 1051765)

The assembly procedure is shown below.

1. Set the exclusive tool #F730 as shown in the figure below and set the PF loop scale base part with the double sided tape side facing up.
2. Peel off the protective backing material from the double sided tape on the PF loop scale base.

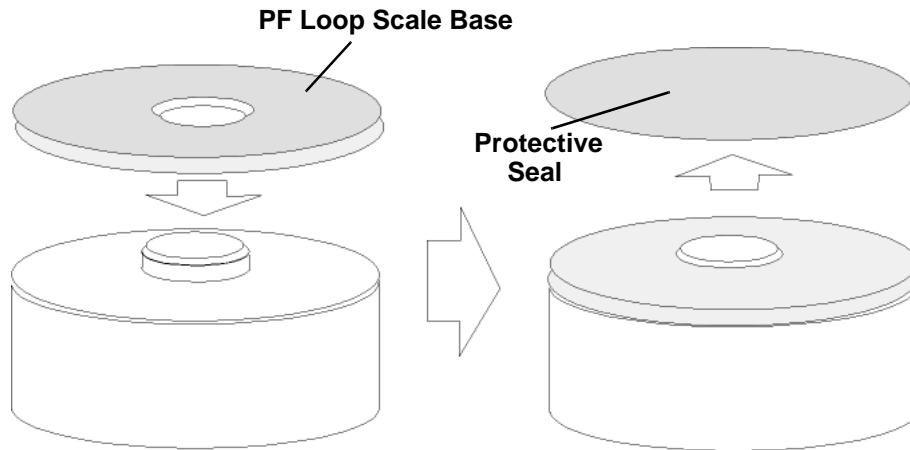

#F730 tool

Figure 4-34. #F730 tool and PF Loop Scale Base

3. Set the PF loop scale with its printed side downward on the PF loop scale base and affix the PF loop scale carefully to the PF loop scale base.

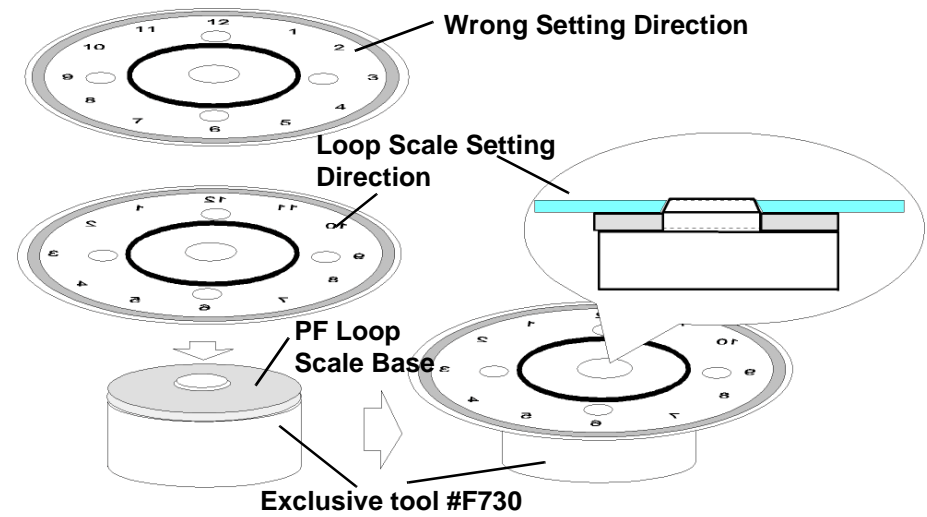

Figure 4-35. PF Loop Scale Set

- **CAUTION** Care should be taken so as not to damage the internal diameter of the PF loop scale.
- There is no problem if the PF loop scale's affixing position on the PF loop scale base deviates somewhat. The important control point is that the inside diameter of the PF loop scale not be damaged.

4. Peel the protective backing off the other side of the double sided tape and affix the tape so that it is within the black circle on the unprinted side of the PF loop scale assembly.

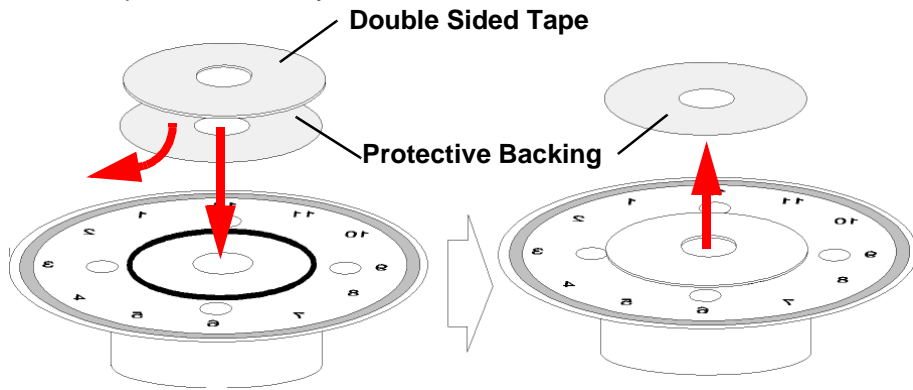

Figure 4-36. Affixing the Double Sided Tape to the PF Loop Scale

□ PF Loop Scale Assembly Affixing Procedure

When assembling the PF loop scale unit, the following exclusive tool should be used.

- Exclusive tool No. #F731 : PF Loop Scale Affixing tool (Code: 1051767)

The assembly procedure is given below.

1. Set the PF loop scale assembly's double sided tape side on the grid roller side, align the internal diameter of the PF loop scale with the left end of the grid roller (PF roller) and set it lightly.



• At this point, the PF loop scale assembly should not be fitted on the grid roller as far as it can go. If the PF loop scale assembly is placed on the grid roller by hand, it could damage the PF loop scale assembly's internal diameter and the distance from the center of the grid roller to the scale reading part would not be the same all around any more, resulting in a drop in the encoder sensor's reading accuracy.

2. Press the exclusive tool #F731 against the PF loop scale assembly from the outside, then insert the grid roller in as far as the base plate carefully, and affix it.

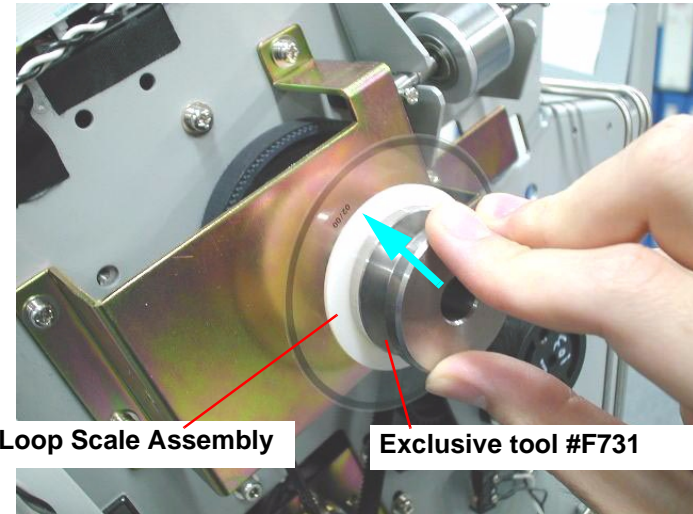

Figure 4-37. Affixing the PF Loop Scale Assembly

4.2.3.7 Removing the PF Motor Pulley Assembly

1. Remove the L side cover. (See 4.2.1.3.)
2. Remove the paper guide L. (See 4.2.1.6.)
3. Loosen the 4 screws (CP(W2) M4 x 12: blue screws in the figure below) holding the X motor mounting plate and release the tension on the X deceleration belt.

CHECK POINT



At the place where the tension is released, workability will be improved if the X motor mounting plate is tightened temporarily.

4. Take out the 2 screws (CP(W2) M3 x 8) holding the PF motor pulley assembly to the X motor mounting plate and remove the PF motor pulley assembly.

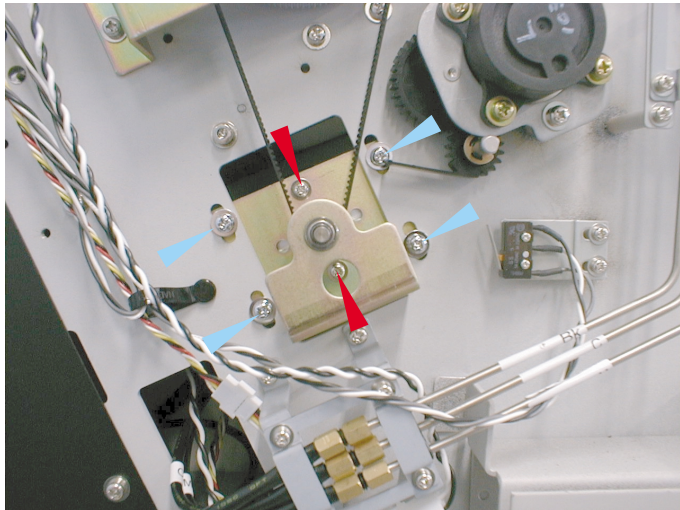

Figure 4-38. Removing the PF Motor Pulley Assembly

5. Push the PF motor inside the printer and remove the PF motor pulley.



If the PF motor pulley is removed, the following adjustments should be made.

- Paper guide L installation position adjustment. Refer to page 204.
- Check the paper cutting position. Depending on the condition, adjust the cutter installation position and adjust the CR cover height. Refer to page 207.
- X belt tension adjustment. Refer to page 213.

4.2.3.8 MAINTENANCE ASSEMBLY REMOVAL & DISASSEMBLY

CAUTION



If the “Service Call 00000100” error occurs, you need to replace the Waste Ink Pads and Box R well as replace the Pump Assembly, Cap Assembly, and Head Cleaner on reset the Maintenance Assembly. In addition, you need to reset the following counters.

- INIT. WASTE INK (see page 38)
- INIT. CREANER (see page 38)

You also need to perform the Cutter Position Adjustment.

ADJUSTMENT REQUIRED



If the Maintenance Assembly is removed, the following adjustments should be made.

- Paper guide L installation position adjustment. Refer to page 204
- Check the paper cutting position. Refer to page 207. Depending on the condition, adjust the cutter installation position and adjust the CR cover height.

1. Remove the paper guide L. (See 4.2.1.6.)
2. Remove the R side cover. (See 4.2.1.3.)
3. Remove the right- side Waste Ink Box.(See 4.2.3.1)
4. Remove the two (CP(W2)M4x6)screws securing the Maintenance Assembly frame to the printer.
5. Take out the 4 screws (CP(W2) M4 x 8) holding the “Deceleration pulley support” on the side of the left side frame.
6. Disconnect the two cables from the connectors CNN9 (to CRL Look Solenoid) and CN19 (to Pump motor), and then remove the Maintenance Assembly.

CAUTION



When removing the Maintenance Assembly, the ink tubes connected to the Pump Assembly may leak or drip ink. It is a good idea to wipe the ends of these ink tubes off before removing the maintenance Assembly.

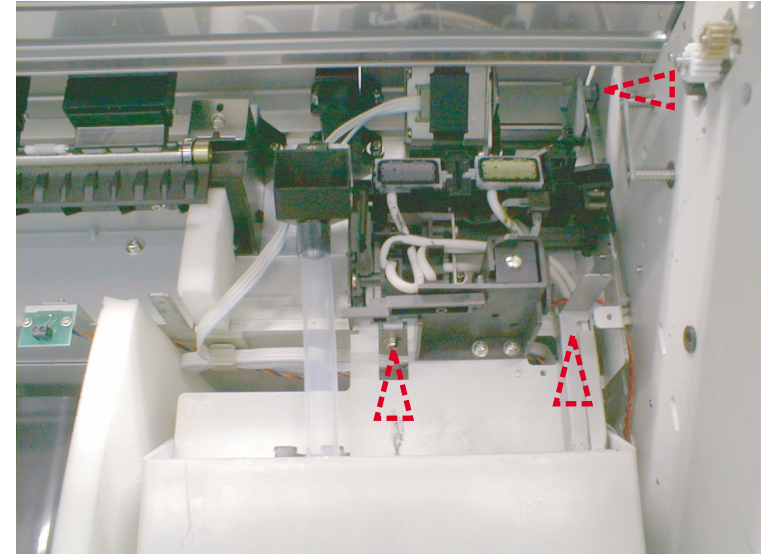

Figure 4-39. Maintenance Assembly Removal - 1

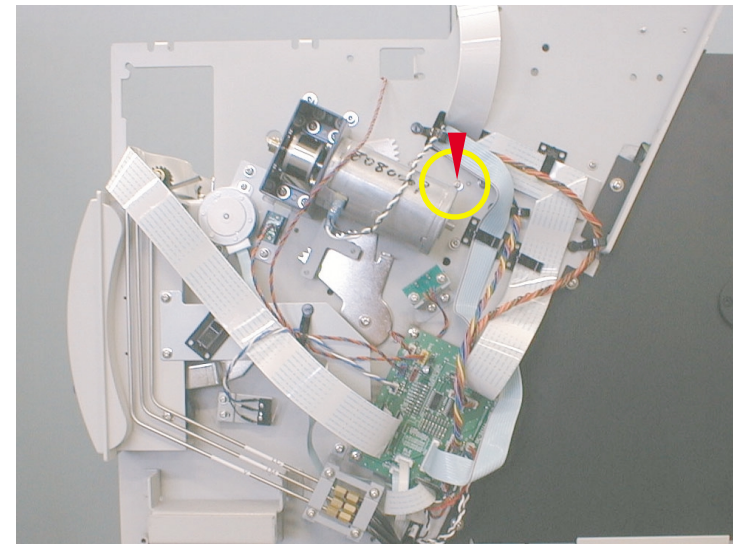

Figure 4-40. Maintenance Assembly Removal - 2

7. After removing the two (CP(W2)M3x6) screws on the side of the Maintenance Assembly, remove the Cap Assembly and the plate. then remove the Pump Speed- Reduction Gear1 as shown below
8. Remove two (CP(W2) M3x6) screws securing the CR Lock, and then remove the CR Lock Assembly (solenoid).
9. Remove one (CP(W2) M3x6 screw securing the Pump Assembly to the Maintenance Assembly Frame, and then remove the Pump Assembly along with the Cap Assembly and plate.

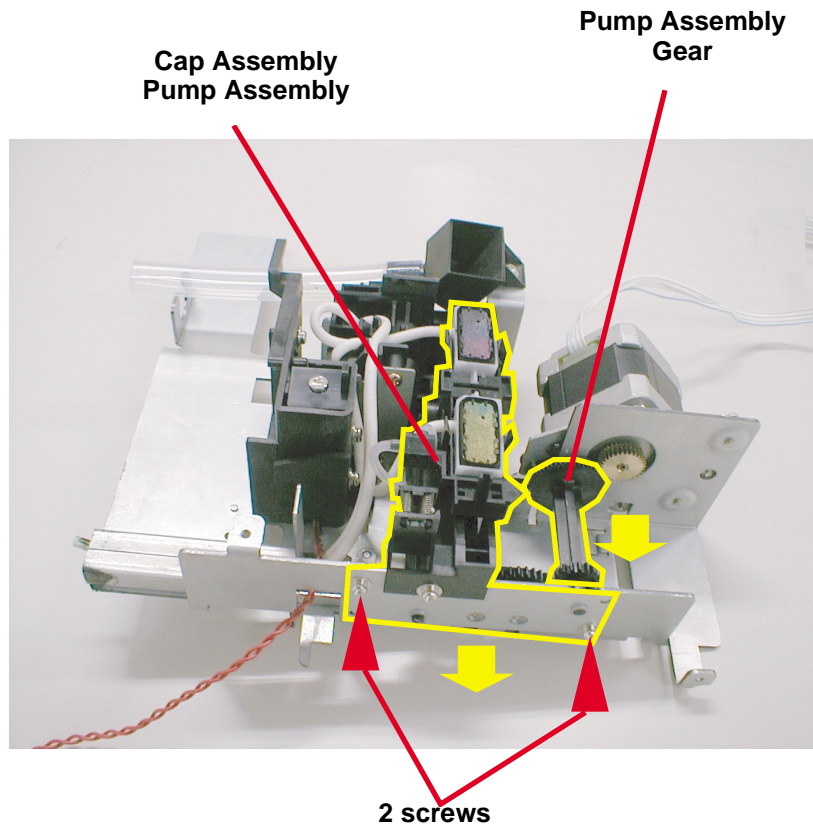

Figure 4-41. Maintenance Assembly disassembled - 1

10. If necessary, disassemble the Cap Assembly and Pump Assembly (remove the ink tubes) and remove the Head Cleaner from the Pump Assembly.



If you plan to re-install the Cap Assembly you removed, keep the following important points in mind.

- After re-installing the spring that holds the cap in place, try moving the cap by hand to make sure it operates properly.
- Make sure there is no leakage around the valve position.

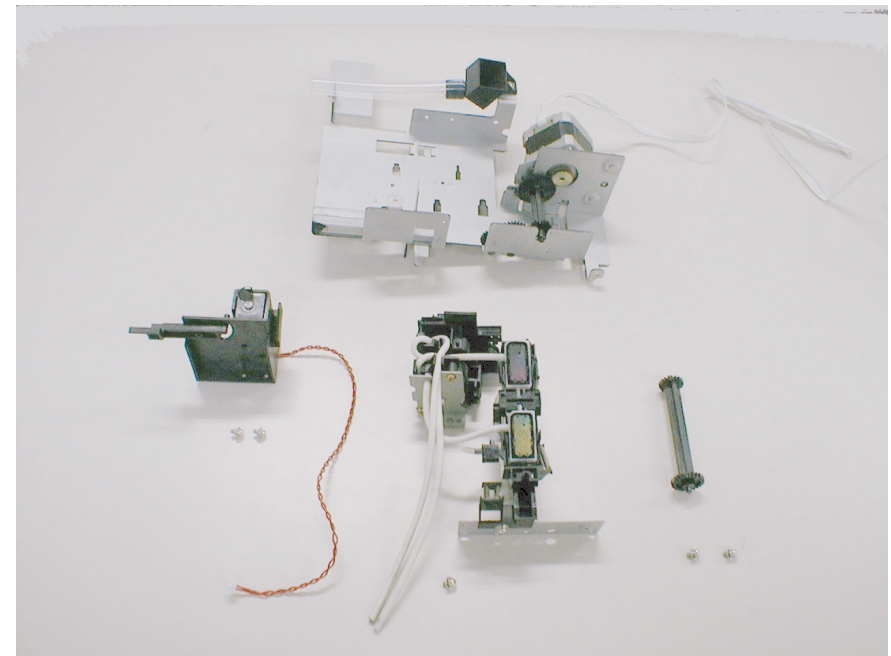

Figure 4-42. Maintenance Assembly disassembled - 2

4.2.3.9 Removing the sensors

1. Remove the L/R side cover.(See 4.2.1.3)
2. To remove the interlock switch (R), disconnect the cable from the connector CN13 on the relay board.
3. Remove the two screws (CP(W2) M3x6) securing the interlock switch mount plate to the side frame, and remove the interlock switch (R) together with the mount plate.

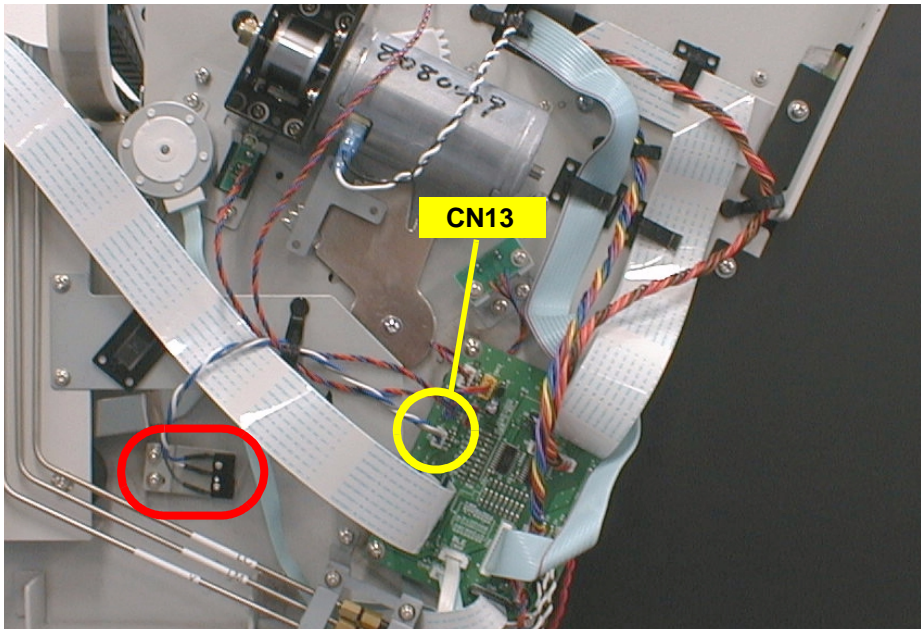

Figure 4-43. Interlock Switch (R) removal

4. To remove the interlock switch (L), disconnect the cable from the connector CN27 on the C277MAIN board.
5. Remove the two screws (CP(W2) M3x6) securing the interlock switch mount plate to the side frame, and remove the interlock switch (L) together with the mount plate.

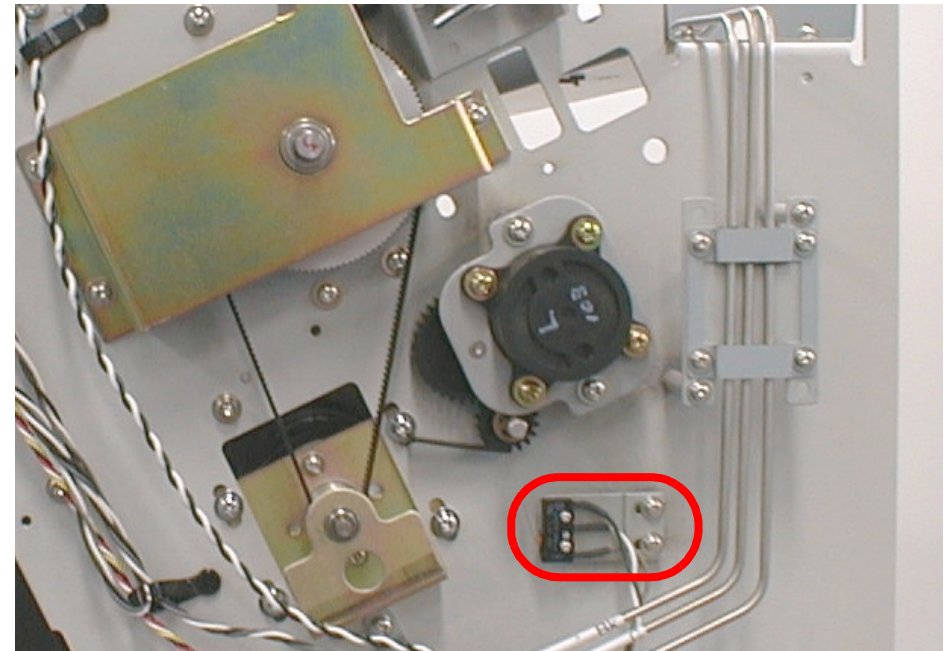

Figure 4-44. Interlock Switch (L) removal



When the interlock switch has been removed, the following adjustment should be made.

- Cover R/L Sensor Assembly Adjustment (Interlock switch position adjustment) (Self-diagnostic Mode)
Refer to page 215.

REMOVING THE P_THICK SENSOR

1. Remove the H-TOP cover.(See 4.2.1.2)
2. Disconnect the cable from the connector CN12 on the relay board.
3. Remove the two screws (CP(W) M3x6) securing the sensor assembly, and remove the P_THICK sensor together with the mount plate.

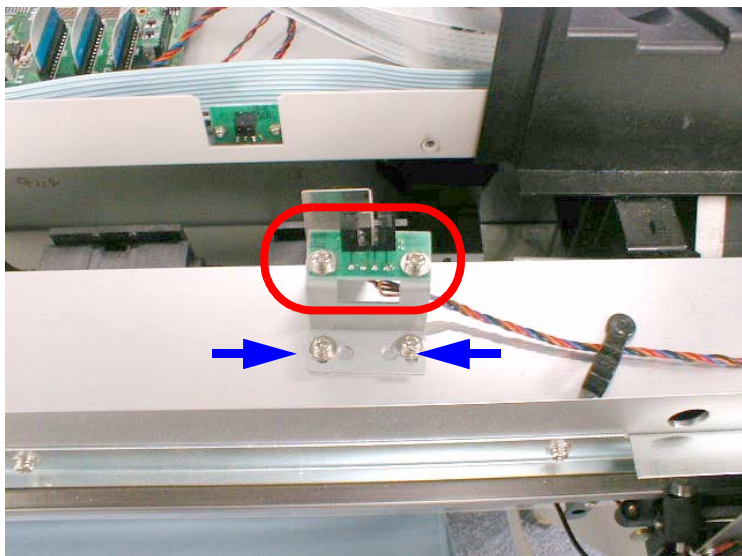

Figure 4-45. P_THICK sensor removal

ADJUSTMENT
REQUIRED



When replacing the P-THICK sensor, the following item should be checked.

- P-THICK sensor assembly adjustment (Self-diagnostic mode). Refer to page 215

REMOVING THE P_REAR SENSOR

1. Remove the upper paper guide.(See 4.2.1.7)
2. Disconnect the cable from the connector CN11 on the C277MAIN board.
3. Remove the one screws (CP(W) M3x6) securing the sensor assembly, and remove the P_REAR sensor together with the mount plate.

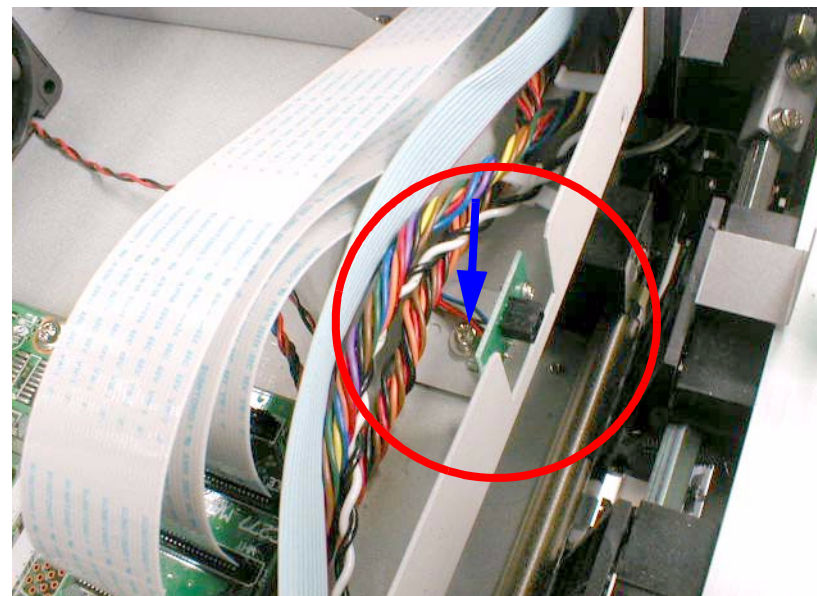

Figure 4-46. P_REAR sensor removal

ADJUSTMENT
REQUIRED



When replacing the P-REAR sensor, the following adjustments should be made.

- P-REAR sensor VR adjustment. (Self-diagnostic mode). Refer to page 192.
- Rear sensor position adjustment. (Self-diagnostic mode). Refer to page 184.

REMOVING THE P_FRONT SENSOR

1. Remove the lower paper guide.(See 4.2.1.6)
2. Disconnect the cable from the connector CN11 on the relay board.
3. Remove the one screws (CP(W) M3x6) securing the sensor assembly, and remove the P_FRONT sensor together with the mount plate.Position the screw in the back of the mounting plate.

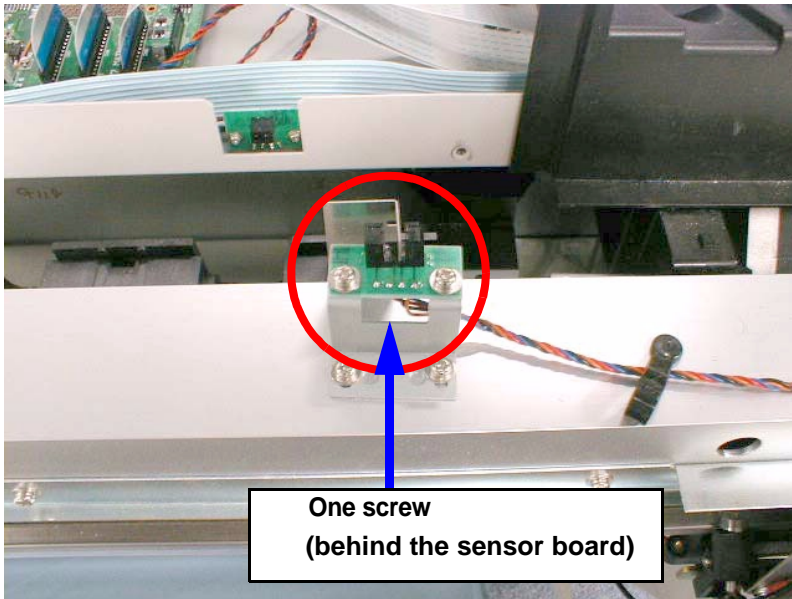

Figure 4-47. P_FRONT sensor removal



When removing the P-FRONT sensor, the following adjustment should be made since the paper guide L will be removed.

- Paper guide L installation position adjustment. Refer to page 204.
- Check the paper cutting position. Refer to page 207.

REMOVING THE LEVER POSITION SENSOR / HD_SLID HP SENSOR

1. Remove the side cover R.(See 4.2.1.3)
2. Disconnect the cable from the connectors on the relay board.
CN17 = to HD_SLID HP sensor
CN10 = to LEVER POSITION sensor
3. Remove the two screws (CP(W) M3x6) securing each sensor assembly, and remove the LEVER POSITION / HD_SLID HP sensor together with the mount plate.

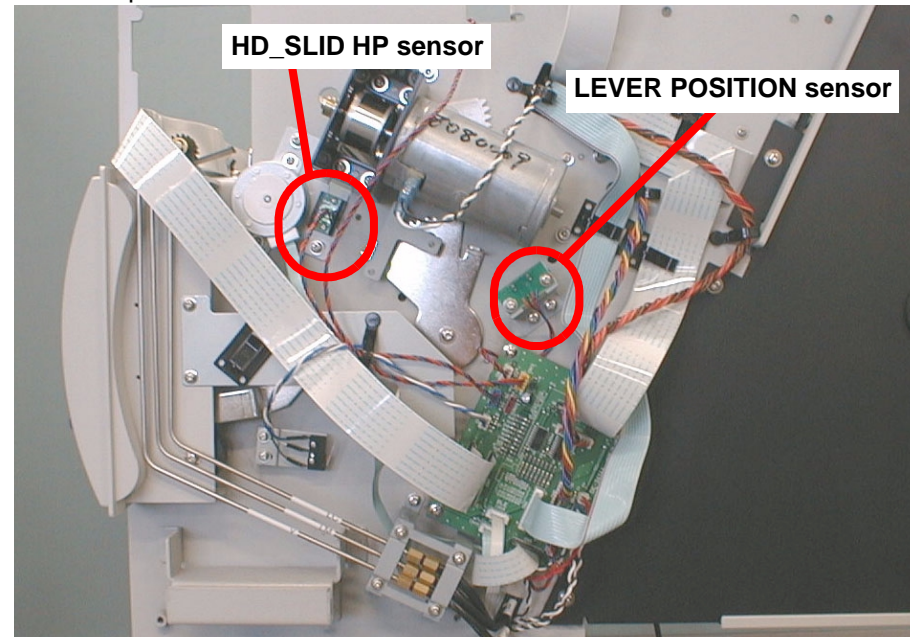

Figure 4-48. LEVER POSITION / HD_SLID HP sensor removal



When removing the head SLIDE HP sensor, the following item should be checked.

- SLIDE motor assembly backlash adjustment. Refer to page 214.

REMOVING THE CR-HP SENSOR AND ENCODER

1. Remove the H-TOP cover.(See 4.2.1.2)
2. Take out the 2 screws (CP(W) M3 x 6) holding the CR relay board cover.
3. Disconnect the cables from the connectors on the CR-RELAY board:
 CN3 = to CR-HP Sensor
 CN2 = to Linear Encoder

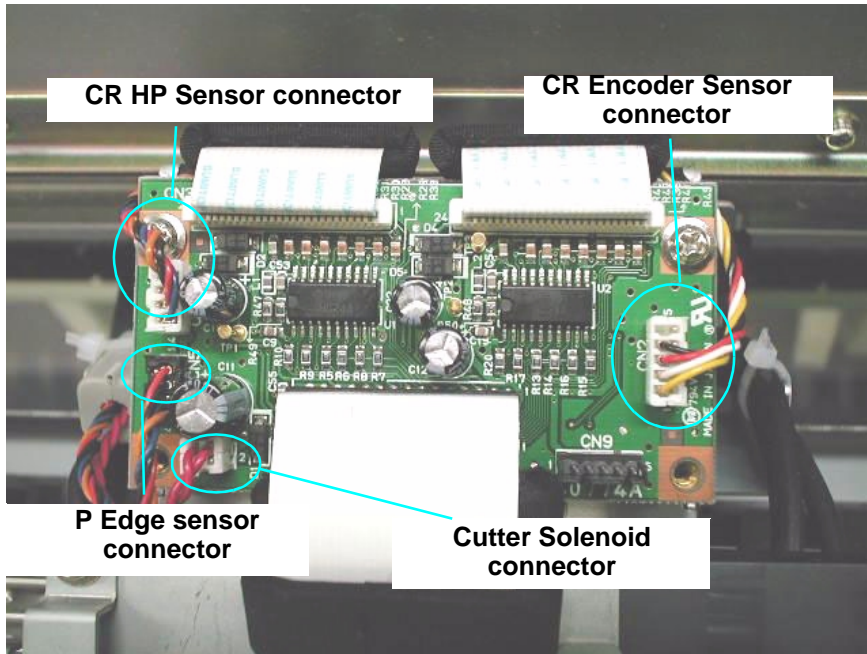

Figure 4-49. Disconnect the cables

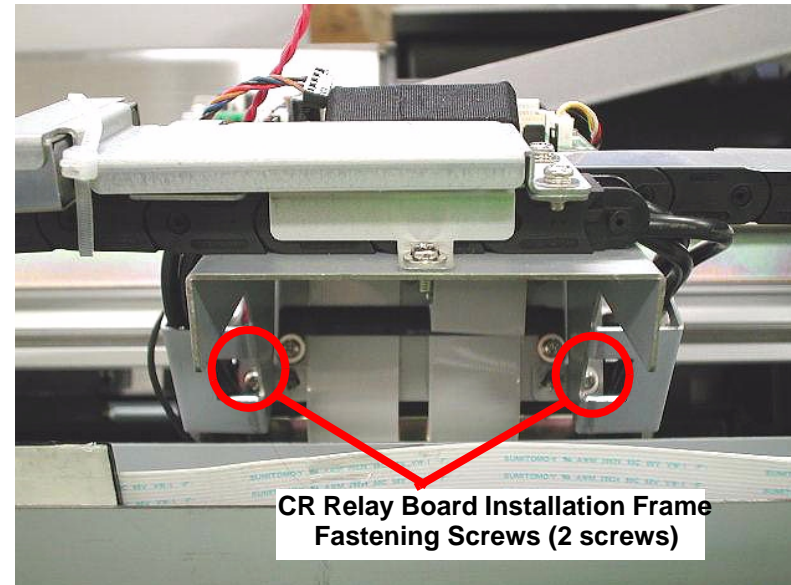

Figure 4-50. Removing the screws (L/R)

4. Take out the 2 CR relay board mounting frame installation screws.



Do not damage the timing fence (slit film) when removing / attaching the encoder.

- Slide the CR relay board mounting plate toward the front of the printer.
- Remove the 2 screws (CP(W2) M3 x 6) each, then remove the HP sensor and encoder from the back of the CR relay board mounting plate.

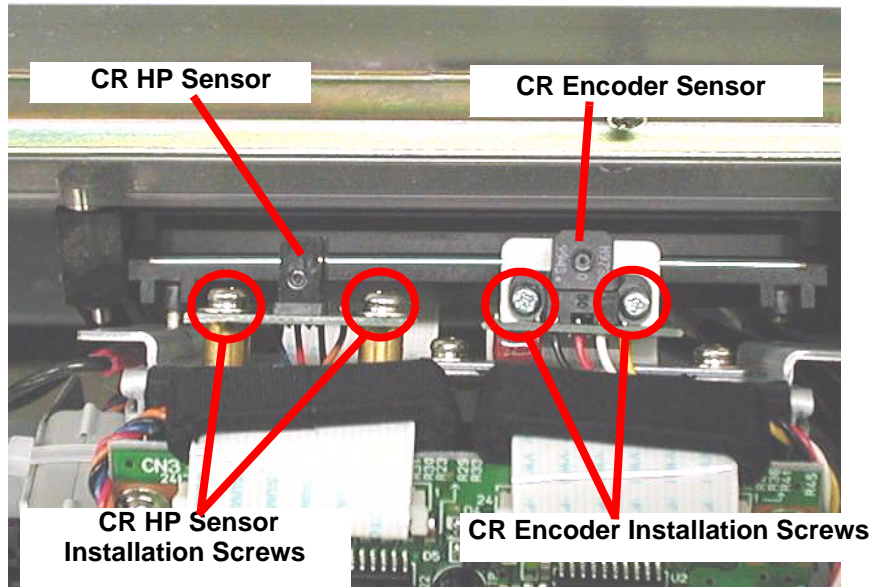

Figure 4-51. Fig. 4-51 Removing the CR HP Sensor and Encoder Sensor



If you have removed the CR encoder sensor, the following adjustment is necessary.

- CR encoder sensor installation position adjustment. Refer to page 210.

4.2.3.10 Ink System Mechanism Disassembly

This section describes the Ink System Mechanism components and the procedure for disassembly.

CAUTION



Removing and re-installing the ink system mechanism components requires ink discharge and initial charge operation. Refer to page 167 of the Chapter-5 Adjustment for the detail procedures.

REMOVING THE I/C HOLDER ASSEMBLY

1. Perform ink discharge operation to eject inks from all ink paths.
2. Remove the side covers (L/R) (See 4.2.1.3)
3. Remove the four screws (CP(W2) M3x6) securing the ink tube fixing plate, and loosen the lock nut securing the ink tubes to the ink pipes and disconnect the ink tubes from the ink pipes.
4. Remove the four screws (CP(W2) M2x4) securing the access cover attached at the back of the I/H assembly.

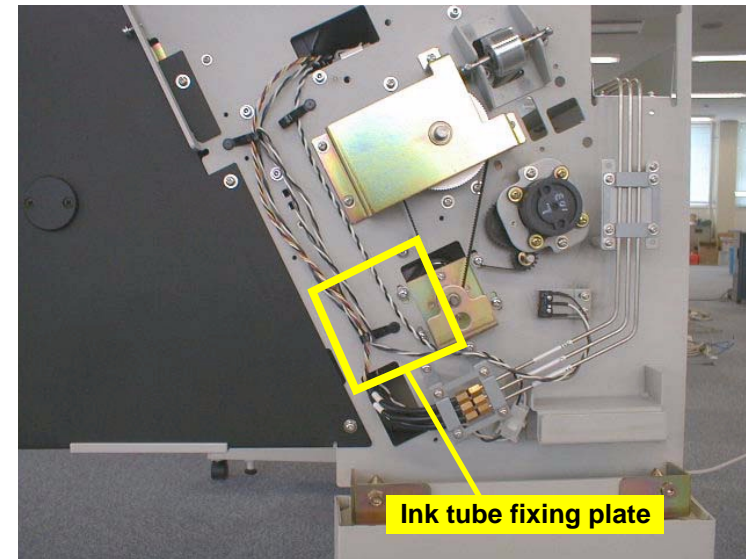

Figure 4-52. Disconnecting the ink tubes

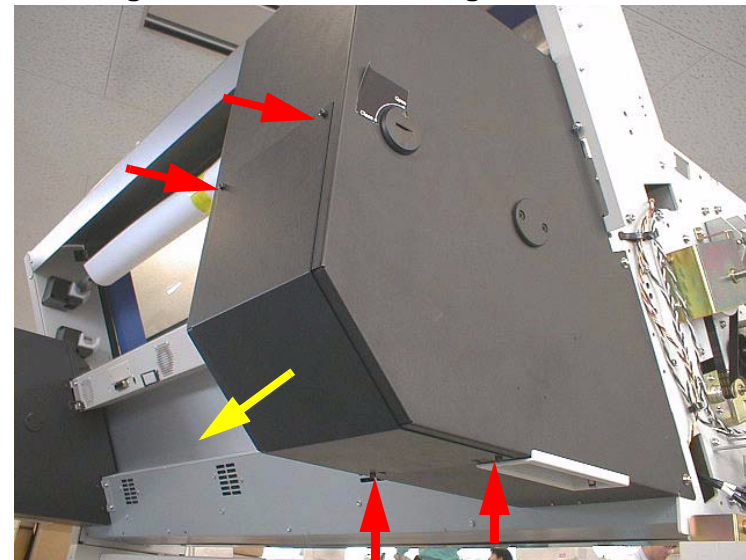

Figure 4-53. Removing the access cover

5. Loosen two screws securing the fixing plate that holding the ink tubes and a FFC inside the I/H assembly. And unhook two tabs and remove the hand hold cover.
6. Remove the two screws (CP(W2) M3x6) securing the ink tube holder plate, and disconnect the FFC from the connector CN1 on the I/H relay board attached at the bottom of the I/H assembly.

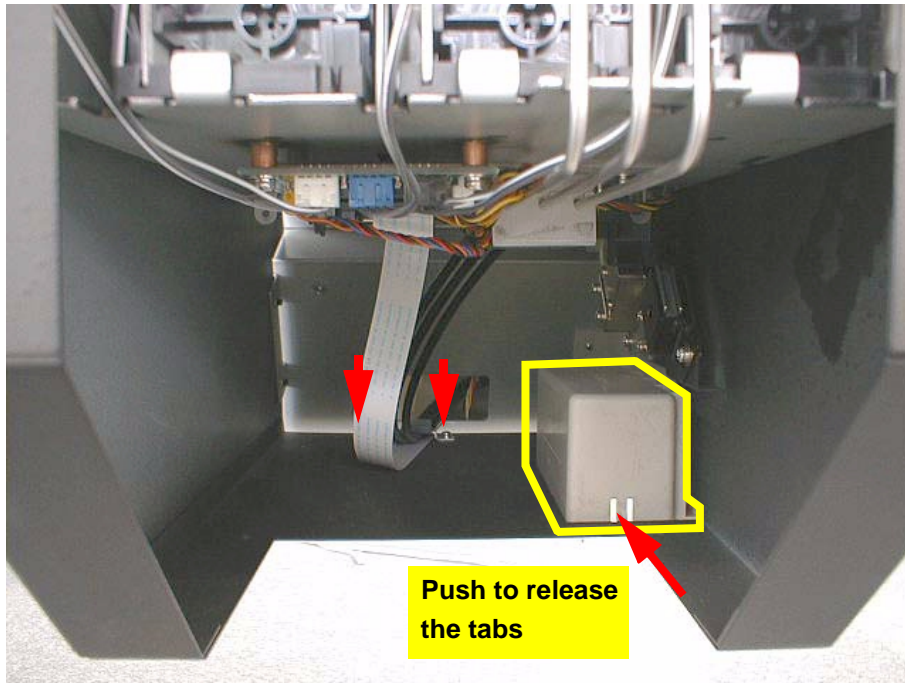

Figure 4-54. Removing the fixing plate



To remove two screws securing the ink tube holder plate, you need a short-neck screwdriver.

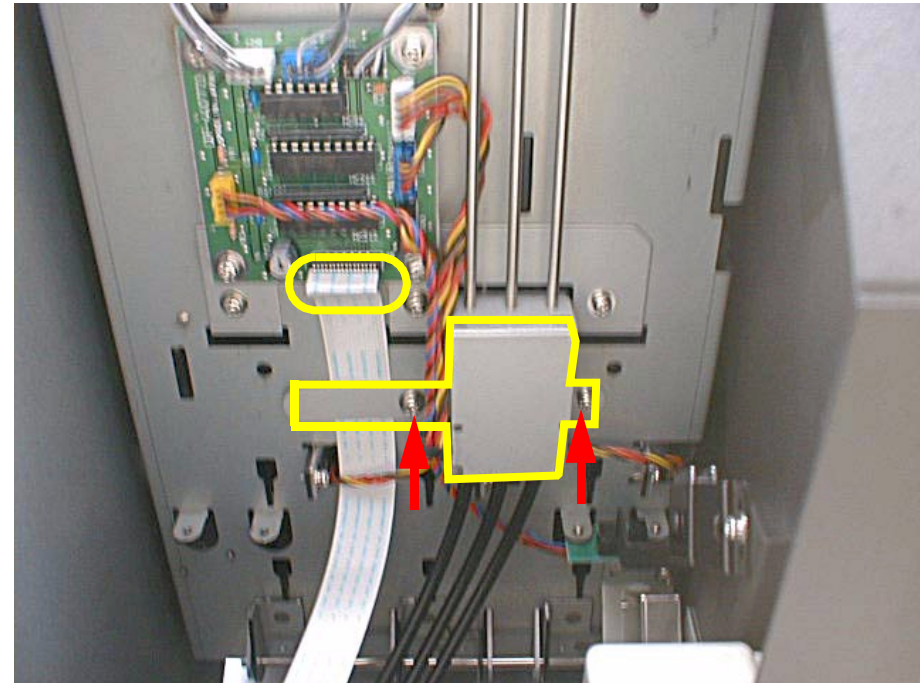

Figure 4-55. Removing the FFC

7. Remove the seven screws (CP(W2) M4x6) securing the I/H assembly to the printer mechanism, and slightly push it up as to unhook the assembly from the side frame of the printer mechanism.
8. Remove the six screws (CP(W2) M2x4) securing the side cover of the I/H assembly and remove the side cover.
9. Slightly rotate the I/C holder assembly so that the assembly is released from the lock lever unit. Then, remove the two screws (CP(W2) M3x6) securing the friction gear assembly and remove it.

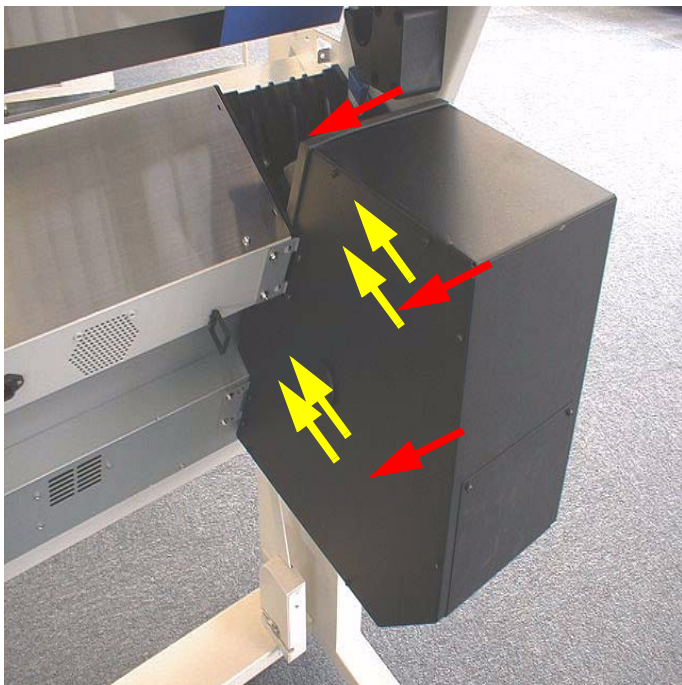

Figure 4-56. Removing the screws (4 pcs)

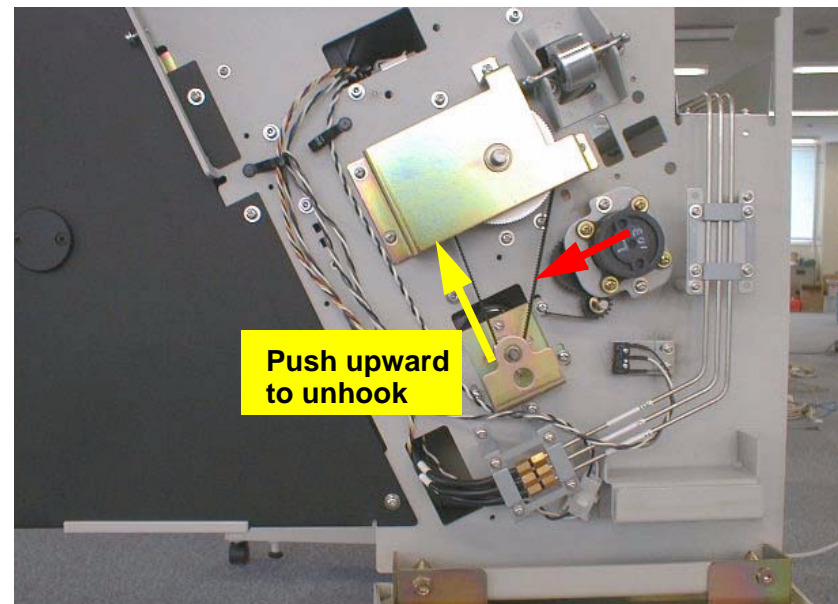

Figure 4-57. Removing the screws (3 pcs)

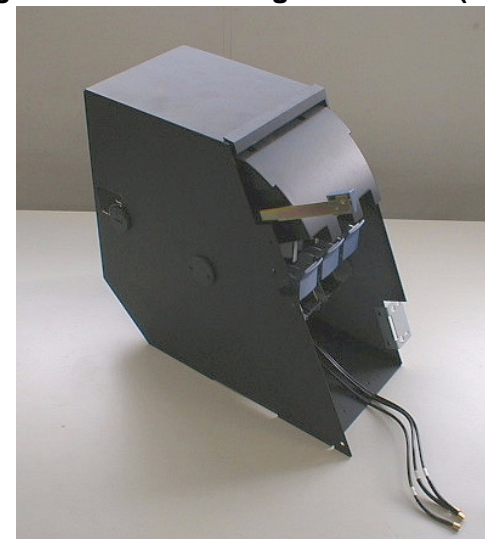

Figure 4-58. I/H Assembly

DISASSEMBLING THE I/H ASSEMBLY

1. Take out the 6 screws (CP(W2) M2 x 4), then remove the I/H assembly from the side cover.
2. Rotate the internal cartridge holder assembly until the lock is released. Next, take out the 2 screws (CP(W2) M3 x 6) holding the friction gear assembly and remove the friction gear assembly.

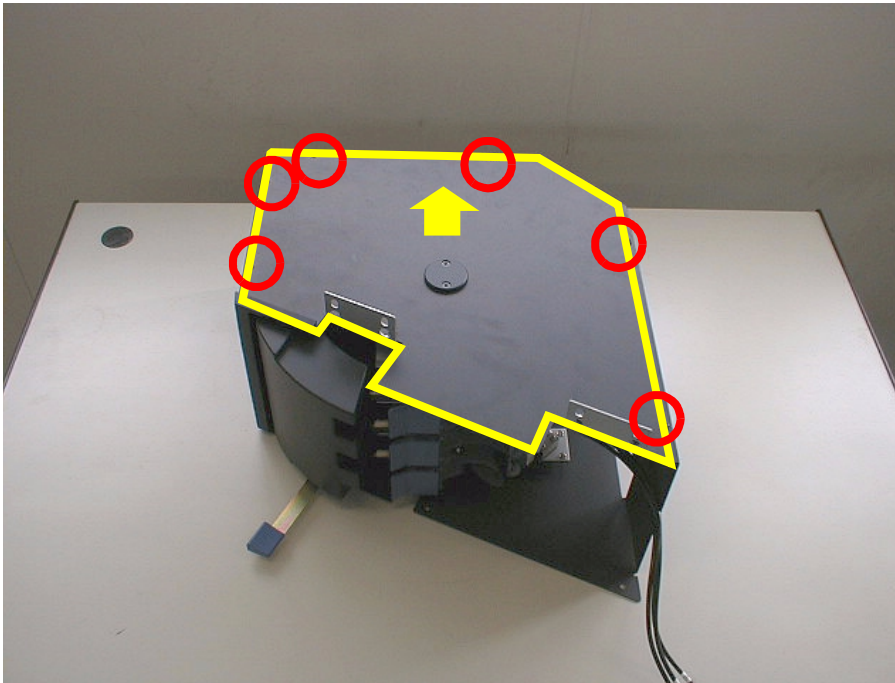

Figure 4-59. Removing the side cover of I/H assembly

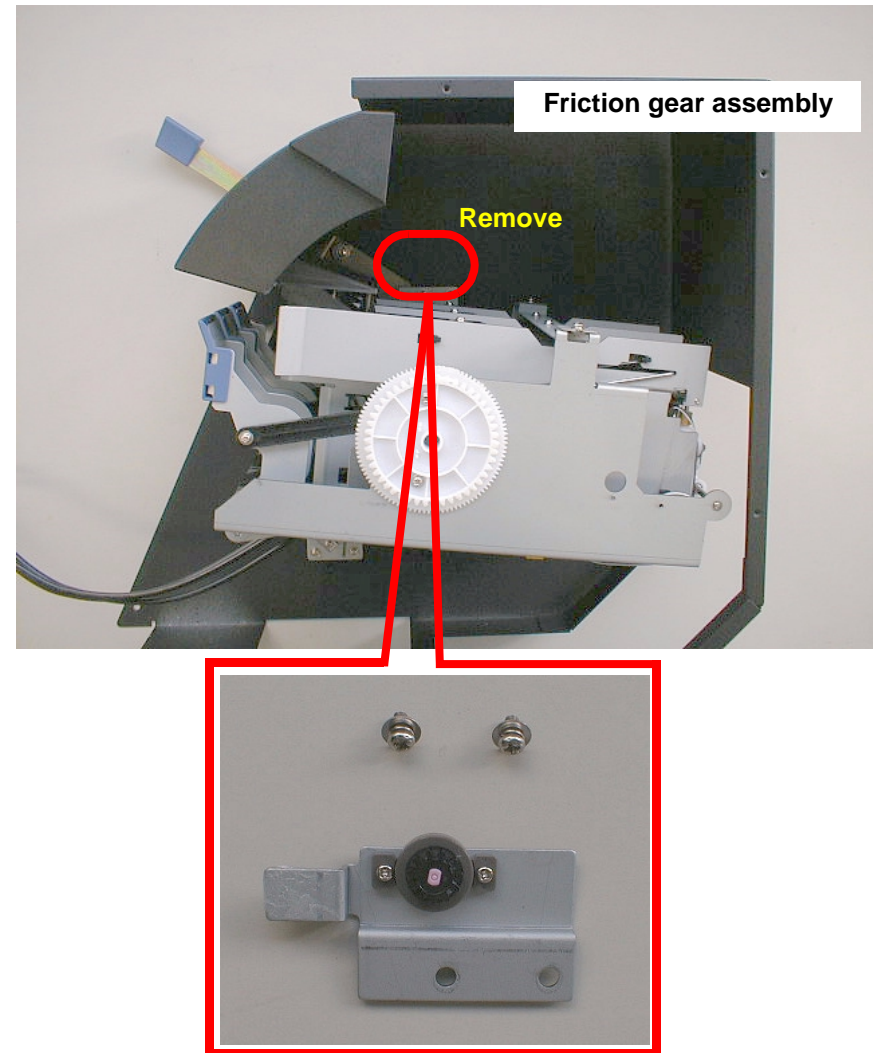

Figure 4-60. Removing the friction gear assembly.

3. Set the I/H assembly frame down, then lift the cartridge holder assembly straight up and remove it.
4. Take out the 2 screws (CP(W2) M3 x 4), then remove the I/C cover. Next take out the 5 screws (2 screws = CP(W2) M3 x 4, 3 screws = P tight M3 x 4), then remove the I/C holder fastening plate.
5. The I/C holders are each independent of the other, so they can be removed individually. If you are removing one I/C holder, first, take out the 1 screw (CP(W2) M3 x 4) holding the I/C holder to the base frame.
6. Overturn the entire cartridge holder assembly, then take out the screw (CP(W2) M3 x 4) holding the I/C holder from the bottom surface of the base frame.

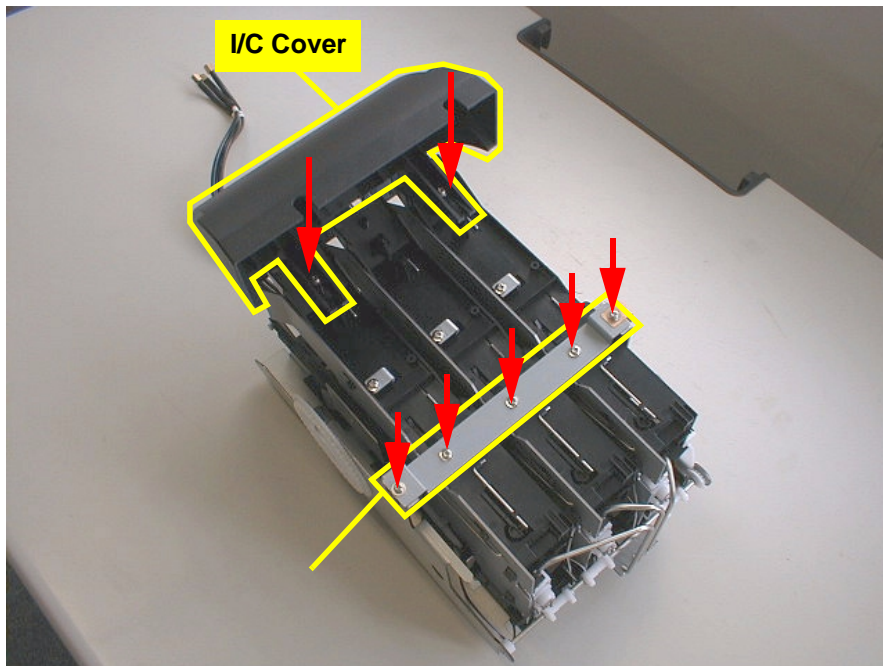

Figure 4-61. Removing the I/C cover and the fixing plate

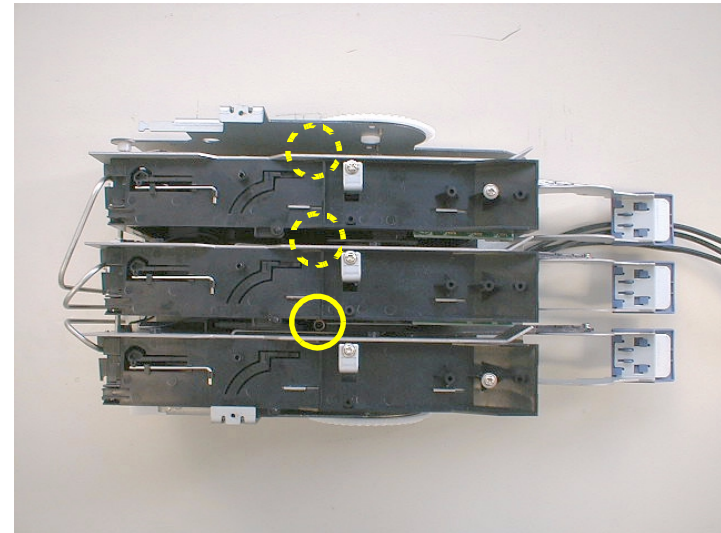

Figure 4-62. Removing the screw (from the top)

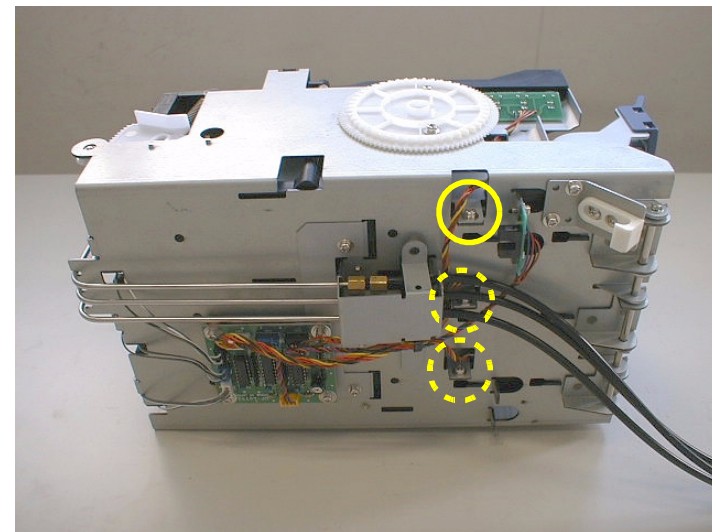

Figure 4-63. Removing the screw (from the bottom)

7. Turn the I/C holder that is being removed on its back, then loosen the hex nuts to the ink pipes installed in "Holder assembly, valve, A" and remove the ink pipes.
8. Disconnect the cable corresponding to the I/C holder that is being removed from the I/H relay board on the bottom of the cartridge holder assembly.

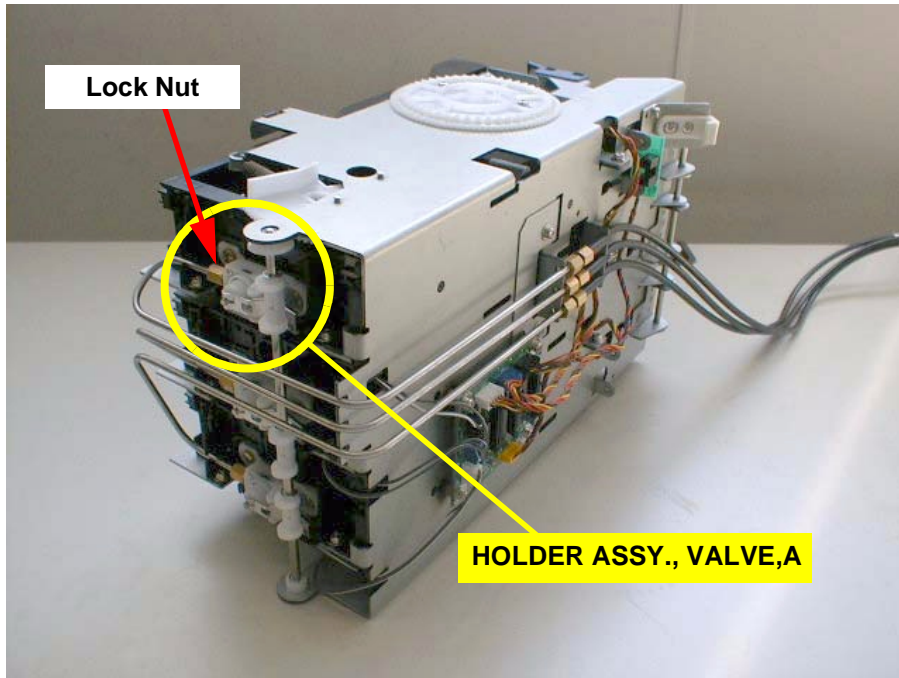

Figure 4-64. Removing the ink pipe

Table 4-4. Connection between each I/C holder and relay board

I/C Holder	I/C ID sensor	I/C In sensor Ink low sensor
Black (Light Cyan)	CN3	CN4
Cyan (Light Magenta)	CN5	CN6
Magenta (Yellow)	CN7	CN8

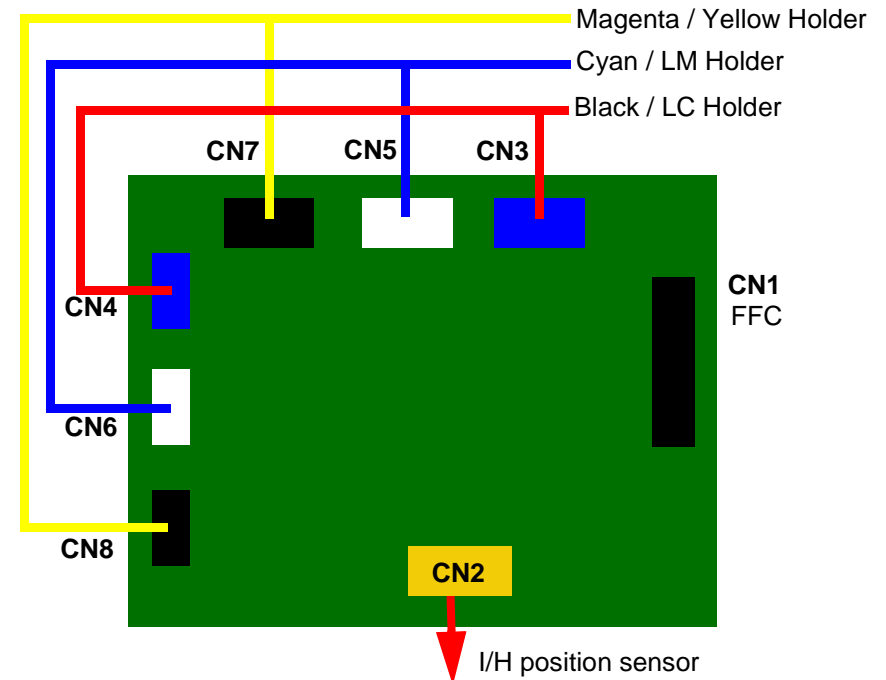

Figure 4-65. Connector location on the I/H relay board

9. Remove the one screw (CP(W2) M2x4 with a metal bushing) securing the I/C link to the I/C eject lever.
10. Remove the I/C holder assembly from the I/H assembly.

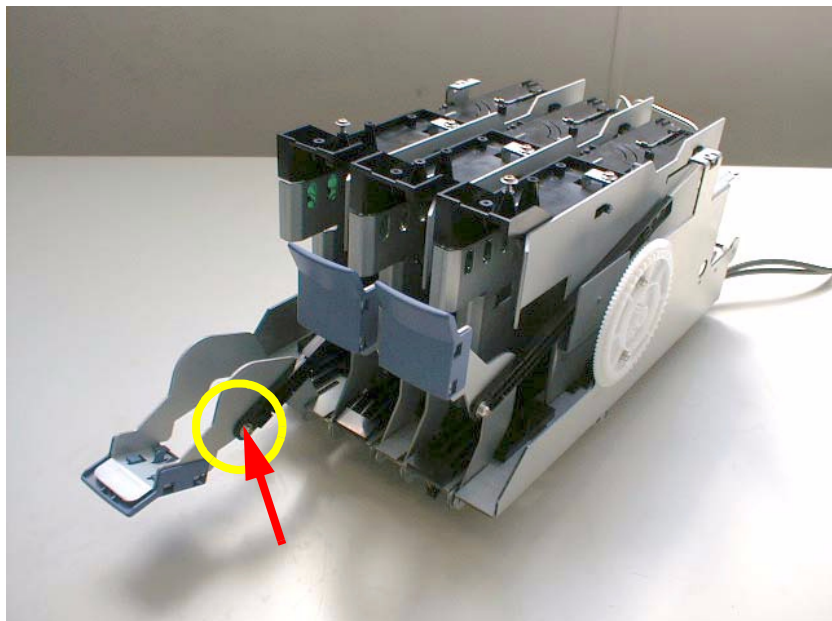

Figure 4-66. Removing the screw (I/C link)

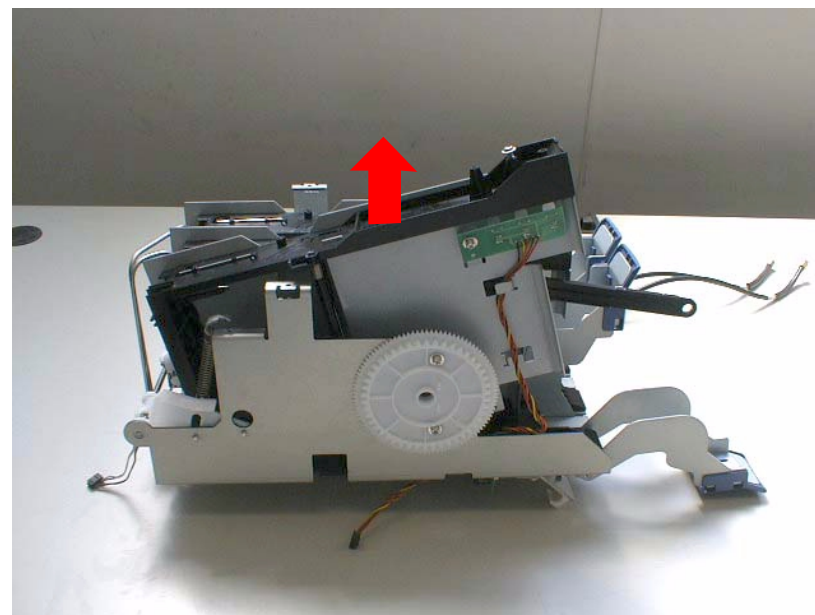

Figure 4-67. Removing the I/C holder

DISASSEMBLING THE I/C HOLDER

1. Unhook the hooks fixing the upper I/C guide and slide it backward. Then, slide out a metal bracket that holds the I/C ID sensor board.
2. Remove the two screws (CP(W2) M3x4) securing the "HOLDER ASSY., VALVE, A" to a base frame.
3. If necessary, remove the I/C In sensor assembly or the Ink Low sensor assembly.

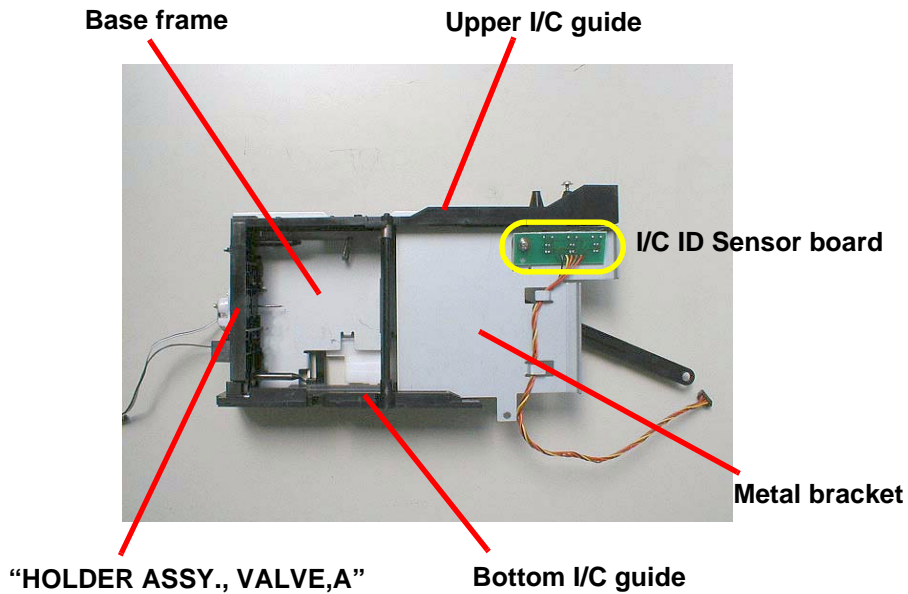

Figure 4-68. I/C Holder

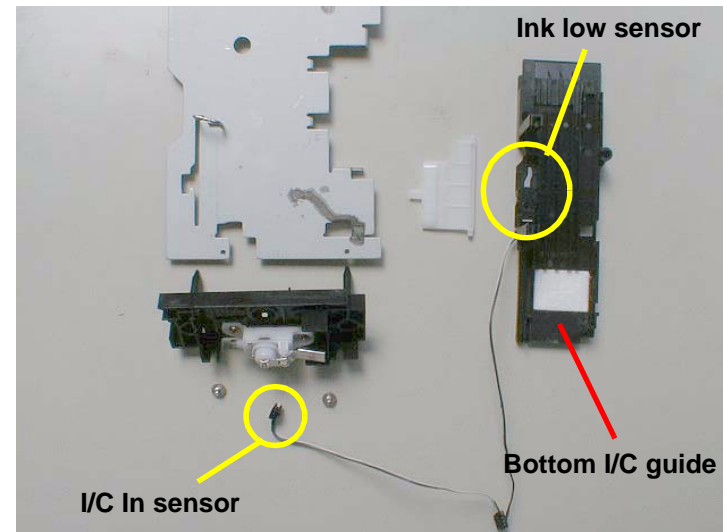
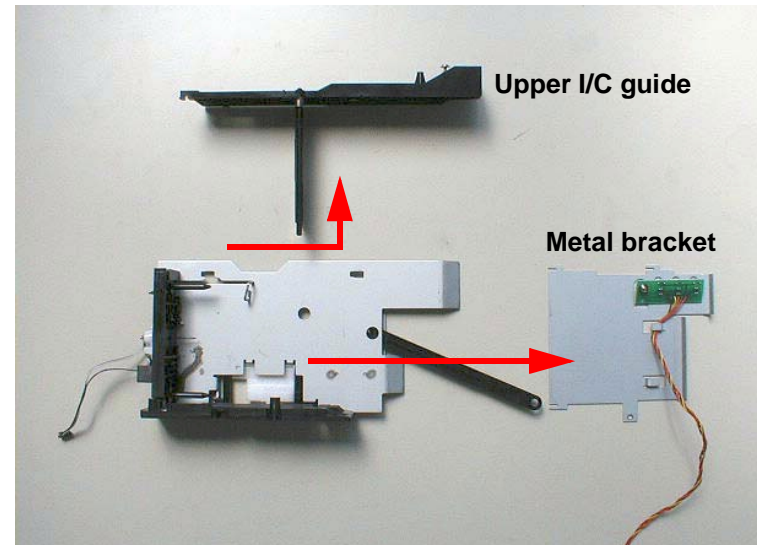

Figure 4-69. I/C Holder Disassembly (1) (2)

4.2.4 Conversion Kit

4.2.4.1 Conversion Kit Component Parts

This kit is a kit which upgrades the Stylus Pro 9000 from a printer that uses dye-based inks to one which uses pigment-based inks, and is configured from the following parts.

Table 4-5. Conversion Kit Component Parts

Part Name	Quantity
• Maintenance Kit: 1 Kit	• 1 Kit
• MC Thick Mat Paper roll 44" x 5 m	• 1 Roll
• Document Pack	• 1 Kit
• Damper Assembly	• 6 pcs.
• O-rings	• 6 pcs.
• Joint Screws M6	• 6 screws
• Ink Cartridge Model No. Labels	• 2 labels
• EPSON _COLOR FAST Label	• 1 label
• Manual Cutter Cut Position Label	• 1 label
• Ink Cartridges	• 6 cartridges
• Transport Liquid S46 Cartridges	• 6 cartridges

The parts code for the Conversion kit is different each market as following table because the document pack is different each market.

Table 4-6. Conversion kit parts code

Market	Parts Code	Document pack
ETT	1059326	packed
ECC	1059325	packed
Other	1059327	packed
EAI, EIB, EIS, EFS, EDG,	1058466	Not packed

NOTE: The document pack is not packed in the Conversion kit for EAI, EIB, EIS, EFS, EDG in our manufactory. These subsidiaries must pack your document pack for each pigment product in your warehouse yourself before you use this conversion kit.

NOTE: A PC card or CD-ROM with the latest firmware written to it is not packed with this kit, so when implementing the upgrade service, a PC card or CD-ROM with the latest firmware written to it should be brought together with this kit.

NOTE: This kit does not include a CPS Soft Ripper or Postscript Server system disc, so a system disk or materials which are compatible with the customer's use environment should be brought together with this kit.

4.2.4.2 Required Adjustment Item

In the upgrade service, if the necessary parts are assembled, the necessary adjustment items are as shown below.

Table 4-7. Adjustment Items

No	Adjustment Items
1	Paper guide L installation position adjustment
2	Cutter mounting position adjustment
3	CR cover height adjustment
4	Paper cutting position adjustment
5	Bi-d Adjustment
6	Head GAP adjustment
7	P-EDGE / FRONT / REAR sensor adjustment

4.2.4.3 Upgrade Service Preliminary Cautions

The following contents concerning this service should be adequately explained to the user and the service performed after the user gives his or her consent.

- Most of the print media used with the Stylus Pro 9000, with the exception of the following media, will no longer be usable with the printer.
 - MC thick mat roll paper
 - Glossy film roll paper
- When the upgrade service has been performed, the dye-based ink cartridges used with the Stylus Pro 9000 cannot be used.
- The OLFA manual cutter is not packed with this conversion kit. Also, the paper guide L with auxiliary grooves for use with the OLFA manual cutter, is not packed with this kit. Therefore, even after this service is performed, the OLFA manual cutter which could be used with the Stylus Pro 9500 cannot be used on machines that have undergone this upgrade.
- If this upgrade service is performed, CPS Ripper - Pro and Postscript Server PS6100 also need to be upgraded.

4.2.4.4 Upgrade Service Preliminary Check Items

When engaging in this service, be sure to confirm the following items.

- It should be confirmed whether CPS Ripper Pro and Postscript Server are installed in the system environment that uses the Stylus Pro 9000. If this service is performed for users which are using the Stylus Pro 9000 under these environments, the following system disks and materials should be brought together with this kit when the service is performed.
 - Users who are using Postscript Server PS6100.
 - PS6300 System Software CD-ROM
 - Boot ROM program
 - SCSI CD-ROM drive
 - Users using CPS Soft Ripper PRO
 - Soft Ripper PRO software package.

- The results of the nozzle check of the Stylus Pro 9000 currently in use by the user should be checked. If missing of dots is occurring, carry out head cleaning 3 times and if it still doesn't recover, use a light system head, regardless of whether the head causing the dot missing is a dark system head or a light system head (ASP Code: F055050), and this should be brought together with this kit and the other materials when the service is performed.

The purpose of preparing a light system head is that its printing precision is higher compared to that of the dark system head and it is effective in solving the problem of banding when users report banding problems, and prevents it from recurring, thus eliminating customer claims in this area.

- If the customer purchases MC mat synthetic paper or MC mat synthetic paper (with adhesive) when this service is contracted for, depending on the conditions, it is recommended that the optional 2-inch high tension spindle be used together with it.

This paper is structurally weak and has a tendency to deflect more than necessary between the spindle and PF roller during paper feed, so if 4 m or greater lengths of paper are printed on, there is a possibility that wrinkles could occur at the PF roller. Therefore, the optional 2-inch high tension spindle, with its high back tension, is effective when used together with this paper.

- If the customer purchases Watercolor Paper - Radiant White when this service is contracted for, depending on the conditions, it is recommended that the optional 3-inch high tension spindle be used together with it. This paper is structurally extremely weak and has a tendency to deflect by becoming unwound between the spindle and PF roller during paper feed. Therefore, the optional 3-inch high tension spindle, with its high back tension, is effective when used together with this paper.

4.2.4.5 Conversion Kit Assembly Procedure

PREPARATIONS

1. Open the Conversion Kit case and check if all the parts have been packed. See table 4-5.
2. Remove the roll paper currently set in the Stylus Pro 9000 the user is using. Install the 44-inch thick mat roll paper packed with the conversion kit in the printer.
3. By switching the power ON while pressing the following buttons, enter the self-diagnostic mode.
 - Paper Feed – Button + Cut / Eject (Enter) Button + Cleaning Button
4. Press the [SelcType] button to select the “Check: Print” item, then press the [Enter (Cut/Eject)] button. (This is, after all, a confirmation operation for the sake of reference.)
5. Press the [Paper Source] button to select “Print: Nozzle Check”, then press the [Enter (Cut/Eject)] button and the nozzle check pattern will be printed. (The nozzle check pattern, Bi-D, Gap pattern and each type of counter value are printed.)

NOTE: *The nozzle check pattern is used in the final confirmation of this operation, so after printing, keep this printout as a treasure until the operation is completed.*

6. Check all segments are printed in the nozzle check pattern again. If any segment has dot missing, perform one of the manual cleaning in [Check: Cleaning]. (St. KK0 < St. KK1 < Std. KK2). In case the dot missing is not recovered by the manual cleaning, prepare the ASP print head before start the Upgrade service
7. Set the paper set lever so it is toward the back of the printer and roll up the paper. After that, the paper set lever should be set so it is toward the front of the printer.



The above nozzle check pattern printout should be carefully kept until this operation is completed. Depending on the firmware version printed out by this function, the adjustment method for the P_EDGE / FRONT / REAR sensors in the adjustment stage will differ.

INK DISCHARGE PROCEDURE

1. Enter the Self-diagnostic mode by turning the printer’s power switch ON while pressing the following buttons.
 - Paper Feed – Button + Cut / Eject Button + Cleaning Button
2. Select “Check: Adjustments” by pressing the [SelcType] button, then press the [Enter] button. After that, press the [Paper Source] button to select “Adj: Clean Head,” then press the [Enter] button.



When you use the [Adj: Clean Head] function in the Self-Diagnostic Mode, lower the Paper set lever certainly. Otherwise, printer dose not work correctly and you can not use the Ink drain & washing function.

3. In accordance with the instruction “Please Remove ink” displayed in the LCD panel, remove all the ink cartridges.
4. In accordance with the instruction displayed in the LCD, “Please lower Ink Lever”, lower the I/H lever, then press [Enter] button to start the ink discharge sequence. This operation ends in approximately 3.5 minutes and during execution, the message “Cleaning” will be displayed in the LCD.
5. After the ink discharge sequence is completed, the message “Set cleaning jig” will be displayed in the LCD panel. Remove the 6cartridges of the S46 transport liquid cartridge form the Conversion Kit and set them in the I/H assembly, then lower the I/H lever.
6. Press the [Enter] button to start the cleaning sequence. While this sequence is running, the message “Head Cleaning” will be displayed in the LCD. This sequence is a process of cleaning the ink supply channel, such as the heads and ink tubes, and ends in approximately 5.5 minutes.

7. After the cleaning sequence is completed, the message "Remove cleaning jig" will be displayed in the LCD, so remove the 6cartridges of S46 transport liquid cartridge from the I/H assembly and lower the ink set lever.
8. Press the [Enter] button to start the transport liquid discharge sequence. During execution of this sequence, the message "Head Cleaning" is displayed in the LCD. This sequence discharges the S46 transport liquid used to fill the ink supply system from the printer, and ends in approximately 4 minutes.
9. When the transport liquid discharge sequence is completed, the message "Adj: Counter Clear" will be displayed in the LCD. When the [Enter] button is pressed, the message "Reset Counter?" will be displayed in the LCD. By pressing the [Enter] button, the counters for the following items will be reset. By executing this operation, initial filling will be done automatically when the power is turned ON next.
 - Ink cartridge consumption counter
 - Waste ink pad counter
 - Initial filling flag set
10. Turn the printer's power OFF, then pull the AC plug out of the AC outlet.

CONVERSION KIT PARTS REPLACEMENT PROCEDURE

1. 1. Open the front cover and take out the 2 screws (CP(W2) M3 x 6) holding the maintenance cover, then remove the maintenance cover.

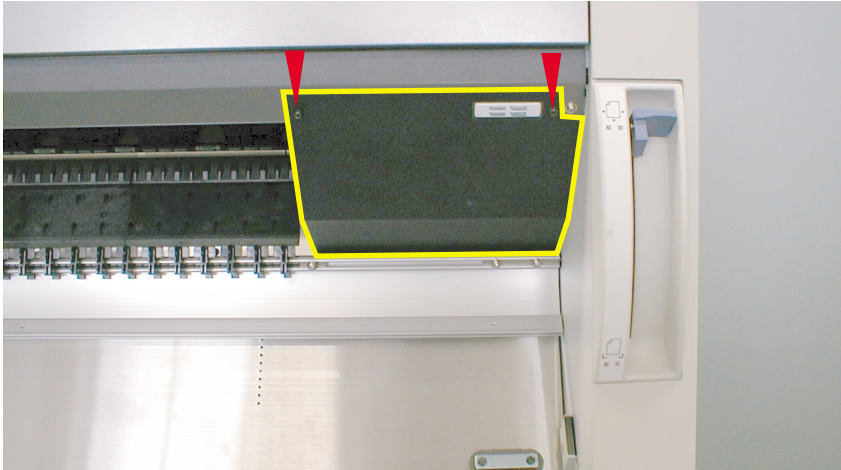

Figure 4-70. Removing the Maintenance Cover

2. 2. Take out the 4 screws (CP(W2) M3 x 6; 2 pcs., CP(W2) M4 x 6; 2 pcs.) holding the H top cover, then remove the H top cover.

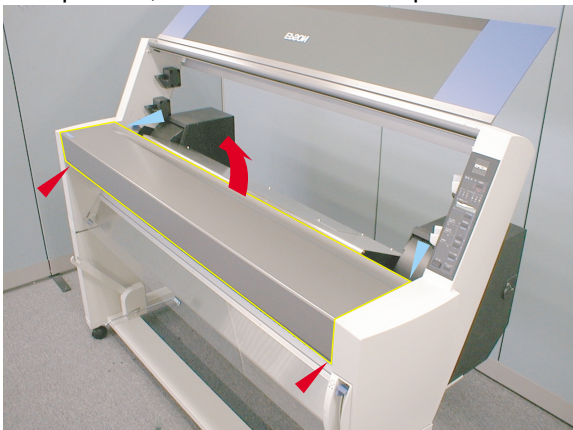

Figure 4-71. Removing the H Top Cover

3. 3. Take out the 7 screws (CP(W2) M4 x 12) holding the right side cover, then remove the right side cover. At this time, carefully pull out the panel FFC from the control panel that is incorporated into the right side.

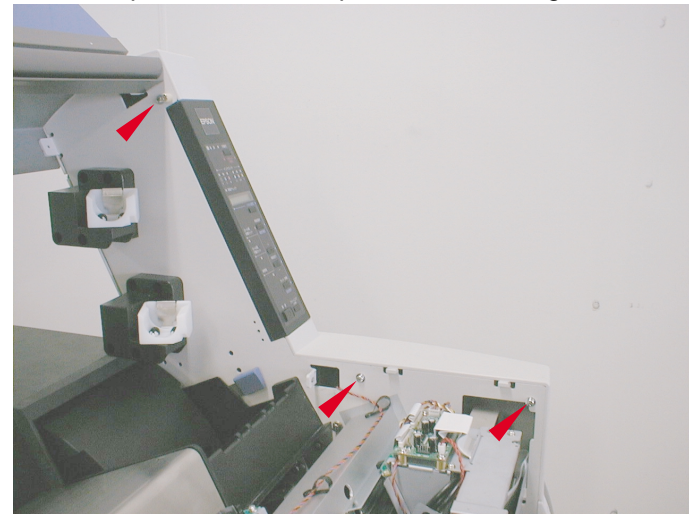

Figure 4-72. Removing the Right Side Frame

4. Take out the one screw that is holding the right cover holder assembly, then remove the right cover holder assembly.



Figure 4-73. Removing the Right Cover Holder Assembly

5. Pull the paper eject guide out from the paper support L.

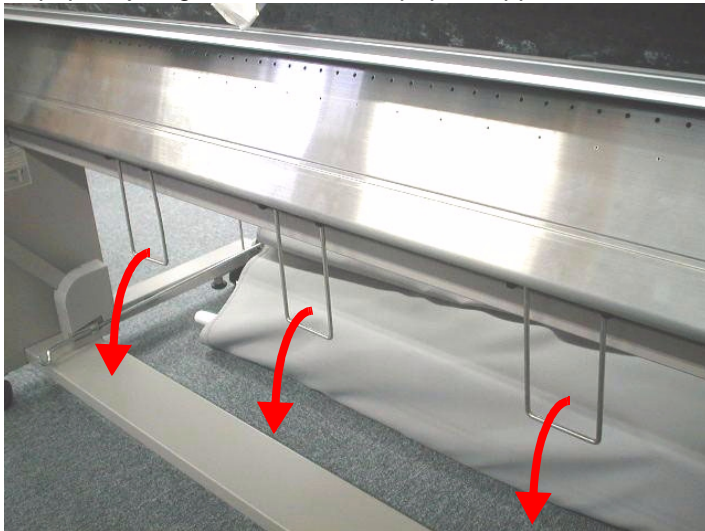

Figure 4-74. Removing the Paper Eject Guide.

6. Take out the 9 screws holding paper guide L, then carefully pull the paper guide L down and off the printer.



Figure 4-75. Removing the Paper Guide L (1)

7. Close the front cover (fasten it with adhesive tape, etc.), then pull the paper guide L completely off the printer in the downward direction.

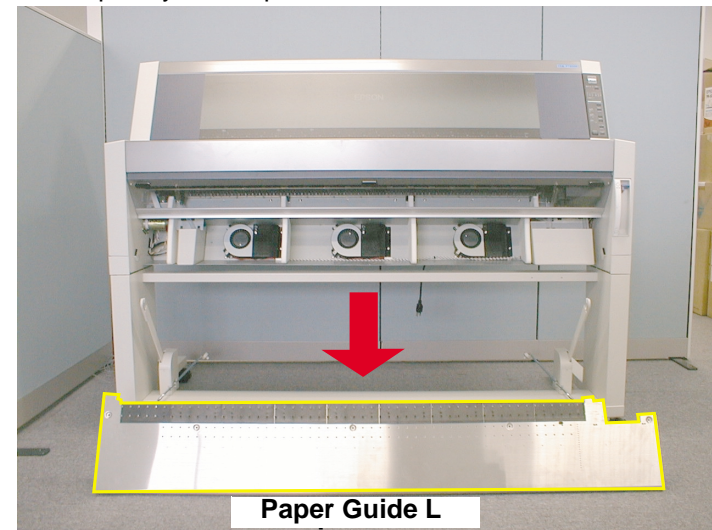

Figure 4-76. Removing the Paper Guide L (2)

CHECK
POINT

- When the paper guide L is removed, it becomes possible to perform the following removal procedures more smoothly.
1. Push the bottom end portion of the paper guide L toward the rear, then let the front part of paper guide L float free toward the front of the printer.
 2. Pull paper guide L gradually out and downward.
 3. First, pull out the right side of paper guide L, then pull it out toward the front of the printer. After that, pull the left side of paper guide L out toward the front of the printer.
- When assembling the paper guide L, assemble it following the above procedure in reverse order.

8. Take out the one screw holding the right F box, then remove the right F box.

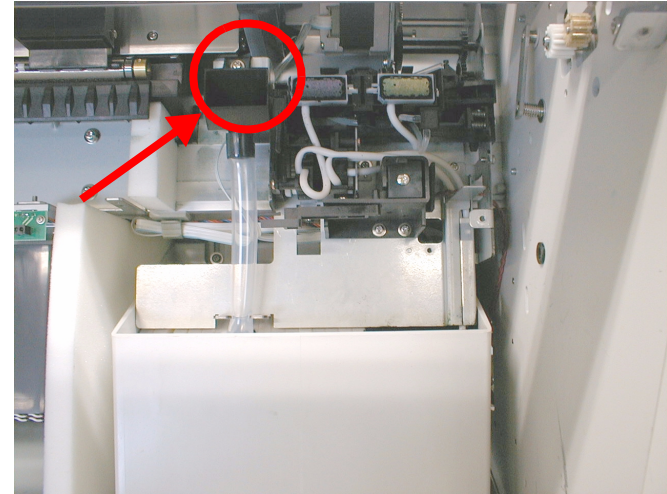

Figure 4-77. Removing the Right F Box

9. Take out the 2 screws holding the right waste ink pad box, then pull the right waste ink pad box out.

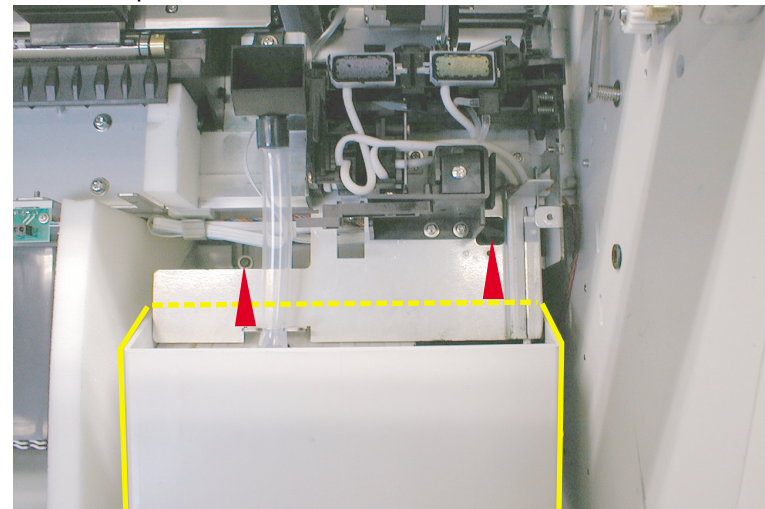

Figure 4-78. Removing the Right Waste Ink Pad Box

10. Take out the 2 screws holding the left F box, then take out the left F box. The screws holding the left F box are positioned at the back side of the left F box as shown in the figure below.

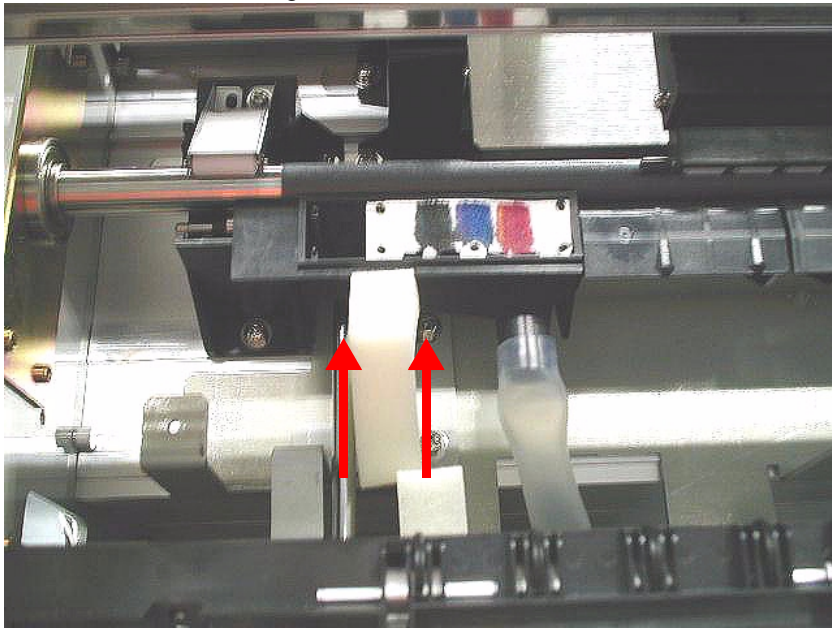
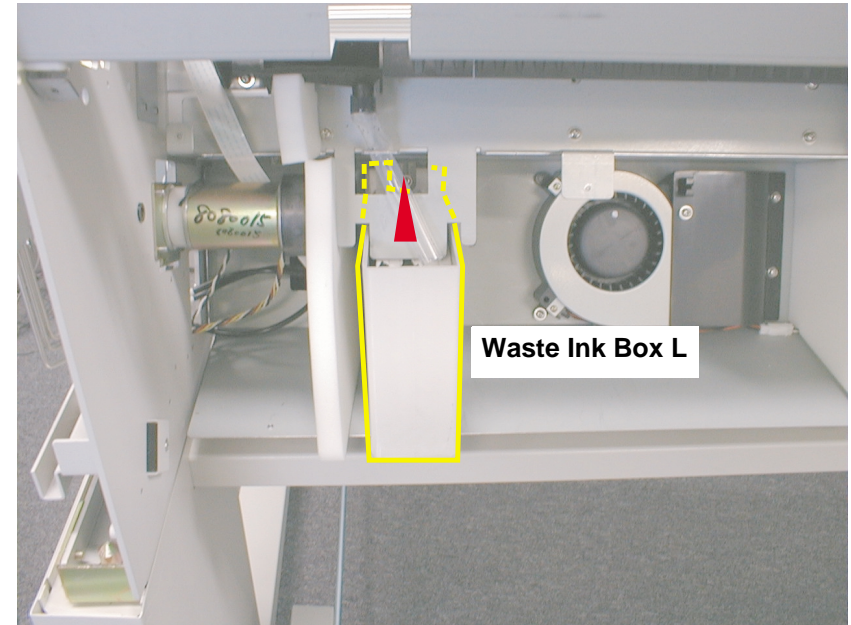

Figure 4-79. Removing the Left F Box

11. Take out the 1 screw (CP(W2) M4 x 8) holding the left waste ink pad box, then remove the left waste ink pad box.



▶ Screw (CP (W2)M4x8)

Figure 4-80. Removing the Left Waste Ink Pad Box



When installing the left and right waste ink pad boxes, make sure that the F box tubes are set securely in the groove in the metal frame.

12. Wrap a piece of cotton or a rag around the front ends of the waste ink tubes that are run from the pump to prevent ink from leaking.



Figure 4-81. Preventing the Leakage of Ink from the Waste Ink Tubes

13. Remove the waste ink pads from the conversion kit and replace the waste ink pads in the left and right waste ink pad boxes with new ones.
- Right waste ink pad box: Replace a total of 27 pads.
 - Left waste ink pad box: Replace a total of 7 pads.

After replacing the pads, place the left and right waste ink pad boxes off to the side where they will not be in the way while the rest of the operation is being completed.



After replacing the waste ink pads with new ones, place the used pads in the plastic bag where the new pads were packed, return it to the service center and dispose of it properly.

14. Pull the CR lock cable out of the CN9 connector on the relay board on the right side of the printer.

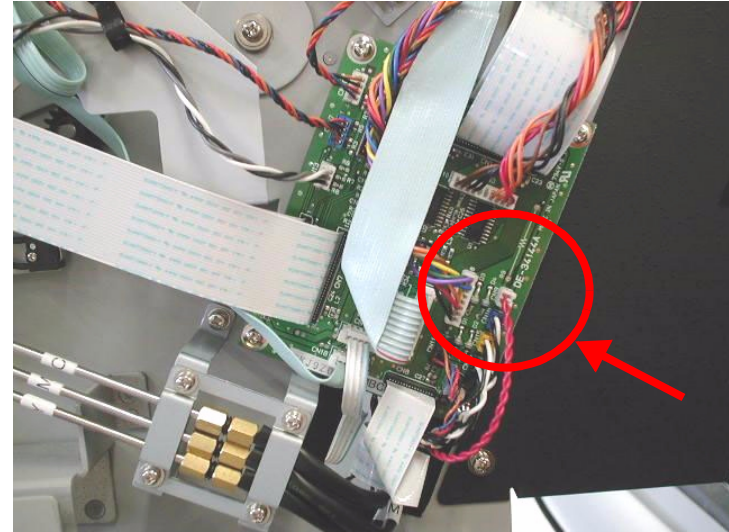

Figure 4-82. Removing the CN9 Connector Cable

15. Release the CR lock lever manually and move the CR unit from the capping position.



Figure 4-83. Releasing the CR Lock Lever

16. Take out the 3 screws (CP(W2) M4 x 6; 2 pcs., CP(W2) M3 x 6; 1 pc.) holding the maintenance assembly (cap assembly, pump assembly, pump motor, CR lock solenoid), then pull the maintenance assembly out gradually toward the front of the printer. Two of the screws holding the maintenance assembly are located on the back side of the maintenance assembly, as shown in the figure below.

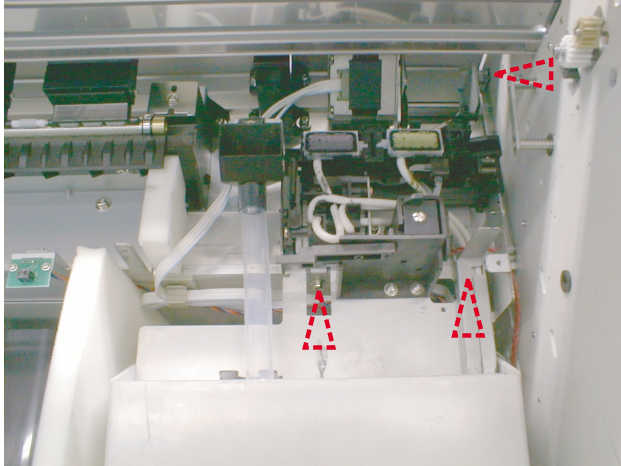

Figure 4-84. Removing the Maintenance Assembly (1)

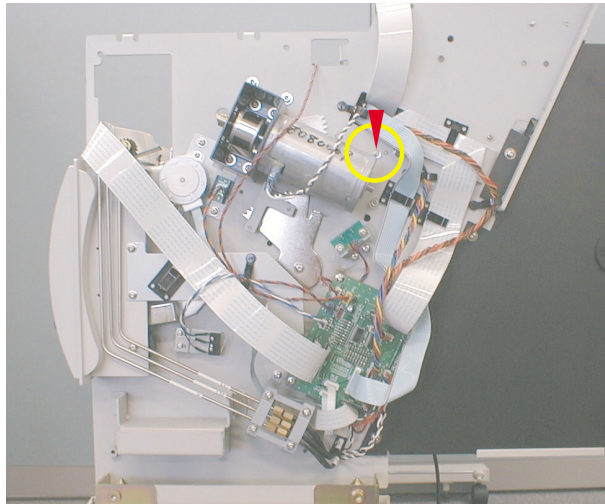

Figure 4-85. Removing the Maintenance Assembly (2)

17. If the maintenance assembly is gradually pulled out of the printer mechanism, the pump motor on the maintenance assembly will catch on the bottom of the front cover, so at this point, rotate the maintenance assembly clockwise as shown in the figure below then pull the maintenance assembly out. At this time, the front cover should be closed and fastened in place with adhesive tape.

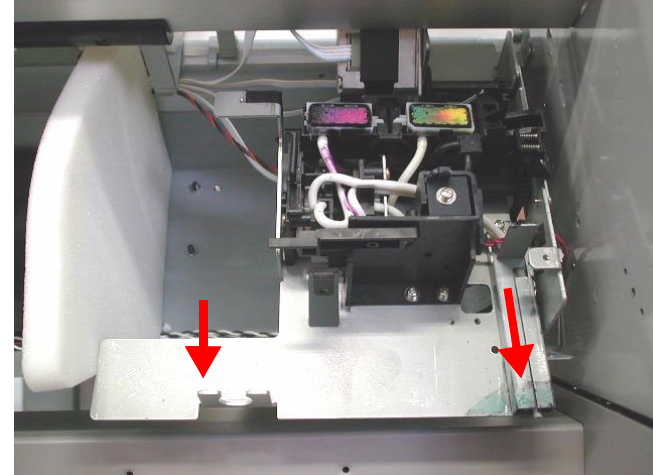

Figure 4-86. Removing the Maintenance Assembly (3)

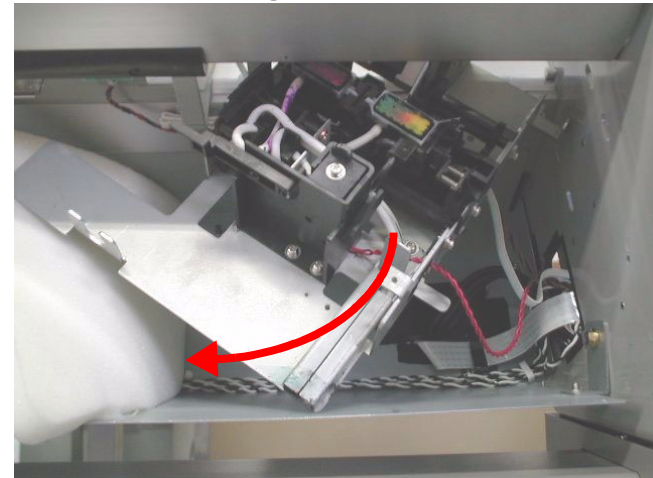

Figure 4-87. Removing the Maintenance Assembly (4)

18. Take out the one screw holding the cap assembly on the maintenance assembly that has just been pulled out, then disconnect the 2 waste ink tubes from the cap assembly and remove the cap assembly.
19. Take out the 2 screws holding the side frame on the maintenance assembly, then remove the side frame and reduction gear.

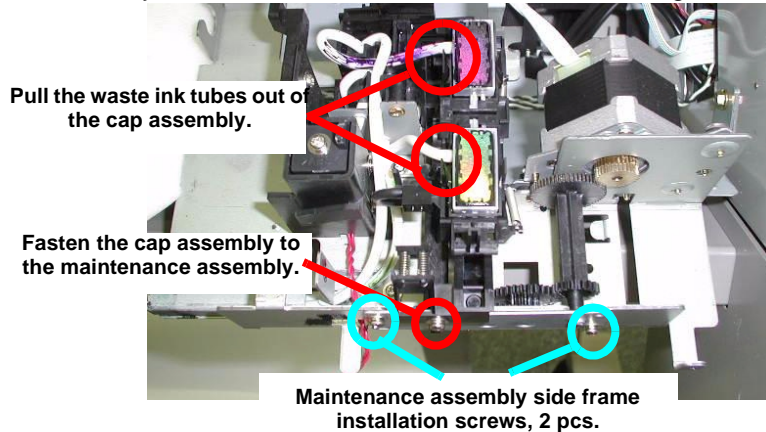

Figure 4-88. Removing the Cap Assembly

20. Take out the one screw holding the pump assembly, then remove the pump assembly from the maintenance assembly.

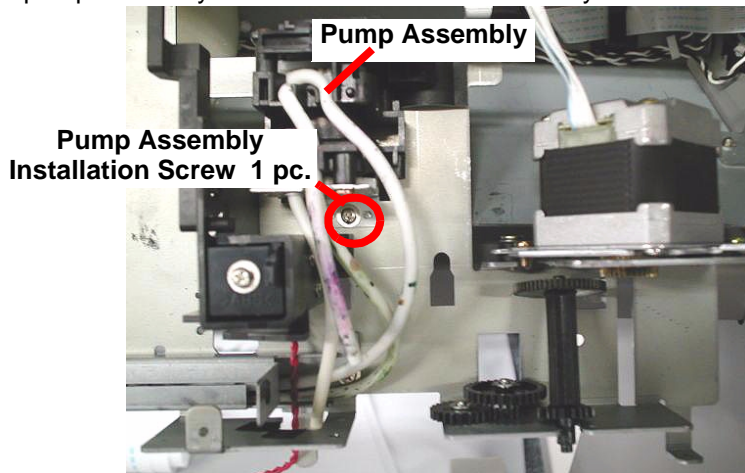

Figure 4-89. Removing the Pump Assembly

21. Take the pump assembly out of the conversion kit and assemble the head cleaner with tweezers.



- Adequate caution should be used when handling the head cleaner. Bare hands should not be used.
- When assembling the head cleaner, it should be assembled so that the felt part of the head cleaner is on the pump's right side and the rubber part is on the pump's left side, as shown in the figure below.

NOTE: When assembling the head cleaner, it should be assembled so that the felt part of the head cleaner is on the pump's right side and the rubber part is on the pump's left side, as shown in the figure below.

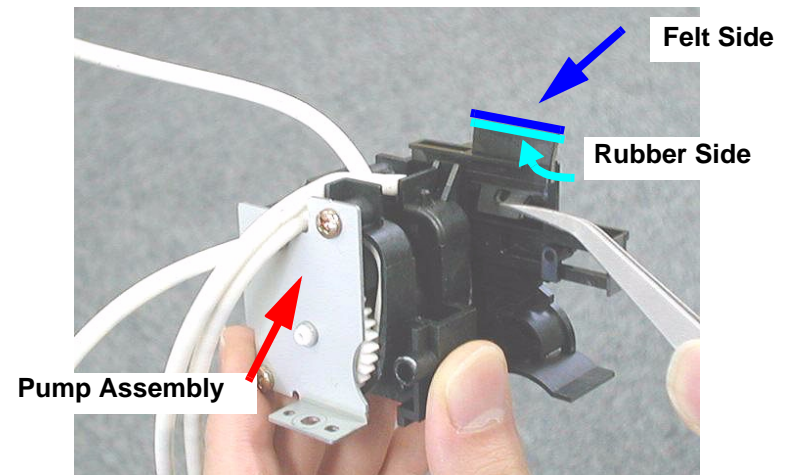

Figure 4-90. Fig. 4-90 Assembling the Head Cleaner

22. Assemble the new pump assembly (1 screw) and side frame (2 screws), the cap assembly (1 screw) and maintenance assembly following the procedure in steps 18, 19 and 20 in reverse order.
23. Assemble the maintenance assembly in the printer. (3 screws)
24. Insert CN9 in the relay board's connector.
25. Assemble the right waste ink pad box (2 screws), with the pads replaced with new ones, in the printer.

26. Assemble the left waste ink pad box (1 screw), with the pads replaced with new ones, in the printer.

**CHECK
POINT**

When assembling the right waste ink pad box, first, set the screws in the screw grooves in the waste ink pad box, then carefully push the box into position. After that, tighten the screws to fasten the box in place.

27. Take the left and right F boxes from the conversion kit and assemble them in the printer (1 screw each).

**CHECK
POINT**

- Make sure the waste ink tubes of the pump assembly are routed securely around the right side of the maintenance assembly.
- Make sure the waste ink tube to the right F box is fitted securely to the tube attachment position on the maintenance assembly.
- Make sure the waste ink tube to the left F box is fitted securely to the mechanism frame.
- Make sure the pump motor cable is run correctly.

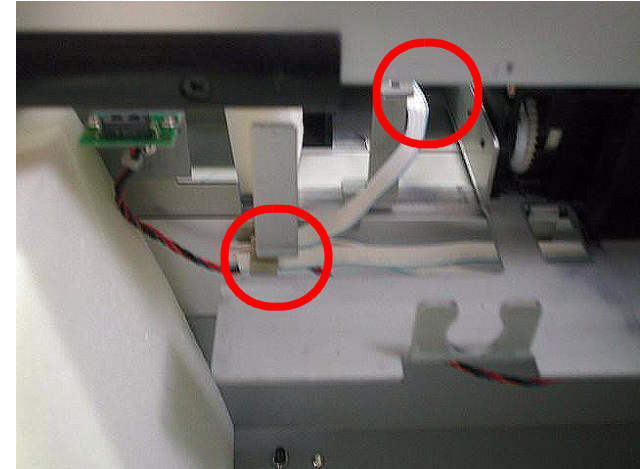
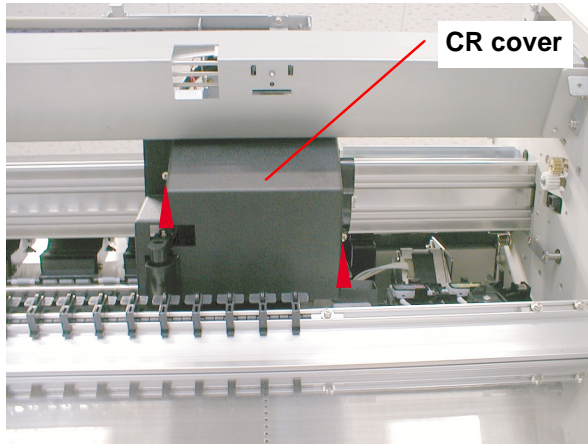

Figure 4-91. Running the Pump Motor Cable

- Make sure the connector for the CR lock solenoid is inserted in the CN9 connector on the relay board.

28. Assemble the paper guide L (9 screws) and right cover holder (1 screw) in the printer.

29. Take out the 2 screws holding the CR cover, then remove the CR cover



▶
Figure 4-92. Removing the CR Cover

30. Take out the one screw holding the damper holder on the CR unit, then disconnect the 6 ink tubes from the damper holder. Slide the damper holder to the right side and remove it.

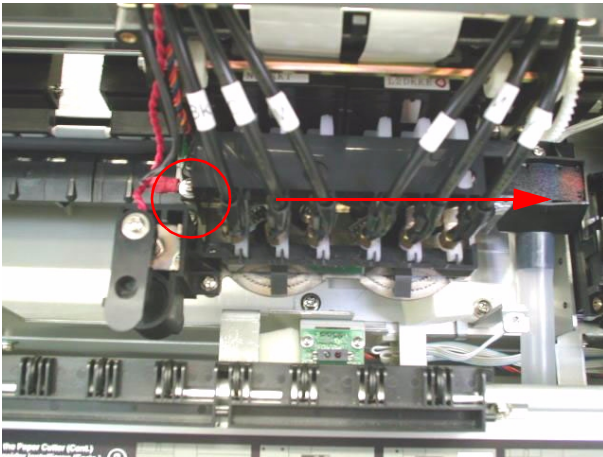

Figure 4-93. Removing the Damper Holder

31. Pull out the 6 dampers from the print heads carefully, wrapping each one in a soft piece of cloth, etc. to prevent transport liquid from leaking out.



Figure 4-94. Removing the Dampers

32. Loosen the hex nuts used to fasten the ink tubes to the dampers, then remove them.
33. Take off the ink tubes, and remove the O-rings from inside the hex nuts.

34. Take the 6 O-rings from the conversion kit and install them on the ink tubes as shown in the figure below.



- When installing the O-rings, take adequate care in handling, and do not touch them with bare hands.
- When installing the O-rings on the ends of the ink tubes, use the following procedure.
 1. Put on a finger sack or wear a rubber glove which has no adhesives on the surface.
 2. Wet the O-ring with S46 transport liquid from the end of the ink tube or from the old dampers.
 3. Pass the O-ring onto the ink tube.

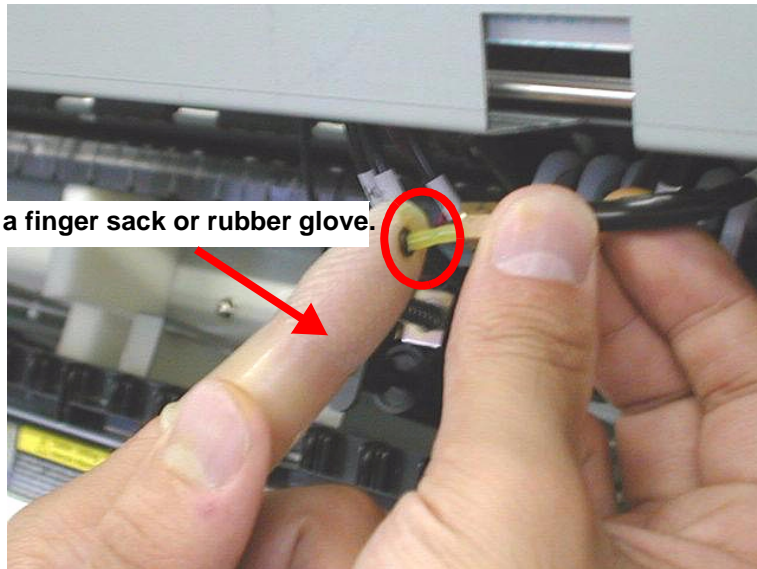

Figure 4-95. Installing the O-rings

35. Take the 6 new hex nuts and dampers from the conversion kit, insert each of the ink tubes with an O-ring fitted on it through a hex nut, then set the dampers on the side opposite the hex nuts. After that, tighten the 6 hex

nuts using the exclusive torque wrench, Tool No. #F760. If the hex nuts are tightened with a torque exceeding the standard torque, the front end of the wrench spreads and prevents over torque.

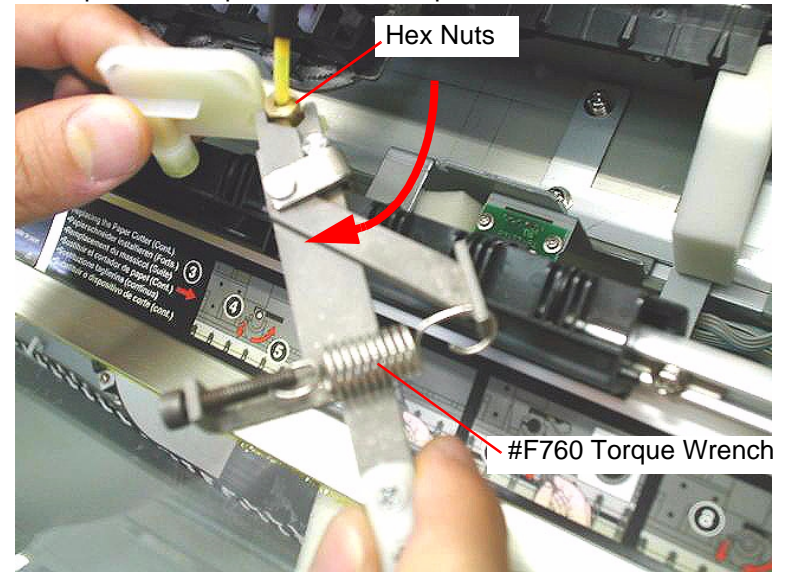

Figure 4-96. Tightening the Hex Nuts



CAUTION If the hex nuts are tightened at a torque exceeding the standard torque, it deforms the O-rings and causes ink to leak or causes air bubbles to get mixed into the ink. The specified torque wrench should be used.

36. Insert each damper into the ink supply port in the print heads, then assemble the damper holder. (1 screw)
37. Set each ink tube in the damper holder, then assemble the CR cover. (2 screws)
38. Assemble the right side cover (7 screws) and H top cover (4 screws).
39. Assemble the maintenance cover (2 screws).

AFFIXING LABELS

1. Affix the following labels in the specified locations.

■ EPSON _COLOR FAST Label

Affix this label on the right front of the H top cover.

■ Manual Cutter Cutting Position Labels

Horizontal Position: Align the scissors cutting line on the label with a position 10 cm down from the bottom edge of the sub-platen.

Vertical Position: Align the label along the same line as the sub-platen's right edge.

■ Right Ink Cartridge Model No. Label

Affix the right ink cartridge Model No. label over top the dye based ink label.

■ Left Ink Cartridge Model No. Label

Affix the left ink cartridge Model No. label over top the dye based ink label.

For details, see the figure below.

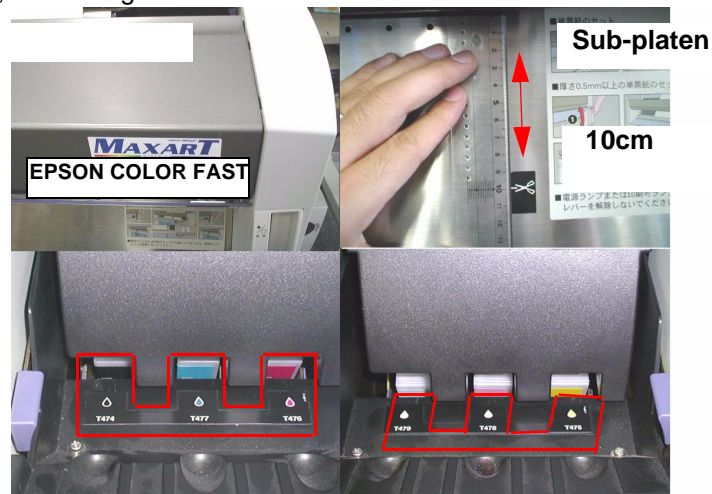

Figure 4-97. Label Affixing Positions

PIGMENT INK INITIAL FILLING

1. Take the 6 pigment ink cartridges from the conversion kit and set them in the I/H holders. Lower the ink lever securely.
2. Insert the AC cable in the outlet.
3. When the printer's power switch is turned on, the initial filling sequence will start automatically. Approximately 7 minutes is necessary to complete this sequence. The main initial filling flag starts based on the flag set in the "Ink Discharge Procedure" on page 124.

UPLOADING PIGMENT INK FIRMWARE

1. The printer's firmware should be updated to the firmware for pigment ink using the exclusively stipulated PC card or via the parallel interface cable.

CAUTION



- **Whichever method is used, a PC card or the parallel interface cable, if the power is turned off during the firmware update process, this procedure should be repeated from the beginning.**
- **If you are updating the firmware via a PC card, the following PC card should be used.**
Tool No.: #F727 Flash Memory
ASP Code: 1050073
- **If you are updating the firmware via a PC card, it should be used after writing data using the following utility.**
ADTEC System Science Card Utility 97
- **If you are writing firmware via the parallel interface cable, it should not be used in the ECP mode. The compatible mode should be used.**
- **The firmware file extension will differ as follows depending on the means used to write the firmware, so it should be used so as to be incorporated correctly.**
Via the PC: V0XX0X. ipl
Via a PC Card: V0XX0X. rom
Note): The "X" differs depending on the version.

□ Uploading via the Parallel Interface

1. Turn the printer's power Off.
2. Make sure the BIOS setting of the PC you are using is not the ECP mode setting. This operation runs only in the compatible mode.
3. Start the firmware upload mode by turning the Power switch On while pressing the following buttons. In this mode, the yellow ink LED will light up and "Data Transfer" will be displayed in the LCD.
 - Paper Source button + Cut / Eject button + Cleaning button
4. Input the following at the PC's DOS prompt, then press the ENTER key to transfer the firmware data.
 - COPY _/B_file name.ipl_LPT1:
5. If the firmware update is run correctly, the following messages will be displayed in order in the LCD. During this time, all the ink LED's on the panel will blink repeatedly. This operation will be completed in approximately 2 minutes.
 - Data Send _ Flash Erase _ Flash Write _ Complete _ Program Load End
6. When the above LCD display ends, turn the printer's power switch Off.

□ Uploading via a PC Card

1. Turn the printer's power Off.
2. Remove the access cover on the top paper guide, then insert a PC card with the date already written to it in the PC card slot on the main board.
3. Turn the printer's power On.
4. The printer will start uploading the firmware automatically, and the following messages will be displayed in order in the LCD. During this time, all the ink LED's on the panel will blink repeatedly.
This operation will be completed in approximately 2 minutes.
 - Copy 1 _ Copy 2 _ Copy 3 _ Copy 4 _ Copy 5 _ Copy 6 _ Copy 7 _ Compare 1 _ Compare 2_ Compare 3 _ Compare 4 _ Compare 5 _ Compare 6 _ Compare 7 _ End
5. When the above LCD display ends, turn the printer's power switch off, then take the PC card out of the slot.

NOZZLE CHECK & FIRMWARE VERSION CONFIRMATION

1. Set roll paper in the printer, then lower the paper set lever securely.
 1. Turn on the power switch while pressing the following buttons and start the Self-diagnostic mode.
 - Paper Feed – Button + Cut / Eject Button + Cleaning Button
 2. Press the [Paper Source] button and select "Check: Print," then press the [Enter] button.
 3. Select "Print: Nozzle Check" by pressing the [Paper Source] button, then press the [Enter] button and print the nozzle check patter. The following items are printed out in this nozzle check pattern printout.
 - Nozzle Check Pattern
 - Firmware Version
 - Waste Ink Pad Counter
 4. Check the following contents in the printed out nozzle check pattern.
 - Check if all the nozzles are spraying ink correctly by the nozzle check pattern.
 - Check if the firmware version is correctly updated to the pigment ink version.
 5. If missing of dots is confirmed, press the [Pause] button, the return to the Self-diagnostic mode's starting menu and select "Check: Cleaning". Conduct cleaning, selecting Cleaning KK1, kk2 or Initial filling in accordance with the level of dot missing.
- NOTE:** *If all the nozzles are causing missing of dots, check the cap's waste fluid tubes, and also recheck the joints to the head dampers and ink supply tubes.*
6. If the firmware version has not been updated to the pigment version, Carry out pigment firmware uploading again, according to the preceding pate.

4.2.4.6 Required Adjustment Items

After assembling the component parts in the conversion kit and updating the firmware, the following adjustments should be made.

Table 4-8. Adjustment Items

Adjustment Item		Required Jigs
1	Paper Guide L Assembly Position Adjustment	#F755
2	Cutter Position Adjustment	#F756
3	Paper Cutting Position Check	Gauge
4	CR Cover Installation Position Adjustment	#F724
5	Bi-D Adjustment	Since this adjustment is carried out from the panel, an exclusive tool is not required. However, concerning pattern #4, use the adjustment value check pattern.
6	Head Gap Adjustment	Since this adjustment is carried out from the panel, an exclusive tool is not required.
7	P_FRONT / REAR / EDGE Adjustment	#F751 Micro Tracing Paper

NOTE: Concerning the #4 check adjustment pattern in the Bi-D adjustments, This is a file for checking the adjustment results by actually printing out the adjustment values.



Each adjustment should be carried out in the order shown in the above table. In particular, the adjustment sequence must be strictly observed for the adjustment items in No. 1 ~ No. 3. If other adjustments in the sequence are carried out first, the cutter position will not be adjustment accurately.

PAPER GUIDE L ASSEMBLY POSITION ADJUSTMENT

This adjustment is carried out for the following purposes.

- To install paper guide L so that it is parallel with the PF roller.
- To adjust paper cutting position's accuracy roughly with respect to the cutter level difference on the sub-platen.

1. Loosen the 9 screws holding paper guide L, then set tool No. #F755 between the paper guide L on the printer's left side and the platen. While pushing paper guide L toward the sub-platen (up direction), tighten the 4 screws that fasten the left side of the paper guide L.

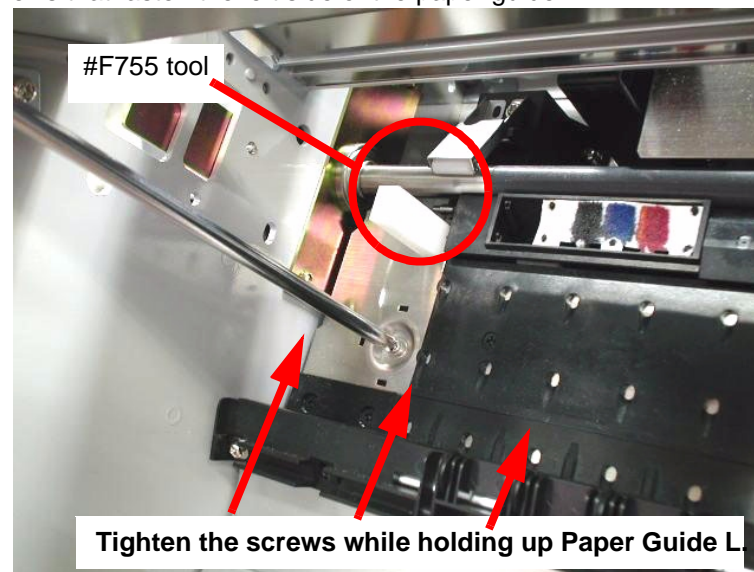

Figure 4-98. Adjusting the Paper Guide L Assembly Position (1/2)

- While supporting the paper guide L with one hand, set tool No. #F755 between the paper guide L on the printer's right side and the platen as shown in the figure below. While pushing up the paper guide L in the direction of the sub-platen (upward), tighten the 5 screws used to the fasten the right side of the paper guide L.

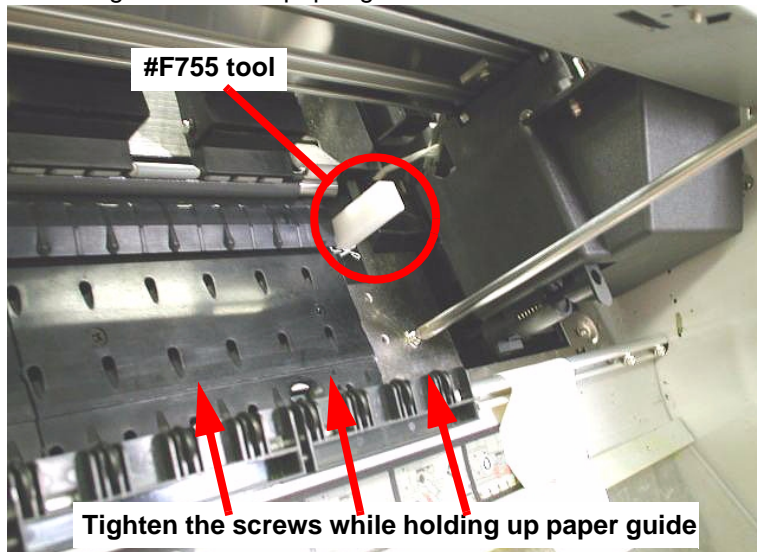

Figure 4-99. Adjusting the Paper Guide L Assembly Position (2/2)

- Again, set the tool, No. #F755 between the paper guide L on the printer's left side and the platen, then make sure that the tool cannot be inserted smoothly. If it is possible to insert the tool smoothly, adjust the paper guide L assembly position on the left side again.



The criterion of this adjustment is to adjust the paper guide L assembly position so that when the tool, No. #F755, is inserted and pulled out from between the paper guide L and the platen, somewhat of a load is felt.

CUTTER POSITION ADJUSTMENT

This adjustment is performed for the following purposes.

- To assemble the cutter assembly so that it is parallel to the cutter groove position on the sub-platen on paper guide L.
- To assemble the cutter assembly in the correct position with respect to the cutter groove position on the sub-platen on paper guide L.

- Take out the 2 screws holding the CR Cover, then remove the CR cover.
- Insert the projections on tool # 759 in the row of holes in the 2nd level of the sub-platen on the right side of the sub-platen, installing the tool.

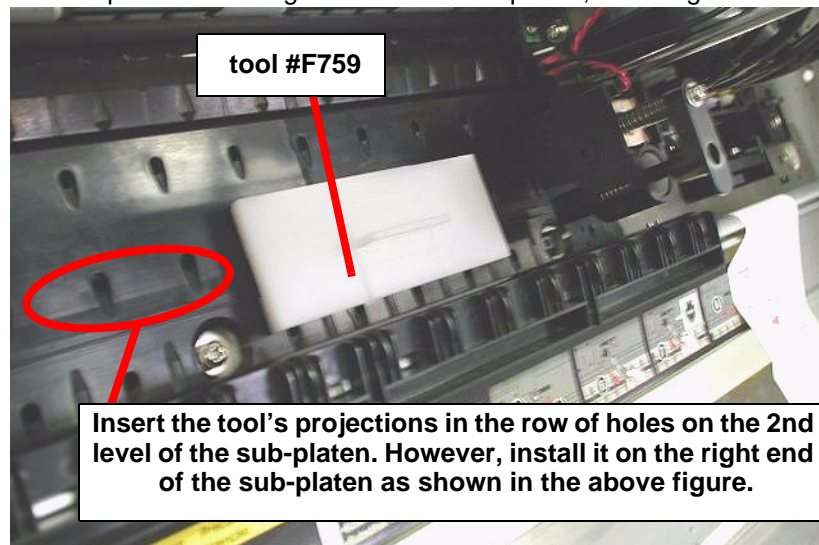

Figure 4-100. Assembling tool #F759.



- The projections on tool No. #F759 should be inserted securely in the row of holes on the 2nd level of the sub-platen.
- The three notches in tool No. #F759 should fit the ribs on the sub-platen.

3. Move the CR unit so as to cover tool No. #F759, set on the sub-platen. At this time, the rib on the tool should pass between the cutter assembly and solenoid.
4. Loosen the 2 screws holding the cutter solenoid and cutter assembly then push the cutter assembly to the rib on the tool.

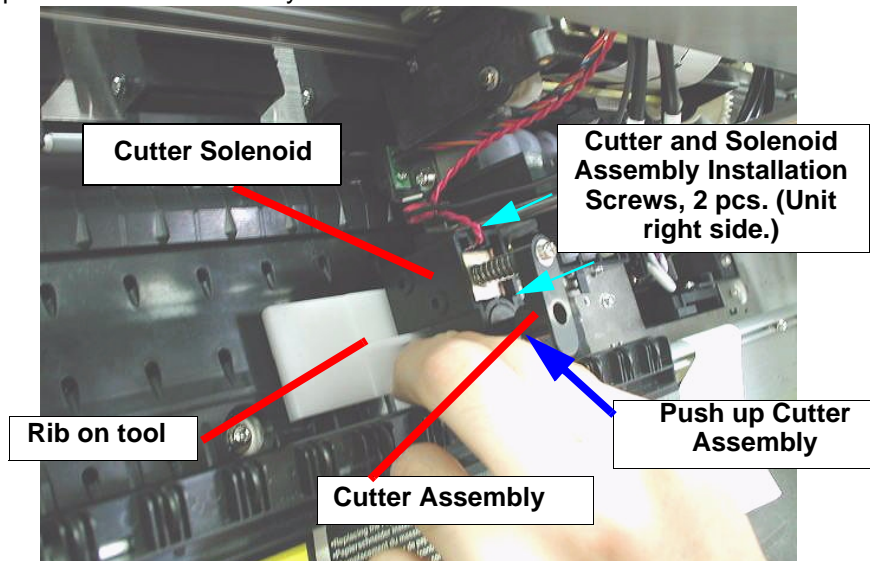

Figure 4-101. Cutter Position Adjustment

5. Tighten the 2 screws holding the cutter solenoid and cutter assembly.

PAPER CUTTING POSITION CHECK

This check operation, by actually cutting paper, checks the following adjustment results of the adjustment which was carried out previously, which determine the paper cutting position.

- Paper Guide L Assembly Position Adjustment
 - Cutter Positioning Adjustment
1. Set paper (minimum size: 10 cm wide x 20 cm) in the paper path along the paper setting position on the right side of the printer, then move the paper set lever back and set the paper.
 2. Move the CR manually to the right edge of the paper, then lower the cutter manually.
 3. While holding the bottom edge of the paper with one hand, cut the paper with the cutter.
 4. Set a gauge with minimum measuring units of 0.5 mm at the edge of the cutter level difference on the sub-platen and check if the distance from the edge of the cutter level difference to the actual paper cutting position is within 0.5 mm \pm 0.2 mm.

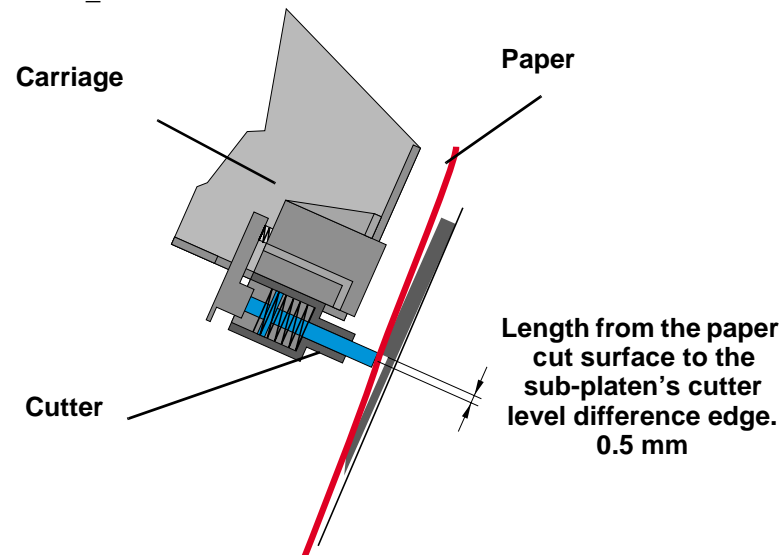

Figure 4-102. Checking the Paper Cutting Position

5. If the measuring results are outside the standard, loosen about 2 of the screws holding the paper guide L, then carry out fine adjustment of the paper guide L's assembly position.



- **The length from the edge of the cutter level difference to the front edge of the paper where it was actually cut should be within 0.5 mm _ 0.2 mm.**
 - **If you are adjusting the assembly position of the paper guide L, the installation screws that are loosened should be the absolute minimum number of screws necessary to adjust the position. If a large number of screws is loosened, the assembly position of the paper guide L will shift a great distance from the original adjustment position, so caution should be exercised.**
6. In the same way, set paper on the left side of the printer, cut the paper manually and measure the length from the cutter level difference to the front edge of the paper. If the measurement results are not within the standard, loosen about 2 of the screws holding the paper guide L and carry out fine adjustment of the paper guide L's assembly position.

CR COVER HEIGHT ADJUSTMENT

This adjustment is performed for the following purpose.

- The cutter's operating stroke is restricted by the CR cover's assembly position, so this adjustment adjusts the CR cover's assembly position so that it will be proper.

1. Tighten 2 installation screws in the CR cover on the CR unit temporarily.
2. Set tool No. #F724 on the sub-platen in the following position. Set it on the installation screw which is second from the right on the sub-platen.

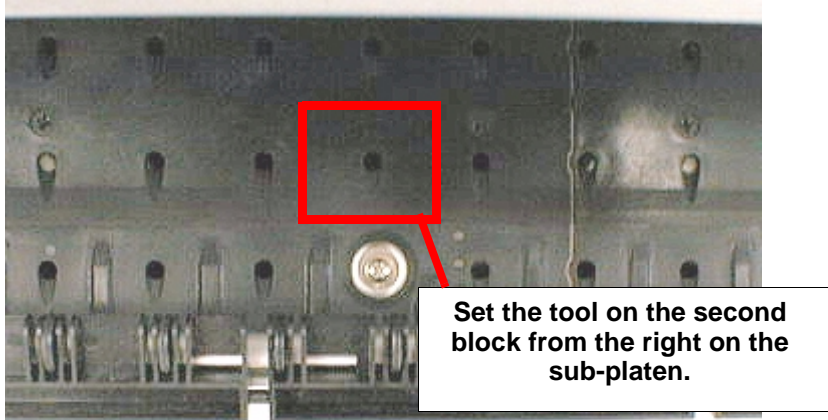

Figure 4-103. CR Cover Height Adjustment tool Setting Position

3. Move the CR unit manually over the tool and set the cutter holder in the groove on the tool shown in the figure at left. At this time, check if the tool is securely in contact with the sub-platen.



- As shown in the figure at right, there is no problem even if the tool's level difference and the sub-platen's level difference do not coincide perfectly.
- If the tool fits snugly against the lower level surface of the sub-platen, there is no problem

4. Tighten the CR cover installation screws while lightly pushing the CR cover toward the sub-platen.

5. Move the CR to the carriage position.

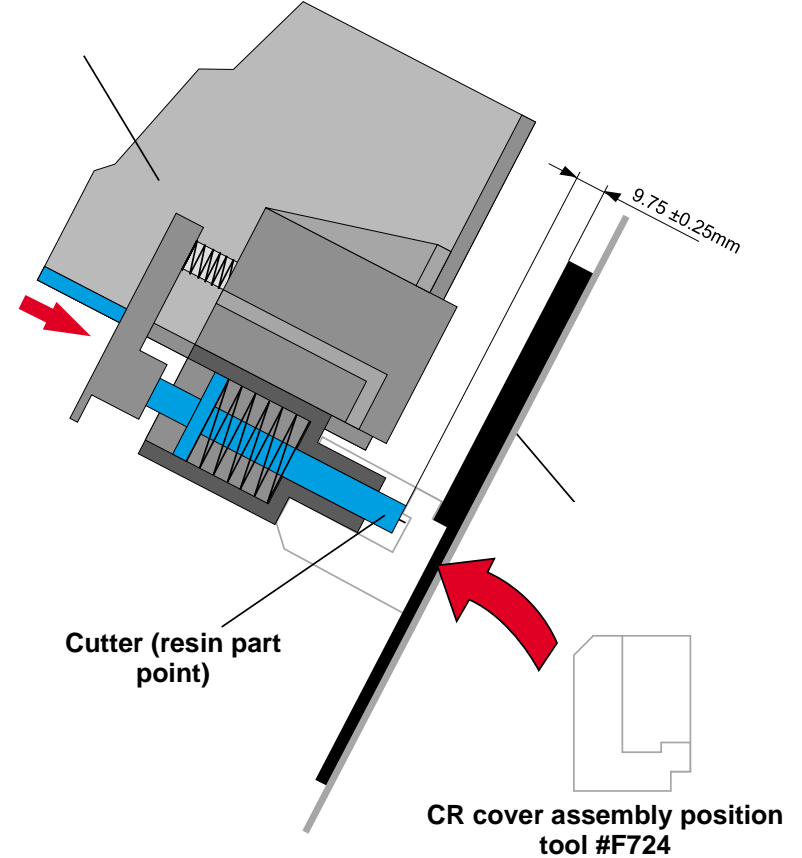

Figure 4-104. CR Cover Height Adjustment

BI-D ADJUSTMENT

This adjustment is performed for the following purpose.

- Together with the updating of the new firmware (for pigment ink), the Bi-D adjustment printing modes have been changed, so it is necessary to make new adjustments.

The following 4 adjustment items are adjusted in the Bi-D adjustment in the pigment ink firmware.

Table 4-9. Bi-D Adjustment Items

Item	Contents	No.
BiD/200/M/B	Bi-D Adjustment / 240 cps / Normal-dot / B head	#1
BiD/200/M/C	Bi-D Adjustment / 240 cps / Normal-dot / C head	#2
BiD/300/N/B	Bi-D Adjustment / 333 cps / Normal-dot / B head	#3
BiD/300/N/C	Bi-D Adjustment / 333 cps / Normal-dot / C head	#4

NOTE: NOTE: The numbers in the above table show the number of the printing adjustment pattern printed out initially when printing the adjustment patterns.

1. Turn the printer's power On while pressing the following buttons to start the Self-diagnostic Mode.
 - Paper Feed – button + Paper Feed + button + Cut / Eject button
2. Press the [Paper Source] button to select "Check: Adjustment," then press the [Enter] button.
3. Press the [Paper Source] button to select "Adj: Bi-d", then press the [Enter] button.
4. The message "Pattern printing" will be displayed in the LCD and the Bi-D adjustment patterns will be printed out.
5. When printing of all 4 Bi-D adjustment pattern items is completed, the message "BI-D, 200. M. B: XXX" will be displayed in the LCD.
6. Check printing pattern No. 1 to No. 3, confirming if the vertical lines in the first pass deviate from the vertical lines printed in the second pass.

- If there is no pattern deviation in printing patterns No. 1 to No. 3, press the [Paper Source] button 3 times and proceed to the printing pattern No. 4 adjustment menu. (Proceed to Step 8.) Confirm that "Bi-D, 300. N. C" is displayed in the LCD.
- If there is pattern deviation in printing patterns No. 1 to No. 3, press the [Paper Source] button several times to proceed to the adjustment menu for the affected pattern, then press the [Paper Feed + or –] button to input the appropriate numerical value. After inputting the correction value, press the [Enter] button. The printer will then print out the pattern with the results of the input correction value. The relationship between the inputs using the [Paper Feed + or –] button and the printing results is as shown below.

- Adjustment Value Minimum Resolution: 1/2880 inch
- Correction Direction: Paper Feed – button = Moves the line on the 2nd pass toward the HP side.
Paper Feed + button = Moves the line on the 2nd pass away from the HP.
- Adjustment Target: There should be no deviation between the lines on the first pass and the lines on the 2nd pass.

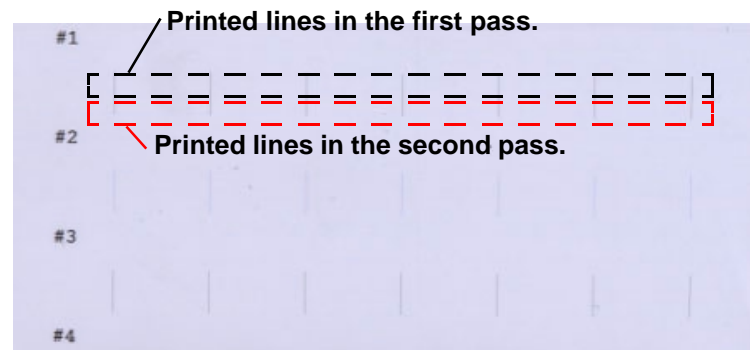

Figure 4-105. Bi-D Adjustment Pattern No. 1 ~ No. 3.

7. Repeat the above step 6 in order to carry out the adjustment of Bi-D printing patterns No. 1 to No. 3.

8. Select “ND Base Value Adjust xx” by pressing the [Paper Source] Button. Check the results of printing Bi-D adjustment pattern No. 4 and check whether the following patterns exist in the 8 patterns each of light cyan, light magenta and yellow. The pattern No. of each pattern is printed in hexadecimal notation beneath it.

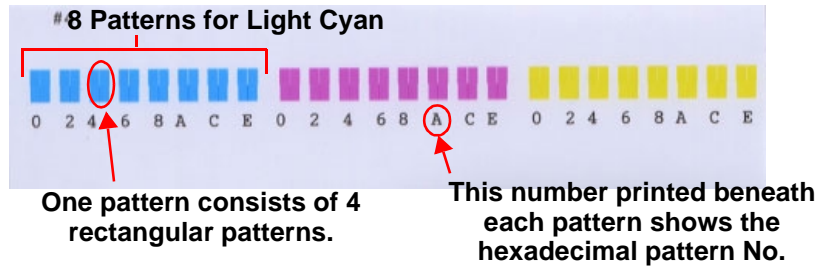

Figure 4-106. Bi-D Adjustment Pattern No. 4

- Each individual pattern consists of 4 rectangular patterns. Search for the pattern among the 8 patterns in each color where there is no gap and no overlapping between these 4 rectangles.

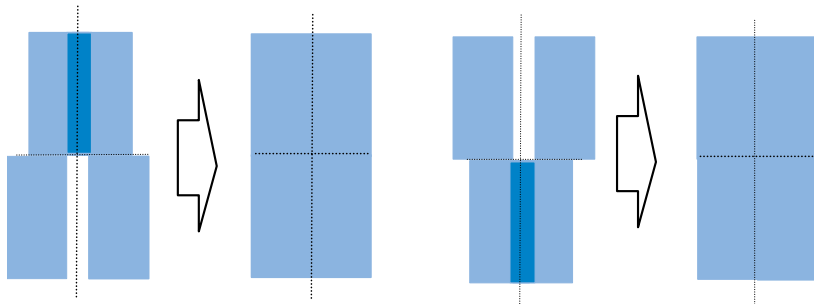

Figure 4-107. Bi-D Adjustment Pattern No. 4 Check Method

9. If you can confirm a pattern among the 8 patterns of each color where there is no gap and no overlapping between these 4 rectangles, press the Paper Source button and move to the adjustment menu for each color. Proceed to Step 11.
If you were unable to confirm an appropriate pattern among the 8 patterns printed in each color, use the Paper Feed + / – buttons to input an estimated value in the “ND Base Value Adjust xx” menu.

- Paper Feed + Button: Moves the top 2 out of the 4 patterns within the printed pattern in a direction so that they separate.
- Paper Feed – Button: Moves the bottom 2 out of the 4 patterns within the printed pattern in a direction so that they separate.

Input the estimated values in the “ND Base Value Adjust xx” Menu, then press the [Enter] button to print a new Bi-D No. 4 print pattern.

10. Repeat the above step 9 until the proper printing pattern can be confirmed.
11. “ND LC: XX” will be displayed in the LCD. In this menu, input the pattern No. of the pattern among the 8 light cyan printed patterns which was confirmed to be proper using the [Paper Feed + or –] buttons. The pattern No. on the printed pattern has the numbers printed in hexadecimal, with each number increased by 2 from the number of the pattern to its left, but in this menu, it is possible to input each of the 16 numbers in hexadecimal. After inputting a value, press the [Enter] button.
12. “ND LM: XX” will be displayed in the LCD. In this menu, input the pattern No. of the pattern among the 8 light cyan printed patterns which was confirmed to be proper using the [Paper Feed + or –] buttons. The pattern No. on the printed pattern has the numbers printed in hexadecimal, with each number increased by 2 from the number of the pattern to its left, but in this menu, it is possible to input each of the 16 numbers in hexadecimal. After inputting a value, press the [Enter] button.
13. “ND Y: XX” will be displayed in the LCD. In this menu, input the pattern No. of the pattern among the 8 light cyan printed patterns which was confirmed to be proper using the [Paper Feed + or –] buttons. The pattern No. on the printed pattern has the numbers printed in hexadecimal, with each number increased by 2 from the number of the pattern to its left, but in this menu, it is possible to input each of the 16 numbers in hexadecimal. After inputting a value, press the [Enter] button.
14. Make sure the message “Bi-D End” is displayed in the LCD, then move to the next adjustment item.



- Up to Bi-D adjustment patterns No. 1 ~ 3, by deciding the value input from the panel, the adjustment results are printed out, so it is possible to check the adjustment results visually, but for Bi-D adjustment pattern No. 4, even if you decide a value to input from the panel, a printing pattern that reflects the adjustment results is not printed, so the adjustment results cannot be checked visually. Therefore, if you are confirming the adjustment results for adjustment values by printing pattern, the following DOS program becomes necessary.

* Program Transfer Utility: Pout3.Exe

* Program Name: Bid333.prn

The program transfer method is as follows.

1. Confirm that the printer is in the Pause state.
2. Move to the DOS prompt.
3. Input "POUT__BID333.PRN."
4. Press the Enter key.

Through the above operation, a total of 9 blocks of printing patterns are printed out in each color. The results from the adjustment values input in the Adjustment mode are positioned in the center pattern of the 9-block pattern of each color.

Adjustment Results



HEAD GAP ADJUSTMENT (ALIGNMENT BETWEEN HEADS)

This adjustment is performed for the following purpose.

- The GAP adjustment printing mode has been changed together with the update to the new firmware (pigment ink), so a new adjustment is necessary.

The following 2 items related to the GAP adjustment in the pigment ink firmware are adjusted.

Table 4-10. Head Gap Adjustment Items

Item	Description	Number
Gap/200/M	Head GAP adjustment / 240 cps / Normal Dot	#5
Gap/300/N	Head GAP adjustment / 333 cps / Normal Dot	#6

NOTE: NOTE: The numbers in the above table are printed at the beginning of the printing pattern when the adjustment pattern is printed and show the adjustment pattern No.

1. After inputting the Bi-D adjustment, confirm that "Bi-D End" is displayed in the LCD. The program will move to the Head Gap adjustment mode, so press the [Enter] button.
2. Confirm that "Adj: Head LR Adj" is displayed in the LCD. Press the [Enter] button to print the adjustment pattern.

3. After all the adjustment patterns (#5, #6) are printed, "Gap, 200, M: XXX" will be displayed in the LCD.

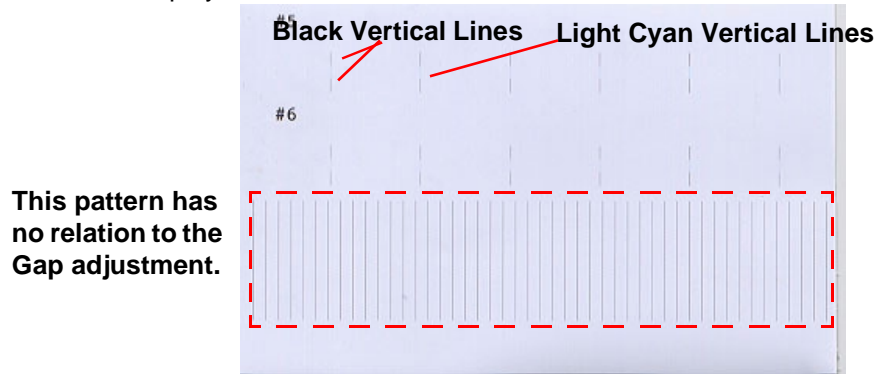

Figure 4-108. Head Gap Adjustment Pattern

4. Check printing patterns No. 5 and No. 6, and check for deviation of the black vertical lines in the 1st and 3rd pass and in the light cyan vertical lines in the 2nd pass.
- If there is no deviation in the patterns in printing patterns No. 5 and No. 6, press the [Paper Source] button 2 times, then check if the message "Gap End." is displayed in the LCD. Proceed to Step 6.
 - If there is deviation in the patterns in printing patterns No. 5 or No. 6, press the [Paper Source] button to move to the corresponding pattern adjustment menu, then input the appropriate numerical values using the [Paper Feed + / -] buttons. After inputting the correction value, press the [Enter] button to print the results of the input correction values. The relationship between the inputs using the [Paper Feed + / -] buttons and the printing results is as shown below.
 - Adjustment value minimum resolution: 1/2880 Inch
 - Correction Direction: Paper Feed - Button = Moves the black lines in the 1st and 3rd passes toward the HP side.
Paper Feed + Button = Moves the black lines in the 1st and 3rd pass away from the HP side.
5. Repeat the above steps 3 and 4 until the adjustment of patterns No. 5 and No. 6 is completed.
6. After confirming that "GAP End." is displayed in the LCD, execute the final check items.
- Adjustment Target: There should be no deviation in the black lines and the light cyan lines.

SENSOR ADJUSTMENT

This adjustment is performed for the following purpose.

- Since the configuration of the base machine differs from that of the machine following the upgrade, the level corresponding to tracing paper differs, so the printer's sensors are adjusted appropriately in accordance with the MAIN board's sensors' and firmware configuration.

NOTE: *In this printer's specifications, successful printing using tracing paper is not guaranteed. We stop at the point of improving the sensors' sensing level to the point where they are capable of sensing tracing paper.*

In the Stylus Pro 9000, which is the base machine in the upgrade service, the following machines, roughly divided into two types are common in the market.

Table 4-11. Differences in Stylus Pro 9000 Models

	Main Board (VR1, VR2, VR3)	P_FRONT/ REAR Sensor	Firmware
Type 1	30k ohm	Old	Old
Type 2	100k ohm	New	Version J03003 or later.

The above Type 1 and Type 2 machines correspond to the following serial numbers.

Table 4-12. Serial Number for Type 1 and 2 mechanism

Destination	Type 1	Type 2
EAI 120V	- BJ60002321	BJ60002322 later
EAI 220V	- BJ70000001	BJ70000002 later
EUL 240V	- BJ80001101	BJ80001101 later
EUL 230V	-----	BJ90000001later
EURO	- BJA0002007	BJA0002008 later
EAL	- BJB0000126	BJB0000126 later
ESP	- BJC0000191	BJC0000192 later
ECC	- BTL0000517	BTL0000518 later
EHK	- BJD0000144	BJD0000144 later
ETT	- BJE0000229	BJE0000229 later
EKL	- BRN0000164	BRN0000165 later

Affected models have the same class of paper sensing capacity as the Stylus Pro 9500.

In the above Type 1 models, the paper detection sensor adjustment range is low and it is difficult for them to detect special papers such as tracing paper. Type 2 models have undergone the following improvements and their paper detection capacity has been improved to where they can even detect special papers such as tracing paper.

- The adjustment range of VR1, VR2 and VR3, which determine the paper detection sensor adjustment range, is broad.
- In the software aspect also, the printer is equipped with sequences which make corrections in software when measuring the stray light volume and when detecting paper.
- The sensor shape have been changed to where it is more difficult for the sensors to be influenced by stray light.

CAUTION



- For the reasons given on the preceding page, depending on the base unit's serial code and the firmware version, the adjustment methods for the P_FRONT / REAR / EDGE sensors differ, so the appropriate adjustment should be made.
- If the same sensor adjustment as that for a Type 2 unit is performed for a Type 1 unit, the sensor's sensitivity will rise too high and it will be easy for it to be influenced by stray light, and it may no longer be impossible for it to correctly detect EPSON genuine paper.
- If you are turning the VR1, VR2 and VR3 volume resistors on the main board to make adjustments, care should be taken not to touch the other elements on the board or the frame, etc. It is recommended that a screwdriver that is not conductive be used for this adjustment.
- It is easy for each sensor to be influenced by stray light from the sun or from the room lighting, etc. The P-FRONT sensor in particular is easily influenced by stray light, so printing should always be done with the printer covers securely in place.
- If the specified paper is set in the printer for each sensor adjustment, the paper set lever should be moved to the paper set position securely so as to stabilize the paper over the sensors.

CAUTION



The papers used for this adjustment (PPC, Kimoto Tracing Paper #300) should be replaced periodically. If there is any dirt (ink, foreign matter adhering), damage (wrinkles, tearing) in the standard paper, an accurate adjustment cannot be made, so the standard paper should be replaced after adjustment of about 20 printer units.

CHECK POINT



- Since the new pigment based firmware is written to the flash ROM by this upgrade service implementation, the display in the sensor adjustment mode's LCD display is as shown below. The meaning of each value is also shown below.
 - Panel Display: "Sen: Sensor Name A D ttt vvv"
 - ttt = Difference between the sensing level when there is no paper and when there is paper. This numerical value is shown in Hexadecimal and changes depending on the printer's state.
 - vvv = Sensor detection level when there is paper. The hexadecimal number during the adjustment changes depending on the VR element's adjustment level and the printer's state.

□ VR Chip Positions and Functions

Each VR element can be adjusted by opening the access cover on the paper guide. Each VR element is located in the positions shown below on the main board.

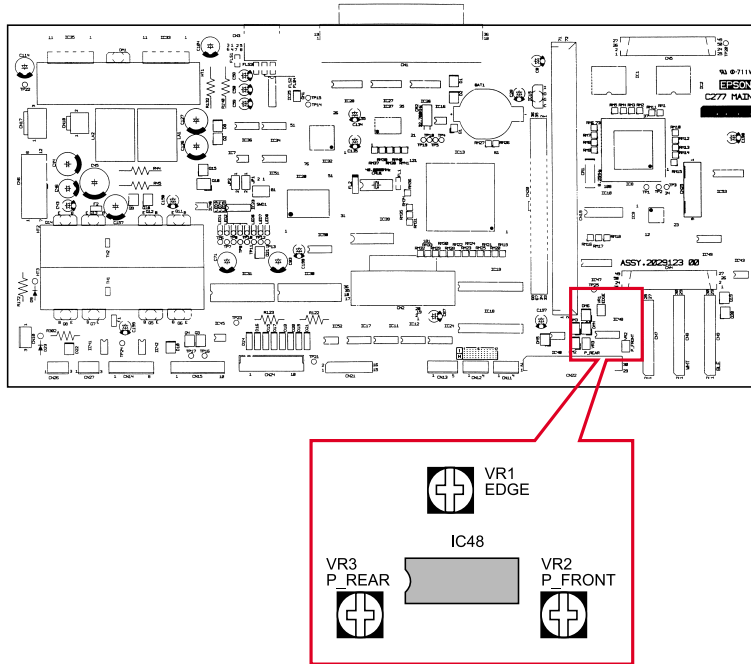

Figure 4-109. Locations of VR Elements on the Main Board

The function of each VR element is as shown in the table below.

Table 4-13. VR Element Function

Sensor	VR Element
P_EDGE Sensor	VR1
P_FRONT Sensor t	VR2
P_REAR Sensor	VR3

TYPE 1 PRINTER MECHANISM SENSOR ADJUSTMENT

□ P_EDGE Sensor

1. Remove the paper from the printer.
2. The self-diagnostic mode is started by turning on the Power switch while pressing the following buttons.
 - Paper Feed – Button + Cut / Eject Button + Cleaning Button

Press the [Paper Source] button and select “Check: Test”, then press the [Enter] button.

3. Press the [Paper Source] button and select “Test : Sensors”, then press the [Enter] button.
4. Press the [Paper Source] button and select “Sen: Edge AD.” At that time, make sure that the LCD displays “Sen: Edge AD ttt vvv.”

NOTE: NOTE: “ttt” or “vvv” is a hexadecimal number that changes depending on the printer’s state.

5. As necessary, the access cover on the paper guide should be removed. Open the front cover, release the CR lock, then move the CR unit about 20 cm from the right edge of the paper guide L.
6. Confirm that the LCD displays the following.
 - LCD Display: “Sensors: Edge AD ttt vvv”
 - ttt value: The numerical value is not related to anything.
 - vvv value: Should be a value 018<H> or lower.

If the vvv value is higher than 018<H>, adjust the VR1 element so that the vvv value is 018 <H> or lower. After the adjustment, return the CR unit to the HP position manually.

7. Raise the paper set lever, then set a sheet of A3 size plain copy paper (PPC paper) in the paper path, then lower the paper set lever to fix the paper in position. At this time, make sure the front edge of the sheet of paper is at the paper front edge setting position on paper guide L.
8. Move the CR unit over the paper and close the front cover halfway. At this time, if the vvv value in the LCD display does not change, the subsequent operation can be performed with the front cover in the open state. If the vvv value changes, use adhesive tape, etc. to fix the front cover in the half closed state.

NOTE: *NOTE: Move the CR unit over the paper so that the CR unit's right edge is aligned with the paper's right edge.*

9. Confirm that the LCD displays the following.
 - LCD Display: "Sen: Edge AD ttt vvv"
 - ttt value: 040<H> or higher
 - vvv value: 0A0<H> ~ 0E0<H>.

If the vvv value in the LCD display is not within the 0A0<H> ~ 0E0<H> range, adjust VR1 while checking the value of vvv displayed in the LCD.

10. Return the CR unit to the HP position.
11. Raise the paper set lever, then after removing the paper, return the paper set lever to the paper set position.
12. Press the [Paper Source] button and move the next adjustment mode.

□ P-FRONT Sensor Adjustment

1. Confirm that "Sen: FRONT AD ttt vvv" is displayed in the LCD and that the front cover is in the closed state.
2. Confirm that the following is displayed in the LCD.
 - LCD Display: "Sen: FRONT AD ttt vvv"
 - ttt value: The numerical value is not related to anything.
 - vvv value: Should be a value 025<H> or lower.

If the vvv value is higher than 025<H>, adjust the VR2 element so that the vvv value is 025<H> or lower.

3. Raise the paper set lever, then set a sheet of A3 size plain copy paper (PPC paper) in the paper path along the roll paper cover's guide, then lower the paper set lever to fix the paper in position. At this time, make sure the front edge of the sheet of paper is at the paper front edge setting position on paper guide L.
4. Close the front cover halfway. At this time, if the vvv value in the LCD display does not change, the subsequent operation can be performed with the front cover in the open state. If the vvv value changes, use adhesive tape, etc. to fix the front cover in the half closed state.

NOTE: *Move the CR unit over the paper so that the CR unit's right edge is aligned with the paper's right edge.*

5. Confirm that the LCD displays the following.
 - LCD Display: "Sen: FRONT AD ttt vvv"
 - ttt value: 040<H> or higher
 - vvv value: 0A0<H> ~ 0E0<H>.

If the vvv value in the LCD display is not within the 0A0<H> ~ 0E0<H> range, adjust VR2 while checking the value of vvv displayed in the LCD.

6. Raise the paper set lever, then after removing the paper, return the paper set lever to the paper set position.
7. Press the [Paper Source] button and move the next adjustment mode.

□ P-REAR Sensor Adjustment

1. Confirm that “Sen: REAR AD ttt vvv” is displayed in the LCD and that the front cover is in the closed state.
2. Confirm that the following is displayed in the LCD.
 - LCD Display: “Sen: REAR AD ttt vvv”
 - ttt value: The numerical value is not related to anything.
 - vvv value: Should be a value 025<H> or lower.

If the vvv value is higher than 025<H>, adjust the VR3 element so that the vvv value is 025<H> or lower.
3. Raise the paper set lever, then set a sheet of A3 size plain copy paper (PPC paper) in the paper path along the roll paper cover’s guide, then lower the paper set lever to fix the paper in position. At this time, make sure the front edge of the sheet of paper is at the paper front edge setting position on paper guide L.
4. Close the front cover halfway. At this time, if the vvv value in the LCD display does not change, the subsequent operation can be performed with the front cover in the open state. If the vvv value changes, use adhesive tape, etc. to fix the front cover in the half closed state.

NOTE: Move the CR unit over the paper so that the CR unit’s right edge is aligned with the paper’s right edge.

5. Confirm that the LCD displays the following.
 - • LCD Display: “Sen: REAR AD ttt vvv”
 - • ttt value: 040<H> or higher
 - • vvv value: 0A0<H> ~ 0E0<H>.

If the vvv value in the LCD display is not within the 0A0<H> ~ 0E0<H> range, adjust VR3 while checking the value of vvv displayed in the LCD.
6. Raise the paper set lever, then after removing the paper, return the paper set lever to the paper set position.
7. Turn off the printer’s Power switch and close the access cover, tightening the installation screws.

TYPE 2 PRINTER MECHANISM SENSOR ADJUSTMENT

In case the Conversion base mechanism is Type2, sensor adjustment is not required because the Main board, Sensor, Firmware level is same as Stylus PRO 9500.

FINAL CHECK

- Check the auto cutter's paper cutting position.
Set the paper at about 10 cm below the level difference where paper is cut by the paper cutter, then release the CR unit lock manually and move it to the center of the paper.
Pierce the paper with the paper cutter manually, then cut the paper on the left and right. Confirm that the length from the cut edge of the paper to the level difference edge for the cutter on the sub-platen is within 0.5 mm \pm 0.2. For details, see page 207. If it is outside the standard, the necessary adjustments should be made.
- Printing Check in the Self-diagnostic Mode
 1. Start the Self-diagnostic mode by turning on the Power switch while pressing the following buttons.
 - Paper Feed – button + Cut / Eject button + Cleaning button
Press the Paper Source button to select "Inspection: Printing", then press the Enter key.
 2. Set the roll paper included in the conversion kit in the printer. After setting the paper, make sure the paper set lever is in the paper set position.
 3. Press the Paper Source switch to select "Printing" Nozzle Check," then press the Enter key, and the following items will be printed out.
 - Nozzle Check Pattern
Check if all the nozzles spray ink without any bending or missing of dots.
 - Firmware Version
Check if the firmware version is L0XX0X. (Note: The "X" will differ depending on the firmware version.)
 - Waste Ink Counter
Compare the counter value from the time this operation was being prepared for, with the counter value when the nozzle check pattern was printed out. Confirm that the value has gotten smaller.

NOTE: If initial filling has been exceptionally performed several times during this operation, the counter value that is printed out may actually be higher than the value printed out during the preparations.

- Vertical Nozzle Alignment Check Pattern
In this pattern, it should be confirmed that no irregular color (dark portions, light portions) are occurring in the patterns of each color. If extreme color irregularities are occurring, carry out KK2 Cleaning in the Self-diagnostic mode, and check if it recovers. If it doesn't recover, replace the heads.
- Horizontal Nozzle Alignment Adjustment Pattern
Confirm that there is no missing of dots and that there is no ink scattering in the horizontal direction, deviation, etc.
- Left Head Slant Adjustment Pattern
The Magenta and Black patterns should be arranged on the same line horizontally.
- Right Head Slant Adjustment Pattern
The Light Magenta and Light Cyan patterns should be arranged on the same line horizontally.
- Head Height Adjustment Pattern
The Light Magenta and Cyan patterns should be arranged on the same line horizontally.
- Bi-D Adjustment Pattern (Adjustment Results, #1 ~ #4)
Patterns #1 ~ #3 should line up along the same vertical line. For #4, the 8 patterns in each color should be checked for a block pattern with no overlapping and gaps. Recheck with another check pattern.
- Head Gap Adjustment Pattern (Adjustment Results #5, #6)
Patterns #5 and #6 should line up on the same vertical line.
- Bi-D Pattern #4 Check

Start Pout3.exe from the DOS prompt, then transfer the Bid333.Prn file to the printer and print out Bi-D pattern #4. Confirm that there are no gaps or overlapping in the center pattern of the 9 patterns in each color. For details, see page 144.

CHAPTER

5

ADJUSTMENT

5.1 Summary

This section describes the adjustment procedures necessary after replacing certain parts and explains how to perform those adjustment procedures.

5.1.1 Caution

Before beginning any adjustment procedure, make sure of the following.



- **Before starting any adjustment procedure, find the adjustment procedure you need to perform in Table 5-2 on page 158 and verify the order or the tasks you need to perform.**
- **When performing an adjustment procedure, double-check the detailed instructions and caution information for that procedure; otherwise you may damage the printer.**
- **When replacing the following, always install a new ink cartridge.**
 - Printheads
 - Main Board
 - "Holder, Assembly, Valve"

5.1.2 Adjustment Tools

The necessary tools for performing adjustment procedures on this printer are shown below. .

Table 5-1. Adjustment Tools

Name	Part Code	Notes
Tension Gauge	B747700300/ standard tool acceptable	Max. 4000g
Tension Gauge #F712	1047744/ standard tool acceptable	Max. 200g
Straight edge/ruler 1000mm #F713	1047746/ standard tool acceptable	Length: 1000mm
Scale Stopper #714	1047745/ standard tool acceptable	Used in combination with #F713 (0.1mm scale)
Paper Guide L Installation Position Adjustment tool #F755	Exclusive Part ASP Code: 1059434	Material: Plastic Color White
Cutter Installation Position Adjustment tool #F759	Exclusive Part ASP Code: 1059443	Material: Plastic Color: White
CR Cover-Position Adjustment Tool #F724	Special Tool 1049975	Material: Plastic Color: White
CR ENC Installation Adjustment tool #F766	Exclusive Part ASP Code: 1060655	Material: Plastic Color: White
PF ENC Installation Adjustment tool #764	Exclusive Part ASP Code: 1060658	Material: Plastic Color White
PF ENC Installation Adjustment tool 2 #765	Exclusive Part ASP Code: 1060657	Material: Plastic Color: White
Front Cover Positioning tool #F754	Exclusive Part ASP Code: 1059420	Material: Plastic Color White

Table 5-1. Adjustment Tools

Name	Part Code	Notes
Flash Memory Card #F727	1050073 standard PC card acceptable	Type: 2MB Flash memory card Standard: Type-II (PCMCIA Rel 2.1/ JEIDA Ver. 4.2) Voltage: 5V Read/Write
Kimoto Micro Trace Paper #F751	ASP Code: 1057723	Used for sensor adjustments.

5.1.3 Adjustment Items

All parts that require adjustment when being replaced are listed in the table below. You will also find a list of required adjustment procedures along with the order of those procedures.

Table 5-2. Service Parts & Required Adjustments

Service Operation	Step Number	Adjustment Items	Refer to
Printhead replacement	1	<Start the Self-Diagnostic Function>	
	2	<input type="checkbox"/> Capping position adjustment	page 170
		<input type="checkbox"/> Head rank input (and initial ink charge)	page 171
	3	<input type="checkbox"/> Head nozzle check	page 172
	4	<input type="checkbox"/> Head slant adjustment (B/C heads)	page 173
	5	<input type="checkbox"/> Head Height (Linear) adjustment	page 175
	6	<input type="checkbox"/> Bi-D adjustment	page 177
	7	<input type="checkbox"/> Head Gap adjustment	page 180
	8	<input type="checkbox"/> Test print	page 198
	9	<Head Unit Life Counter Reset>	page 201
	10	<Cutter Installation Position Adjustment>	page 205
	11	<CR Cover Height Adjustment>	page 208
12	<Paper Cutting Position Check>	page 207	
Main Board replacement <Caution> If it is possible to implement the adjustment sequence in the table at right, it is not necessary to perform any adjustments after item 4.	1	<Parameter Backup / Download>	page 162
	2	<DIP-SW Setting>	page 218
	3	<Firmware Reload>	page 164
	4	<Self-Diagnostic Function>	
	5	<input type="checkbox"/> Sensor Adjustment	page 192
	6	<input type="checkbox"/> Capping position adjustment	page 170
	7	<input type="checkbox"/> Head rank input (initial ink charge not necessary)	page 171
	8	<input type="checkbox"/> Bi-D adjustment	page 177
	9	<input type="checkbox"/> Head Gap adjustment	page 180
	10	<input type="checkbox"/> Flush point adjustment (L/R)	page 182
	11	<input type="checkbox"/> Feed adjustment	page 183
	12	<input type="checkbox"/> Top/bottom adjustment	page 184
	13	<input type="checkbox"/> Rear Sensor position adjustment	page 198
	14	<input type="checkbox"/> Test print	page 201
	15	<Replace the Waste Ink Pads and clear the counter>	

Table 5-2. Service Parts & Required Adjustments (continued)

Service Operation	Step Number	Adjustment Items	Refer to
CR Motor replacement	1	<CR Steel belt tension adjustment> •Required tool: Tension Gauge <Self-Diagnostic Function>	page 213
	2	<input type="checkbox"/> Capping position adjustment	page 170
	3	<input type="checkbox"/> Bi-D adjustment	page 177
	4	<input type="checkbox"/> Head Gap adjustment	page 180
	5	<input type="checkbox"/> Flush point adjustment (L/R)	page 181
	6	<input type="checkbox"/> Top/bottom adjustment	page 183
	7	<input type="checkbox"/> Test print	page 198
PF Motor replacement	1	<CR Steel belt tension adjustment> •Required tool: Tension Gauge <Self-Diagnostic Function>	page 213
	2	<input type="checkbox"/> Feed adjustment	page 182
	3	<input type="checkbox"/> Top/bottom adjustment	page 183
	4	<input type="checkbox"/> Rear Sensor position adjustment	page 184
	5	<input type="checkbox"/> Test print	page 198
<Sensor replacement> <input type="checkbox"/> P Front <input type="checkbox"/> P Edge	1	<Self-Diagnostic Function>	
	2	<input type="checkbox"/> Sensor Adjustment <input type="checkbox"/> Top/bottom adjustment	page 192 page 183
<Sensor replacement> <input type="checkbox"/> P Rear	1	<Self-Diagnostic Function>	page 192
	2	<input type="checkbox"/> Sensor Adjustment <input type="checkbox"/> Top/bottom adjustment	page 183
<Sensor replacement> <input type="checkbox"/> P Thick	1	<Self-Diagnostic Function> <input type="checkbox"/> From the "Test" menu select "Sensor" and then "Paper Thickness" •Required tool: Schema Gauge	page 215
<Sensor replacement> <input type="checkbox"/> CR Sensor	1	<CR Encoder Sensor Installation Position Adjustment>	page 210
<Sensor replacement> <input type="checkbox"/> Cover R/L Sensor	1	<Self-Diagnostic Function> <input type="checkbox"/> From the "Test" menu select "Sensor" and then "Cover"	page 215

Table 5-2. Service Parts & Required Adjustments (continued)

Service Operation	Step Number	Adjustment Items	Refer to
<Sensor Replacement> <input type="checkbox"/> Removal and replacement of the PF encoder sensor.	1	<PF ENC Installation Position Adjustment>	page 211
	2	<PF ENC Installation Position Adjustment 2>	page 211
<Sensor Replacement> <input type="checkbox"/> Cover R/L Sensor Assembly	1	<Front Cover Positioning Adjustment>	page 215
	2	<Start Self-diagnostic Function> <input type="checkbox"/> Execute "Covers" inspection under the item "Sensors" in the "Inspection" menu.	
Replace, removal and installation of the SLID motor gear assembly.	1	<Gear Backlash Adjustment>	page 214
• When Paper Guide L is removed and installed. • When the waste ink pads are replaced. • Pump assembly replacement • Cap assembly replacement, etc.	1	<Paper Guide Installation Position Adjustment>	page 204
	2	<Paper Cutting Position Check>	page 207
During disassembly of the I/H assembly.	1	<Latch Engagement Position Adjustment>	page 214

Table 5-2. Service Parts & Required Adjustments (continued)

Service Operation	Step Number	Adjustment Items	Refer to
<ul style="list-style-type: none"> • Removal and replacement of the PF encoder sensor. • Removal and replacement of the X reduction belt. 	1	<PF ENC Installation Position Adjustment>	page 211
	2	<PF ENC Installation Position Adjustment 2>	page 211
<ul style="list-style-type: none"> • When removing and installing the CR cover. • Replacing the print heads. • Replacing the cutter solenoid assembly, etc. 	1	<Cutter Installation Position Adjustment>	page 205
	2	<CR Cover Height Adjustment>	page 208
	3	<Paper Cutting Position Check>	page 207

5.2 Adjustment Steps

This section describes the detailed steps for performing the adjustment procedures listed in Table 5-2.

5.2.1 Parameter Backup

The Main Board contains Flash ROM memory which is used to store the parameter information and firmware commands that control the printer. For all corresponding printer parts, the individual and unique adjustment information and part codes are stored here, which allows the Main Board and Printer Mechanism to work together smoothly. This information must be kept up to date for the printer to work properly.

Therefore, before performing service that requires the removal of the Main Board, you need to back up all of the parameters in case you have to update a new Main Board which must work with the Printer Mechanism exactly the same way the old one did. Backing up the parameters also helps minimize the amount of and number of adjustments you may need to perform.



If you have backed up the parameters correctly, by rewriting these parameters to the new main board, the adjustments using the self-diagnostic function become unnecessary.

In this case, perform the operation by the following procedure.

1. **Back up the parameters. (See this item.)**
2. **Replace the main board. (See Chapter 4.)**
3. **Write the firmware. (See page 164.)**
4. **Download the parameters. (See this item.)**
5. **Adjust the sensors. (See page 192.)**

REQUIREMENTS FOR BACKUP

- #F727 PC Card (2 MB Flash Memory Card)

Part Code: 1050073

Commercially available PC cards can also be used. A PCMCIA Rel. 2.1 / JEIDA Ver. 4.2 (Type II) compatible PC card should be used. (Recommended: Fujitsu / Model No. MB98A81183-15)

- A PC which uses PC cards or a PC card writer.
- PC Card Writing Tool (Example: ADTEC CardUT97)



- **The voltage specification during writing to a PC card should be 5 V. (With a card other than this, the backup contents will be unsure and if they are downloaded to the circuit board, the data will become indefinite.)**
- **The PC card used here can be of the same type as the PC card used for reloading the firmware, but it is not possible to use the same card. (The data on the card are cleared.)**
- **The parameter buffer IPL can be used in common with that of the Stylus Pro 9000.**

- IPL Data

Separately supplied data should be written to a PC card in advance for use in backing up.

Data File Name: BACKUP.EXE

(Self-extracting format file / The generated files are written to the PC card after extracting.)

5.2.1.1 Operating Procedure

Backup to a PC card and transfer of parameter data from a PC card to NVRAM on the main board is accomplished by the following procedure.

BACKUP OF PARAMETERS TO A PC CARD

- Backing up (uploading) data to the PC card
- 1. Remove the access cover the top of the Upper Paper Guide, if necessary. Also, make sure the Control Panel unit is attached.
- 2. Insert the PC card into the PC card slot connector on the Main Board, and then turn on the printer.
- 3. Make sure the following message appears on the LCD, and wait for the procedure to begin.

Wait:F->M Push:M->F

- 4. The backup procedure starts about 15 seconds after the message appears.

Flash -> Mcard



Do not touch the Control Panel buttons during this procedure. Doing so causes the PC card to download its data to the Main Board's Flash memory instead of backing up the data in Flash memory. This overwrites the Flash memory so be careful.

- 5. When the backup procedure is finished, the following message appears.

End [Success]

- 6. After making sure the printer is finished, turn off the printer and remove the PC card.

- Downloading the data from the PC card to the printer
- 1. Make sure the access cover is removed from the top of the Upper Paper Guide, add make sure the Control Panel is attached.
- 2. Insert the PC card containing the backup data into the PC card slot connector on the Main Board, and turn on the printer.
- 3. Make sure the following message appears on the LCD.

Wait:F->M Push:M->F

- 4. Press any button on the Control Panel to start the download procedure.

Mcard -> Flash



If you wait 15 seconds before you press one of the Control Panel buttons, the printer will start the backup procedure instead of the download procedure. This overwrites data stored in the PC card with data stored in the Main Board Flash memory.

- 5. When the download procedure is finished, the following message appears.

End [Success]

- 6. After making sure the printer is finished, turn off the printer and remove the PC card.

OTHER/NOTES

If an error occurs during the backup or download procedure, the following message appears on the LCD.

End [Error]

If you see the message above, one of the following errors has occurred. Using a different PC card, try the operation again.

If using a different PC card does not solve the problem, there is a problem with the flash memory on the Main Board and a backup is not possible.

- Flash memory/ write error
- Flash memory/ erase error
- PC card/ write error
- PC card/ erase error

5.2.2 Firmware Update

Since the firmware is written into the Flash ROM on the Main Board, to replace the Main Board you need to write the firmware to the new Flash ROM on the new Main Board as described below.



- **When the printer's power is turned on immediately after reloading the firmware, the ink initial refilling operation starts. If initial refilling is not necessary, be sure to start the printer by the following procedure.**

1. **Start the Self-diagnostic function when the power is turned On.**
2. **Select "Parameters: Update" under "Diagnostic: Parameters."**
3. **Select "Update: Ink Parameters."**
4. **Select "Reset" in "Initial Ink Filling Flag."**
5. **Turn the printer's power switch Off, then turn it On again.**

- **The correct firmware data file should be used to match the download method.**

- **Via PC: V0XX0X.IPL**
- **PC Card: V0XX0X.ROM**

Note): "X" in the above differs depending on the version.

UPDATING VIA THE PC

1. Make sure the printer and PC are connected using a parallel or serial connection.
<Parallel Connection>

This function is valid only when the PC BIOS setting has Compatible Mode connections enabled. Make sure that it is not set in the ECP mode.

2. If the printer's power is turned On while pressing the following buttons, "Data Transfer" is displayed in the LCD and the LED for the Yellow ink lights up.

"Paper Source" + "Eject" + "Cleaning"

3. From the PC, send the firmware program to the printer as follows.
<Parallel Connection>
From the DOS prompt, type "**copy [filename] prn:**" and press Enter.
4. Reloading of the firmware will start, and the following messages will be displayed in order in the LCD panel.
"Flash Erase" _ "Flash Write" _ "Complete" _ "Program Load End"
5. Turn the printer off, and then back on.

RELOADING FROM A MEMORY CARD

1. Turn the printer's power off.
2. Remove the access cover on Paper Guide U on the back of the printer, then insert a memory card (Flash memory card) with the firmware data already recorded on it in the card slot on the main board (CN20).
3. Turn the printer's power On.
4. Reloading of the firmware will start and the following messages will be displayed in order in the LCD panel
"Flash Erase" _ "Flash Write" _ "Complete" _ "Program Load End"
5. Turn the printer's power Off, then after removing the memory card, turn the power on again.



- **Whichever method is used, if update processing is interrupted midway through the process, (by the power being turned off, etc.), it is possible to recover by starting the operation again.**
- **It is possible to use the following PC cards and card writers (their operation has been confirmed).**
<PC Card> 2 MB / Flash Memory Card
 - #F727 PC Card (Code: 1050073)
(Fujitsu Memory Card (MB98A81183-15) or comparable product)
Or a commercially available product (5 V, single power supply R/W specification product)<PC Card Writing Utility>
 - ADTEC System Science Card Utility 97

5.2.3 Self-Diagnostics

This section gives detailed descriptions of the items in Table 5-2, "Service Parts & Required Adjustments," on page 158.

5.2.3.1 Entering Self-Diagnostic Mode

1. Push down the Release Lever to the Lock position.
2. Press the following buttons on the Control Panel while turning on the printer.

Paper Feed ↓ + Cut/Eject + Cleaning

3. When "Check: Test" appears on the LCD, the printer has entered the Self-Diagnostic mode.

Use the Control Panel buttons to activate a Self-Diagnostic function, as described in the table below.

Table 5-3. Self-Diagnostic Mode Controls

Normal Function	Self-Diagnostic Function	Meaning
Pause	Return up one level	Moves up one level (without selecting at item).
SelecType	Next menu	Displays the next menu.
Paper Source	Previous menu	Displays the previous menu.
+ (Paper Feed ↑)	Next item or value	Displays the next item or increases the value of the item shown on the LCD.
- (Paper Feed ↓)	Previous item or value	Displays the previous item or decreases the value of the item shown on the LCD.
Cut/Eject	Enter	Selects/activates the item.

To exit the Self-Diagnostic mode, turn off the printer.

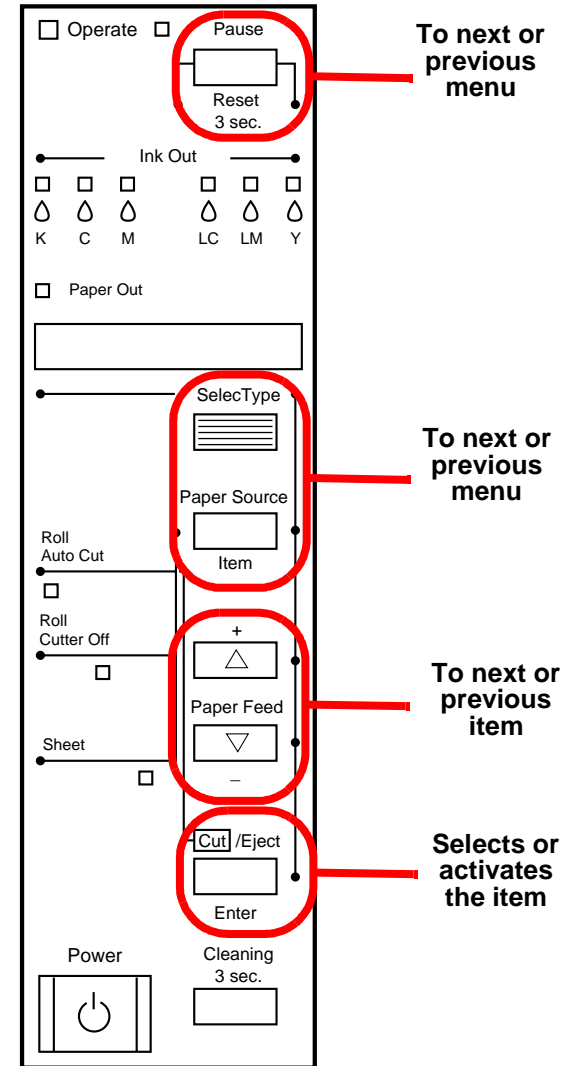

Figure 5-1. Self-Diagnostic Controls

5.2.3.2 Self-Diagnostic Mode Menus

In the Self-Diagnostic mode, you can select from the following menus.

Table 5-4. Self-Diagnostic Menu

Message	Description
Check: Test	Verifies certain information such as RAM, version number, panel, sensors, fatal-error history and encoder.
Check: Adjustment	Adjusts certain mechanism such as printheads, sensors, and feed path.
Check: Cleaning	Starts initial ink charge or predetermined cleaning sequence
Check: Print	Prints nozzle check pattern or adjustment parameter list
Check: Parameter	Updates or clears all of the adjustment parameters
Check: Life	Tests the operation of the printer components.



- The "Check: Life" menu contains tests that should only be performed at the factory, so do not attempt to use this menu.
- In Self-Diagnostic mode, all of the tests except for one (Rear Sensor adjustment) assume that you have loaded roll paper. Even if you load single sheets, the printer handles the paper as if it were roll paper.
- All explanations in this mode refer to the printheads in the following way:
 B head = K/C/M side (left side facing the printer)
 C head = Lc/Lm/Y side (right side facing the printer)

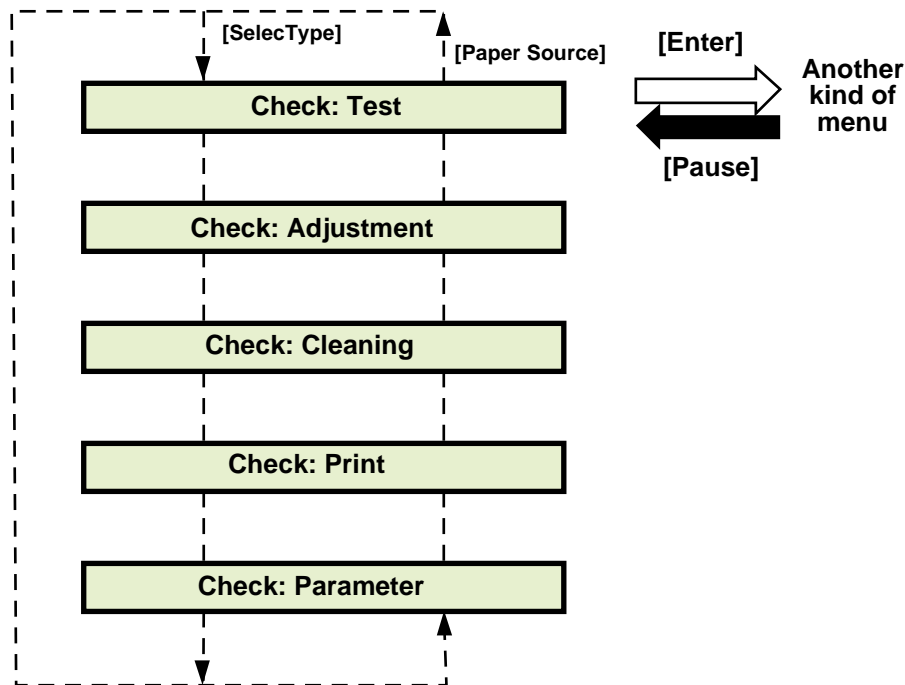

Figure 5-2. Self-Diagnostic Menu Flow

5.2.4 Adjustment Menu

The Adjust menu allows you to make certain adjustments to the printer mechanism and controls, for example head angle adjustment, print position adjustment, paper feeding correction, and firmware-control setting.

Table 5-5. Adjustment Menu Items

Adjustment Item	Description
Capping Position	Sets the Capping position (automatic Adjustment)
Paper Skew Check	Verifies the degree of skew (slant) allowed during printing
Head Rank Input	Sets the printhead ID
Head Nozzle Check	Prints the check pattern to make sure the nozzles are not clogged
B Head Angle	Adjusts the angle of the B Head (mechanism adj.)
C Head Angle	Adjusts the angle of the C Head (mechanism adj.)
BC Head Height	Verifies the B/C Head nozzles are at the same height (mechanism adj.)
Bi-D Print Position	Verifies the printed lines match up when performing bi-directional printing.
Head Gap	Adjusts the B/C Head Gap as well as sets the left margin
R Flush Point	Adjusts the flush position on the HP side
L Flush Point	Adjusts the flush position on the opposite side
Feed Correction	Checks paper feeding (w/ruler)
Top & Bottom	Checks the top and bottom margins (w/ruler)
Rear Paper Sensor Position	Sets the detection position of the rear paper-edge sensor
Test Pattern Print	Checks print quality (prints setting information, check pattern and so on)
Head Cleaning	Initiates cleaning/flushing of the heads and ink path
Counter Clear	Resets all counters



- **When conducting on-site service/repairs, do not select "Head Cleaning" as this requires a separate head cleaning cartridge to work properly.**
- **Only select "Counter Clear" when replacing the Waste Ink Pads and related parts.**

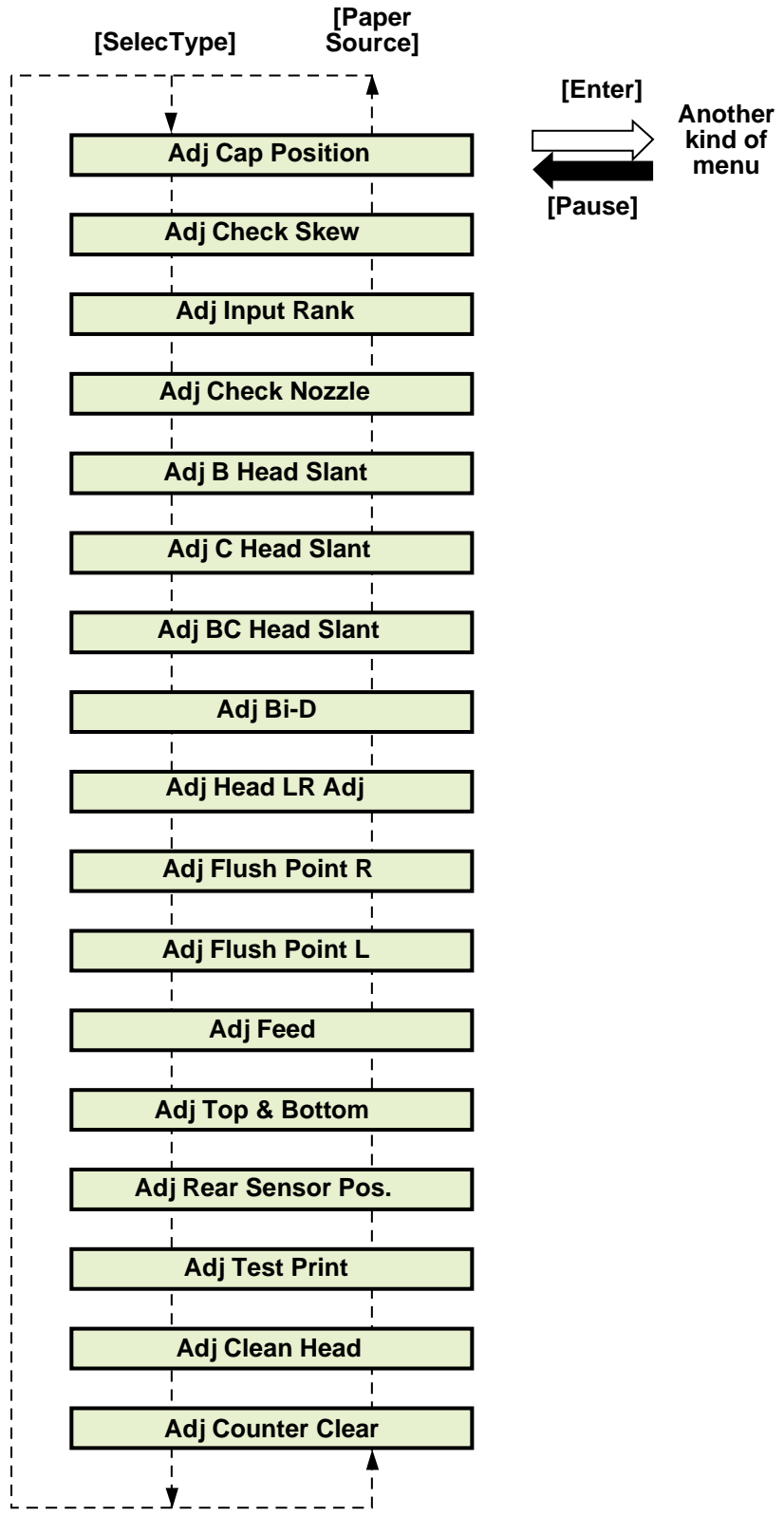

Figure 5-3. Adjustment Menu

ADJ CAP POSITION

Use this function to check the actual capping position and correct the capping position parameter in the firmware if necessary.

There may be very small differences between printers. Although the difference may only be a few pulses closer or further the linear encoder, This is necessary to correct for any differences between one mechanism and another.

1. Make sure "Adj Cap Position" appears on the LCD and press the Enter button.
2. The printer begins the HP detection sequence and automatically detects the capping position.
3. After the adjustment process is finished, the detected distance between the HP and the capping position is displayed.
4. Pressing the Enter button updates the capping position parameter and displays the next menu item. Pressing the Pause button does not update the capping position parameter and returns you to the beginning of this function; Adj Cap Position appears on the LCD

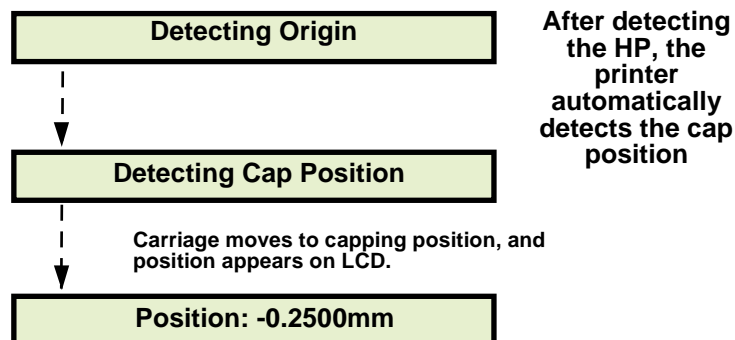

ADJ CHECK SKEW

When the band turns a predetermined amount (during printing), the printer detects the paper edge using the P EDGE sensor. This value is compared to the originally detected value for the paper-edge position to determine if the paper is feeding at a slant. This adjustment is for service printouts and does not affect user printouts.

1. Make sure "Adj: Check Skew" appears on the LCD and press the Enter button.
2. If the paper is not loaded correctly, "Reload Paper" appears indicating you need to properly load the paper. If the paper is set correctly, the printer initializes the paper.
3. After paper is loaded and initialized, "Check Skew 1.0m" appears. Use the Paper Feed + and Paper Feed - buttons to adjust the distance between paper-skew detection checks in increments of 0.1m.
4. After setting the distance between checks, press the Enter button to begin the detection operation. After the skew is correctly detected, "Skew Result: xxxx" appears. A "+" before the number indicates the paper is skewed to the HP side, and a "-" indicates the paper is skewed away from the HP.
5. Pressing the [Enter] button updates the skew correction parameters and moves to the next adjustment item. Pressing the Pause button does not update the capping position parameter and returns you to the beginning of this function on; Adj Check Skew appears on the LCD.

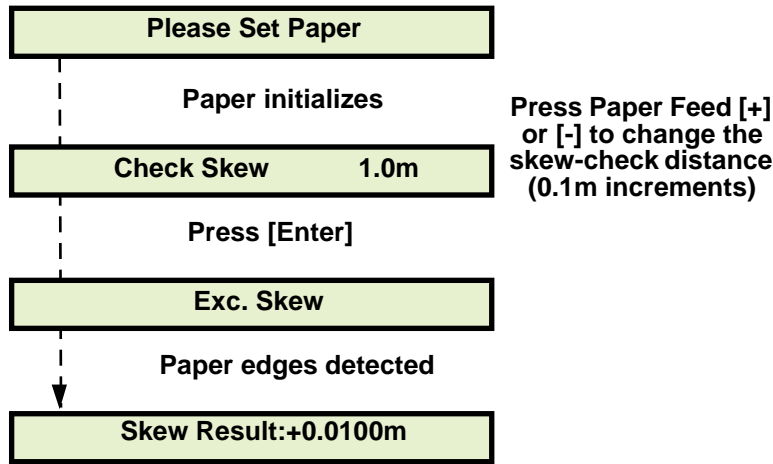

- After entering the head ID for both printheads, press the Enter button and "Enter Key" appears on the LCD. Press the Enter button again to write the printhead ID value to the Main Board and begin the initial-ink charge in the heads.

➔ After entering B & C head ID's, "Enter Key" appears on the LCD. To avoid wasting ink, if you do not replace the printheads, press the Pause button instead of the Enter button to skip the initial-ink charge process.

ADJ INPUT RANK

NOTE: Not necessary if you replace the Main Board but do not replace the printheads.

This function allows you to enter the B head and C head ID's.

- Make sure "Adj: Input Rank" appears on the LCD and press the Enter button.
- Make a memo of the 6-digit ID printed on the head ID label affixed to the head.
- First enter the B head (K/C/M) ID. Press the Paper Feed + or Paper Feed - button to select the ID value. After correctly entering the B head ID, press the Enter button to begin entering the C head ID. If an out-of-range error ("Error Rank Input") occurs, press the Enter button and re-enter the ID.

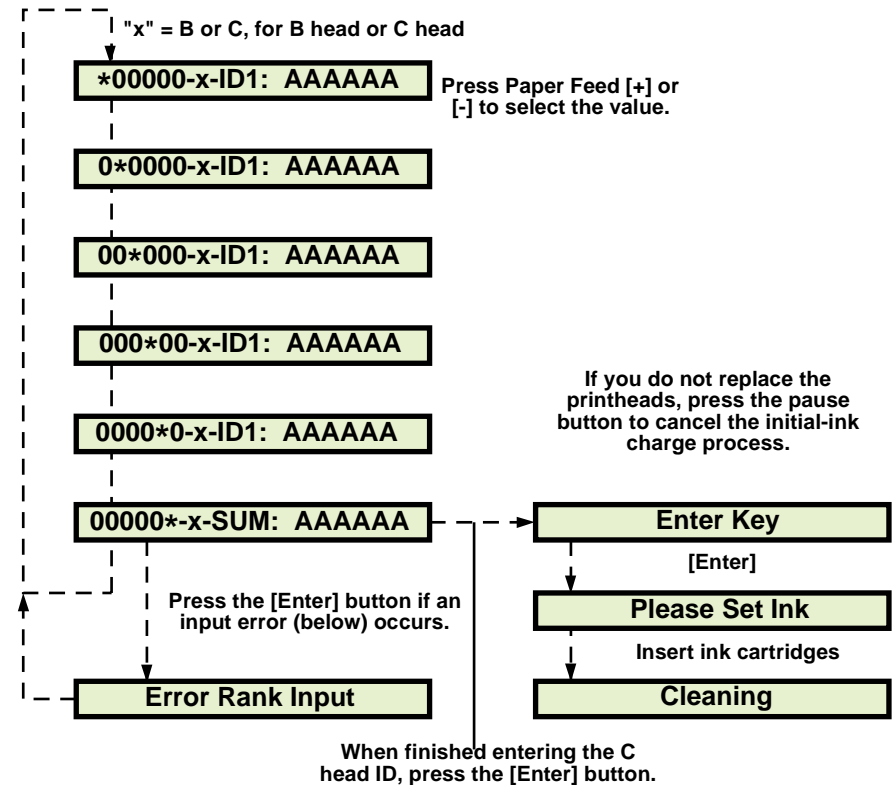

ADJ CHECK NOZZLE

After the initial ink charge, this function verifies that the nozzles are properly firing ink. If some nozzles are not firing correctly or at all, you can run the cleaning operation from this menu.

1. Make sure "Adj: Check Nozzle" appears on the LCD and press the Enter button.
2. Load paper if not already loaded and replace any low or empty ink cartridges if detected. If these conditions are OK, the printer prints the following check pattern.

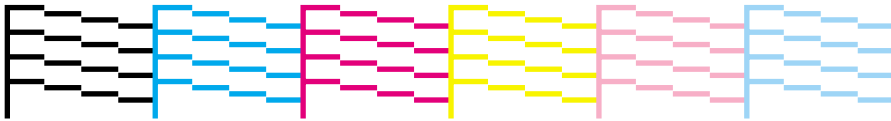

The pattern includes the following colors from left to right; black, cyan, magenta, yellow, light magenta, and light cyan.

- Also, after the above patterns, the following items are printed at the same time.
 - Firmware version
 - Waste ink counter remaining capacity (%)
 - Vertical nozzle alignment check pattern
 - Horizontal nozzle alignment check pattern

3. When the check pattern is finished printing, "Nozzle Check End" appears on the LCD. If the pattern printed all six colors properly with no lines or dots missing, press the Enter button to end this adjustment procedure. If lines or dots are missing, press the SelectType button to start the cleaning cycle.

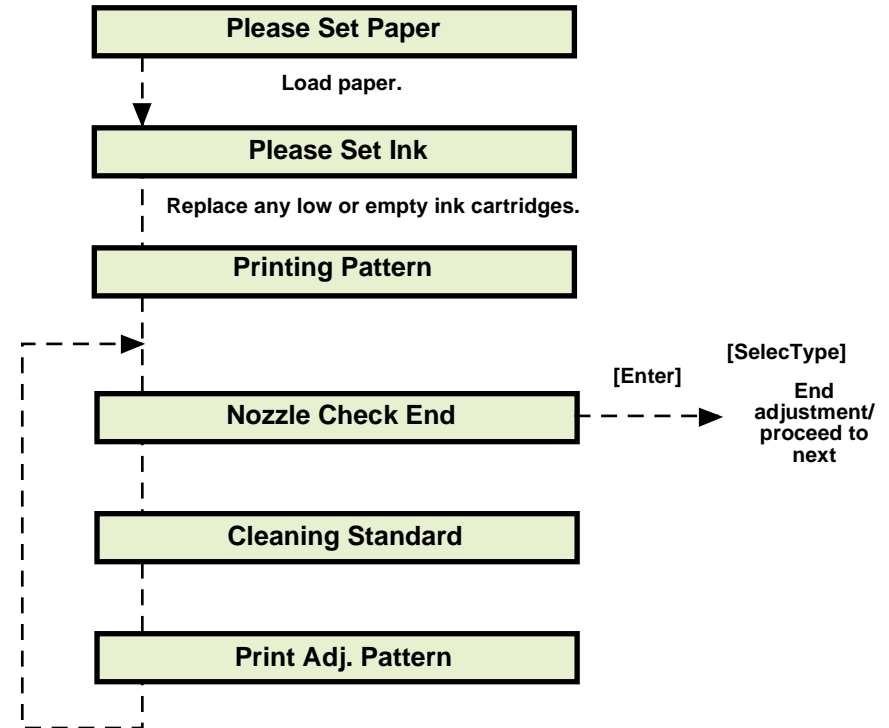

ADJ X HEAD SLANT (B/C HEADS)

This function prints a check pattern (one-at-a-time for each head) to make sure the printheads are installed straight up-and-down. If the pattern confirms one or both heads are offset, at a slant, use the corresponding "Head Adjust Lever A" to straighten the slanted head.

1. Make sure "Adj: x Head Slant" appears in the LCD, and press the Enter button. (x = B or C depending on the printhead)
2. After the check pattern prints, "x Slant Check End" (x = B or C head) appears in the LCD. Compare the printed pattern with the illustration below. Press Enter if the adjust level is OK like the top row shown below. If there is a slant, open the front cover, release the carriage lock by hand, and move the carriage away from the carriage cap position. Next remove the CR cover and loosen the installation screws in the affected head, then correct the "Head Adjuster A" to correct the inclination. Then tighten the head installation screws. The movement direction of the head adjuster at this time is as follows depending on the degree of inclination. (The check pattern color will differ during C head adjustment.)

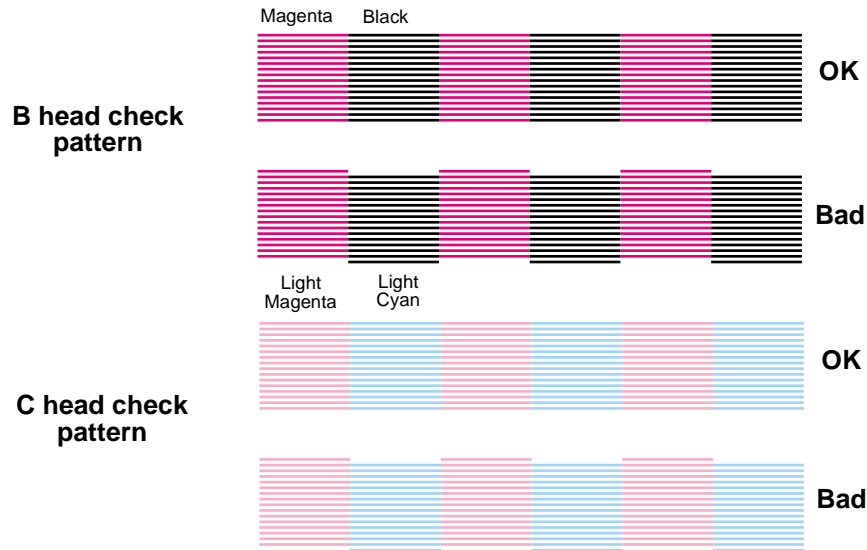

3. After finishing the slant-adjustment procedure for both heads, move the carriage back to the capping position by hand and close the front cover.

4. Make sure "x Slant Check End" appears, and press the Enter button if the check pattern prints with no slant. Press the SelecType or Item button if the pattern contains slants and you have adjusted the heads. (You may need to repeat.)

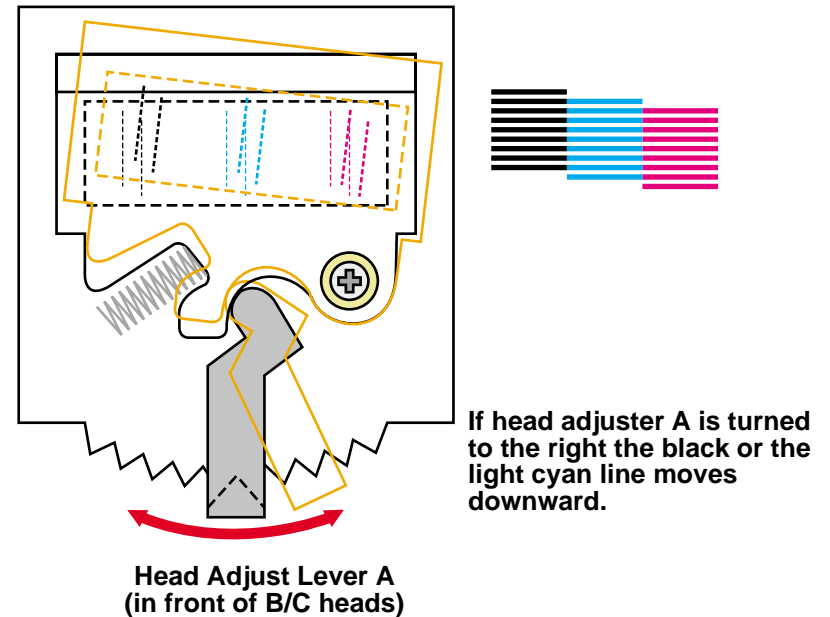
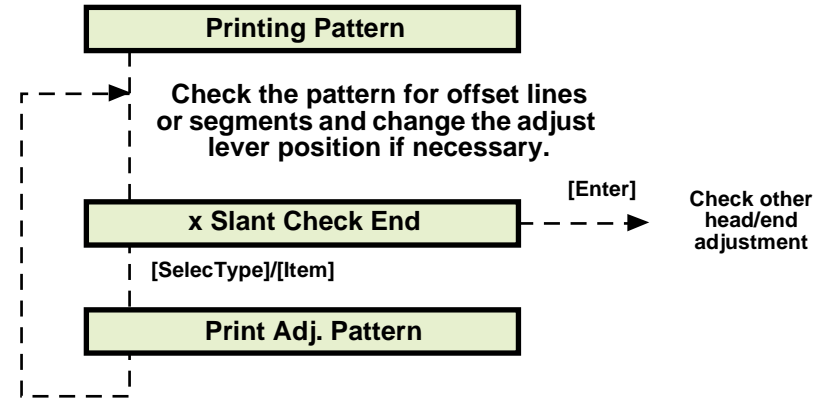

Figure 5-4. B/C Head Skew Adjust Lever



The CR cover is removed in this adjustment, so the following adjustment and check should be carried out.

- CR Cover Height Adjustment. Refer to page 208.
- Paper Cutting Position Check. Refer to page 207.

ADJ B/C HEAD HEIGHT (COLOR HEAD HEIGHT ADJUSTMENT)

This function matches the height of the B head nozzles and C head nozzles. Assuming the B head nozzles are correct, The printer prints a test pattern and if the two sets of lines do not match up vertically, you need to adjust the height of the C head using the Head Adjust Lever B.

1. Make sure "BC Slant Check End" appears in the LCD, and press Enter.
2. After the check pattern prints, "BC Slant Check End" appears in the LCD. Compare the printed pattern with the illustration below. Press Enter if the adjust level is OK like the top row. If there is a slant, open the front cover, release the carriage lock by hand, and move the carriage away from the carriage cap position. Next remove the CR cover and loosen the installation screws in the affected head, then correct the "Head Adjuster B" to correct the inclination. Then tighten the head installation screws. The movement direction of the head adjuster at this time is as follows depending on the degree of inclination.



3. After finishing the slant-adjustment procedure for both heads, move the carriage back to the capping position by hand and close the front cover.

4. Make sure "BC Slant Check End" appears, and press the Enter button if the check pattern prints with no misalignment. Press the SelecType or Item button if the printed pattern contains misalignment and you have adjusted the heads. (You may need to repeat.)

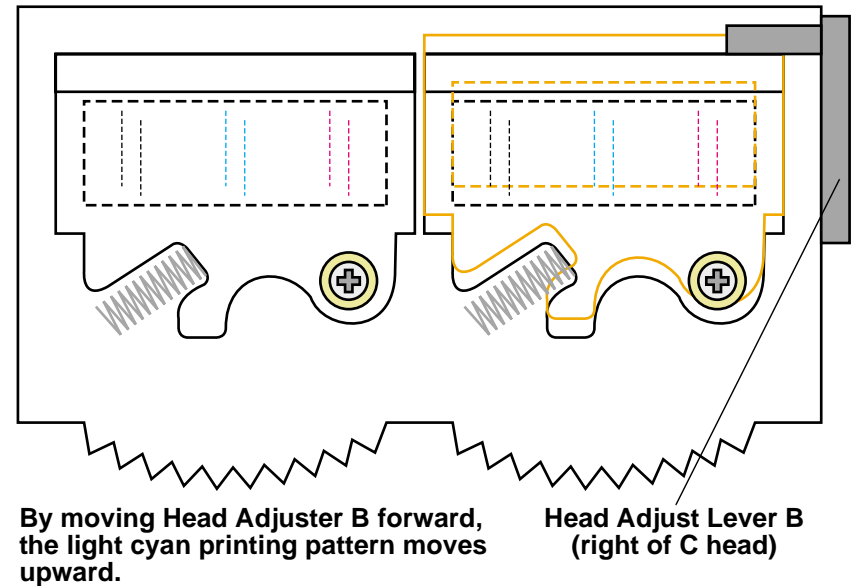
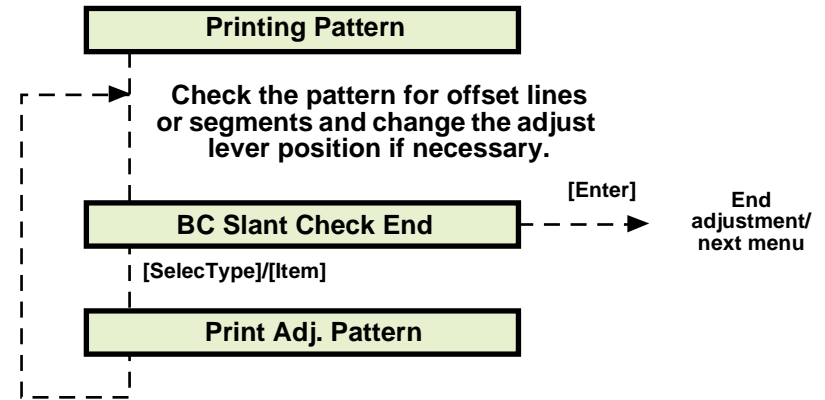

Figure 5-5. B/C Height Adjust Lever



The CR cover is removed in this adjustment, so the following adjustment and check should be carried out.

- CR Cover Height Adjustment
- Paper Cutting Position Check

ADJ BI-D

This function adjusts the Bi-D print position for both printheads. The printer prints a test pattern in both directions (toward the HP and away from the HP), and lines that do not line up vertically indicate the heads need Bi-D adjustment. The Bi-D adjust items are shown in the table below.

Table 5-6. Bi-D Adjust Items

Item	Description	Number
BiD/200/M/B	Bi-D adjustment/240cps/Normal-dot/B head	1
BiD/200/M/C	Bi-D adjustment/240cps/Normal-dot/C head	2
BiD/300/M/B	Bi-D adjustment/333cps/Normal-dot/B head	3
BiD/300/M/C	Bi-D adjustment/333cps/Normal-dot/C head	4

NOTE: The numbers in the above table show the number of the printing adjustment pattern printed out initially when printing the adjustment patterns. By pressing the Paper Source button, select “Check: Adjustments,” then press the Enter button.

1. Display “Adj: Bi-d” , then press the Enter button.
2. The message “Pattern printing” will be displayed in the LCD and the Bi-D adjustment patterns will be printed out.
3. When all four Bi-D adjustment patterns have been printed, the message “BI-D, 200. M. B: XXX” will be displayed in the LCD.
4. Check printing patterns No. 1 to No. 3, confirming if the vertical lines in the first pass deviate from the vertical lines printed in the second pass.
 - If there is no pattern deviation in printing patterns No. 1 to No. 3, press the Paper Source button 3 times and proceed to the printing pattern No. 4 adjustment menu. (Proceed to Step 9.) Confirm that “Bi-D, 300. N. C” is displayed in the LCD.
 - If there is pattern deviation in printing patterns No. 1 to No. 3, press the Paper Source button several times to proceed to the adjustment menu for the affected pattern, then press the Paper Feed + or – button to input the appropriate numerical value. After inputting the correction value, press the

Enter button. The printer will then print out the pattern with the results of the input correction value. The relationship between the inputs using the Paper Feed + or – button and the printing results is as shown below.

- Adjustment Value Minimum Resolution: 1/2880 inch
- Correction Direction: Paper Feed – button = Moves the line on the 2nd pass toward the HP side.
Paper Feed + button = Moves the line on the 2nd pass away from the HP .
- Adjustment Target: There should be no deviation between the lines on the first pass and the lines on the 2nd pass.

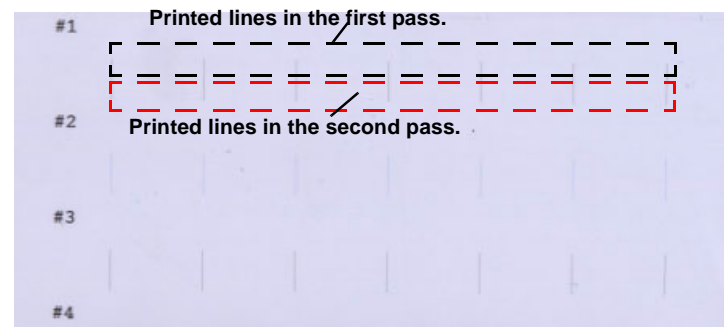

Figure 5-6. Bi-D Adjustment Patterns No. 1 ~ No. 3.

5. Repeat the above steps 2 and 3 in order to carry out the adjustment of Bi-D printing patterns No. 1 to No. 3.
6. Select “ND Base Value Adjust xx” by pressing the Paper Source Button. Check the results of printing Bi-D adjustment pattern No. 4 and check whether the following patterns exist in the 8 patterns each of light cyan, light magenta and yellow. The pattern No. of each pattern is printed in hexadecimal notation beneath it.

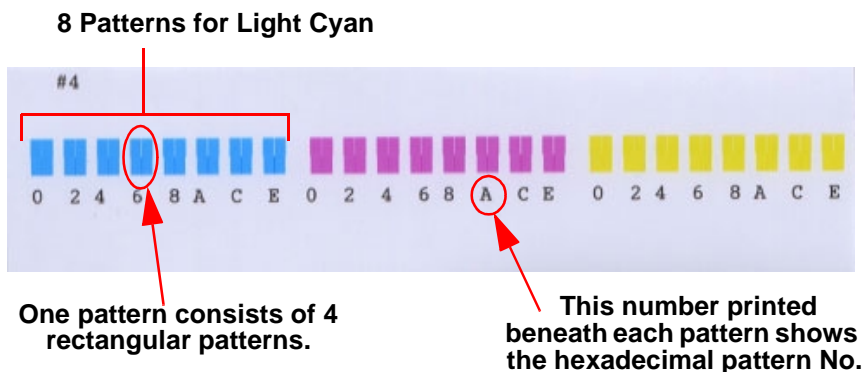

Figure 5-7. Bi-D Adjustment Pattern No. 4

- Each individual pattern consists of 4 rectangular patterns. Search for the pattern among the 8 patterns in each color where there is no gap and no overlapping between these 4 rectangles.

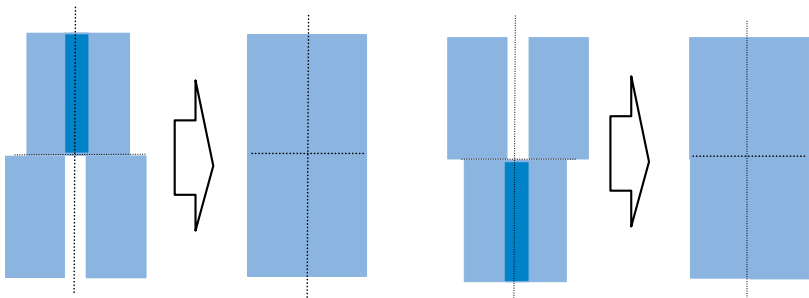

Figure 5-8. Bi-D Adjustment Pattern No. 4 Check Method

7. If you can confirm a pattern among the 8 patterns of each color where there is no gap and no overlapping between these 4 rectangles, press the Paper Source button and move to the adjustment menu for each color. Proceed to Step 12.

If you were unable to confirm an appropriate pattern among the 8 patterns printed in each color, use the Paper Feed + / - buttons to input an estimated value in the “ND Base Value Adjust xx” menu.

- Paper Feed + Button: Moves the top 2 out of the 4 patterns within the printed pattern in a direction so that they separate.
- Paper Feed - Button: Moves the bottom 2 out of the 4 patterns within the printed pattern in a direction so that they separate.

Input the estimated values in the “ND Base Value Adjust xx” Menu, then press the Enter button to print a new Bi-D No. 4 print pattern.

8. Repeat the above steps 6 and 7 until the proper printing pattern can be confirmed.
9. “ND LC: XX” will be displayed in the LCD. In this menu, input the pattern No. of the pattern among the 8 light cyan printed patterns which was confirmed to be proper using the Paper Feed + and - buttons. The pattern No. on the printed pattern has the numbers printed in hexadecimal, with each number increased by 2 from the number of the pattern to its left, but in this menu, it is possible to input each of the 16 numbers, from 0<H> to F<H>, in hexadecimal. After inputting a value, press the Enter button.
10. “ND LM: XX” will be displayed in the LCD. In this menu, input the pattern No. of the pattern among the 8 light cyan printed patterns which was confirmed to be proper using the Paper Feed + and - buttons. The pattern No. on the printed pattern has the numbers printed in hexadecimal, with each number increased by 2 from the number of the pattern to its left, but in this menu, it is possible to input each of the 16 numbers from, 0<H> to F<H>, in hexadecimal. After inputting a value, press the Enter button.
11. “ND Y: XX” will be displayed in the LCD. In this menu, input the pattern No. of the pattern among the 8 light cyan printed patterns which was confirmed to be proper using the Paper Feed + and - buttons. The pattern No. on the printed pattern has the numbers printed in hexadecimal, with each number increased by 2 from the number of the pattern to its left, but in this menu, it is possible to input each of the 16 numbers, from 0<H> to F<H>, in hexadecimal. After inputting a value, press the Enter button.
12. Make sure the message “Bi-D End” is displayed in the LCD, then move to the next adjustment item.

CAUTION

- Up to Bi-D adjustment patterns No. 1 ~ 3, by deciding the value input from the panel, the adjustment results are printed out, so it is possible to check the adjustment results visually, but for Bi-D adjustment pattern No. 4, even if you decide a value to input from the panel, a printing pattern that reflects the adjustment results is not printed, so the adjustment results cannot be checked visually. Therefore, if you are confirming the adjustment results for adjustment values by printing pattern, the following DOS program becomes necessary.

* Program Transfer Utility: Pout3.Exe

* Program Name: Bid333.prn

The program transfer method is as follows.

- 1) Confirm that the printer is in the Pause state.
- 2) Move to the DOS prompt.
- 3) Input "POUT__BID333.PRN."
- 4) Press the Enter key.

Through the above operation, a total of 9 blocks of printing patterns are printed out in each color. The results from the adjustment values input in the Adjustment mode are positioned in the center pattern of the 9-block pattern of each color.



HEAD GAP ADJUSTMENT (ALIGNMENT BETWEEN HEADS)

NOTE: This corrects the printing position between the B and C heads. For adjustment, uni-directional printing is carried out and the print position error is judged in the printing results, then correction values are set. Adjustment items are as follows. The numbers in the above table are printed at the beginning of the printing pattern when the adjustment pattern is printed and show the adjustment pattern No.

Table 5-7. Head Gap Adjustment

		No.
Gap/200/M	Head GAP adjustment / 240 cps / Normal Dot	#5
Gap/300/N	Head GAP adjustment / 333 cps / Normal Dot	#6

1. Make sure "Adj: Head LR Adj" is displayed in the LCD. Press the [Enter] button to print the adjustment patterns.
2. After all the adjustment patterns (#5 and #6) have been printed, "Gap, 200, M: XXX" will be displayed in the LCD.

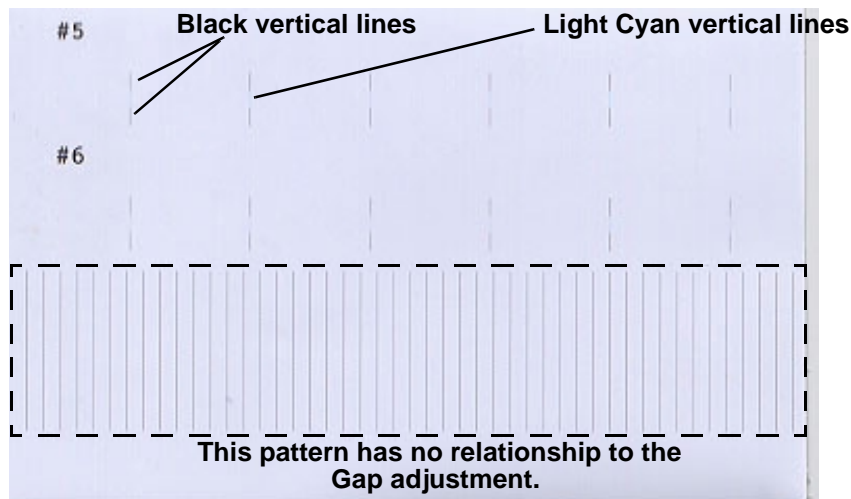

Figure 5-9. Head Gap Adjustment Pattern.

3. Check printing patterns No. 5 and No. 6, and check for deviation of the black vertical lines in the 1st and 3rd pass and in the light cyan vertical lines in the 2nd pass.
 - If there is no deviation in the patterns in printing patterns No. 5 and No. 6, press the Paper Source button 2 times, then check if the message "Gap End." is displayed in the LCD. Proceed to Step 16.
 - If there is deviation in the patterns in printing patterns No. 5 or No. 6, press the Paper Type button to move to the corresponding pattern adjustment menu, then input the appropriate numerical values using the Paper Feed +/- keys. After inputting the correction value, press the Enter button to print the results of the input correction values. The relationship between the inputs using the Paper Feed +/- buttons and the printing results is as shown below.
 - Adjustment value minimum resolution: 1/2880 Inch
 - Correction Direction: Paper Feed - Button = Moves the black lines in the 1st and 3rd passes toward the HP side. Paper Feed + Button = Moves the light cyan lines in the 2nd pass away from the HP side.
 - Adjustment Target: There should be no deviation in the black lines and the light cyan lines.
4. Repeat the above steps 14 and 15 until the adjustment of patterns No. 5 and No. 6 is completed.
5. After confirming that "GAP End." is displayed in the LCD, proceed to the next adjustment item.

FLUSH POINT RIGHT AND LEFT ADJUSTMENT

This function corrects the flushing position of the carriage to make sure the carriage is properly positioned over the F Box R/L during the flushing operation.

1. Make sure "Adj. Flush Point x" ("x" = R or L) appears in the LCD, and press the Enter button.
2. The carriage moves to the flushing position and begins flushing.
3. After flushing is finished, "Point x NNN" ("x" = R or L, NNN = numeric position) appears. Check the piece of paper you put over the flushing box to confirm the ink is ejected into the flushing box. If the ink-flushing position is correct, press the Enter button to finish. Otherwise, press the SelectType or Item button to correct the flushing position. The settings increment as follows.

Correction distance: One press = 1/720 inch

Direction: "+" = toward HP and "-" = away from HP

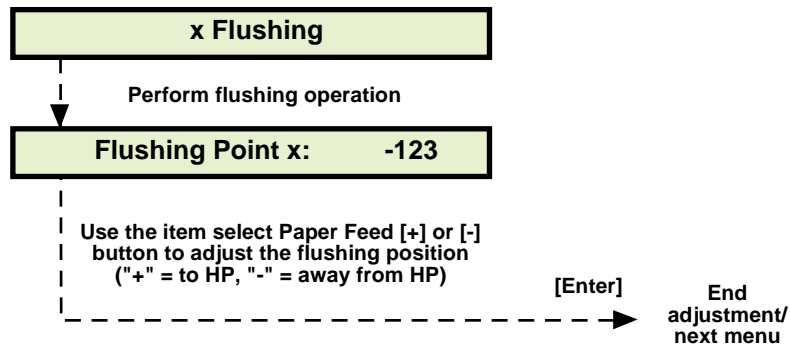

FEED ADJUSTMENT

This function adjusts the distance the printer feeds paper by correcting the printer's distance-measurement setting.

1. Make sure "Adj. Feed" appears in the LCD, and press the Enter button.
2. The printer prints a check pattern (lines) while feeding the paper at a fixed distance.
3. After the pattern is printed, "V Length 1000.0mm" appears. Using a regular ruler (or a Scale Stopper, code number 1047746/1047745), measure the printed pattern from the top line to the bottom line. Then enter this measurement using the item select +/- buttons in 0.1mm increments.
4. After entering the measurement, press the Enter button to finish.

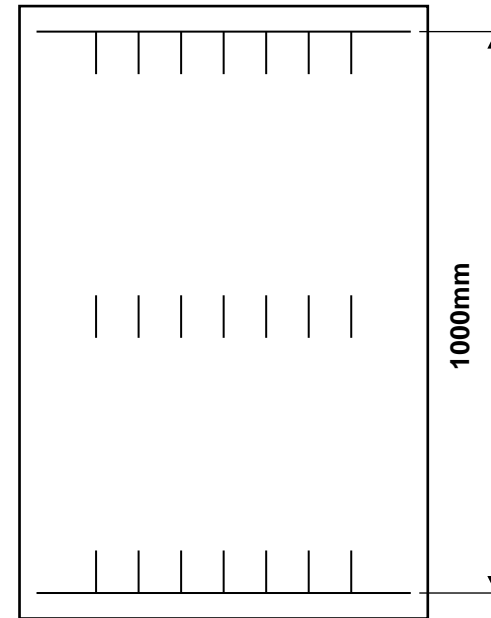
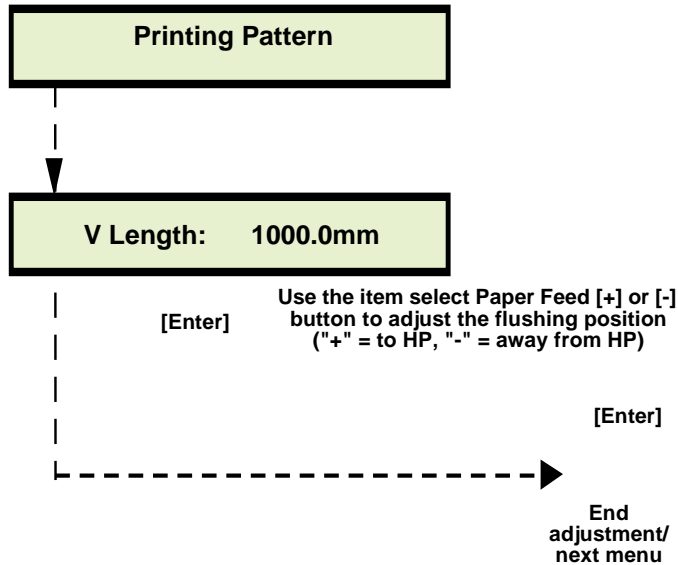

Figure 5-10. Feed Distance Check Pattern



The printed pattern in the middle of the above patterns have the meaning of providing auxiliary lines for applying the ruler.

ADJ TOP & BOTTOM

This function sets the distance between the P FRONT sensor/heads, cutter/heads, and P EDGE sensor/heads as well as adjusts the top, bottom, and side margins. You can also use this function to adjust the top, bottom, and side margins.

1. Make sure "Adj. Top & Bottom" appears, and press the Enter button.
2. Carry out printing of the check pattern and cut the paper at the proper position. At this time, also carry out the operation with the panel's auto cut setting Off.
3. After the printing operation is finished, measure the top, bottom, and right (HP) side margins using a ruler. Press the item select (Paper Feed) +/- buttons to enter each of these measurements in 0.1mm increments when prompted.
4. After entering the measurements, press the SelecType or Item button until "Bottom Length xx.xmm" appears, and then press the Enter button.

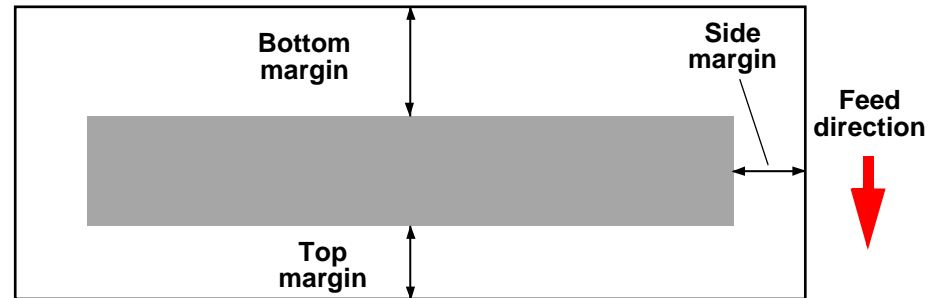
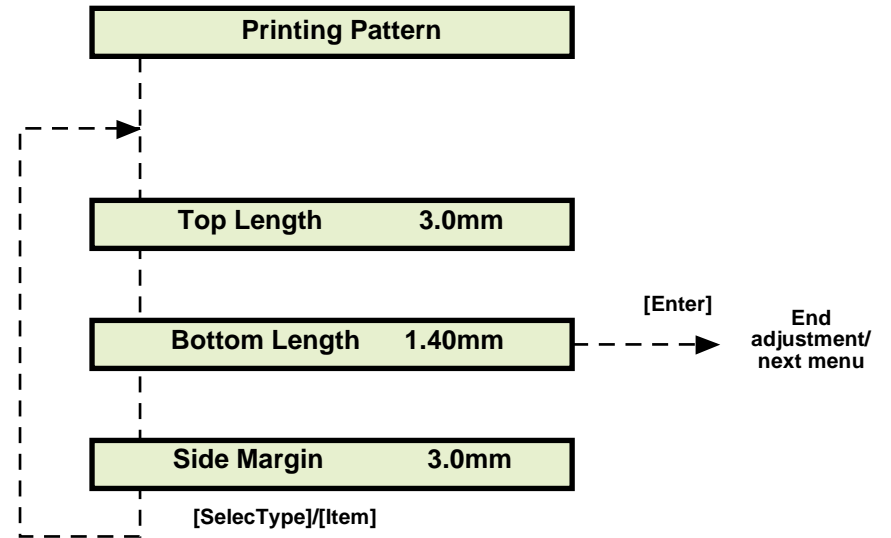

Figure 5-11. Measuring Sections/Margin Adjustment Pattern

ADJ REAR SENSOR POSITION

This function makes sure the P REAR sensor correctly detects the rear edge of cut-sheet paper to allow the user to print with the largest possible printable area but without printing off the edge of the paper and marring future printouts. The printer prints an A3-size test pattern. Using a ruler, measure the distance from the rear edge of the pattern to the rear edge of the paper, and then enter this measurement when prompted. This value is stored in the printer's firmware to be referenced against the printhead nozzle position.

NOTE: This adjustment is for the purpose of detecting the edges of cut sheet paper. This is because this item could not be detected in the top and bottom detection in the previous item.

1. Make sure "Adj Rear Sensor Pos." appears, and press the Enter button.
2. Load A3-size paper in portrait (short edge first) orientation when you see the "Please Set CutSheet" message. After the paper initializes, press the Enter button to print the check pattern.
3. After printing is finished, measure the distance from the rear edge of the printed pattern to the rear edge of the paper. Press the SelectType or Item button until you see "RearSen. Pos. xx.xmm", and then enter the measurement in increments of 0.1mm using the item select (Paper Feed) +/- buttons.

4. After entering the measurement, press the Enter button.

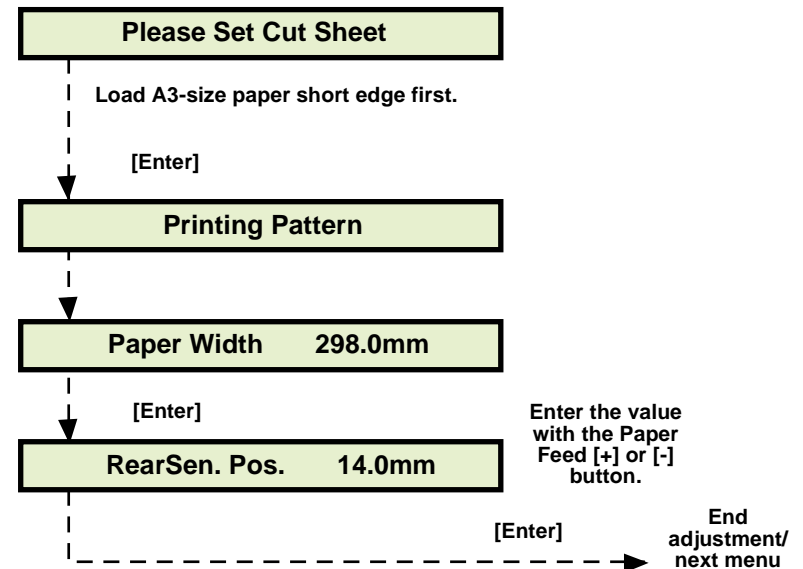

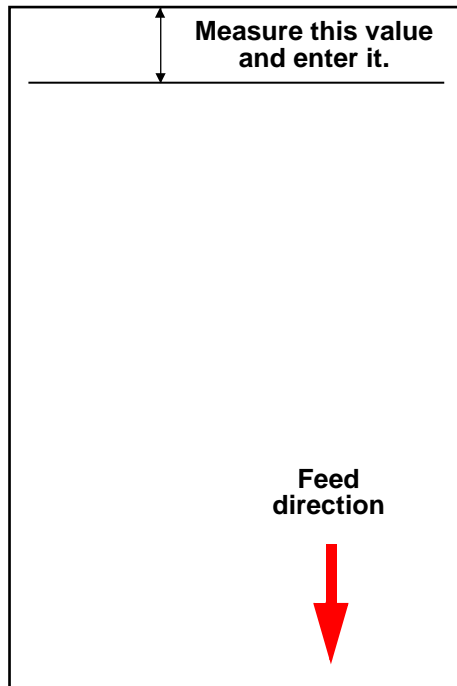

Figure 5-12. Rear Sensor Position Adjustment/Measurement

TEST PATTERN PRINT

This function prints a test pattern plus certain printer information/settings that you can refer to when performing printer adjustment procedures. For a list of the information that is printed, see the following table.

Table 5-8. Printed Items in the Test Pattern

Item	Description
Nozzle Check	Prints all of the check/test patterns that are available from the "Adjustment" menu.
Adjustment Variables	Prints a list of all the adjustable items from the "Adjustment" menu.

To print the list of variable items you need to enter the printer's serial number when prompted. The serial number is located on the back of the printer, next to the power connector.

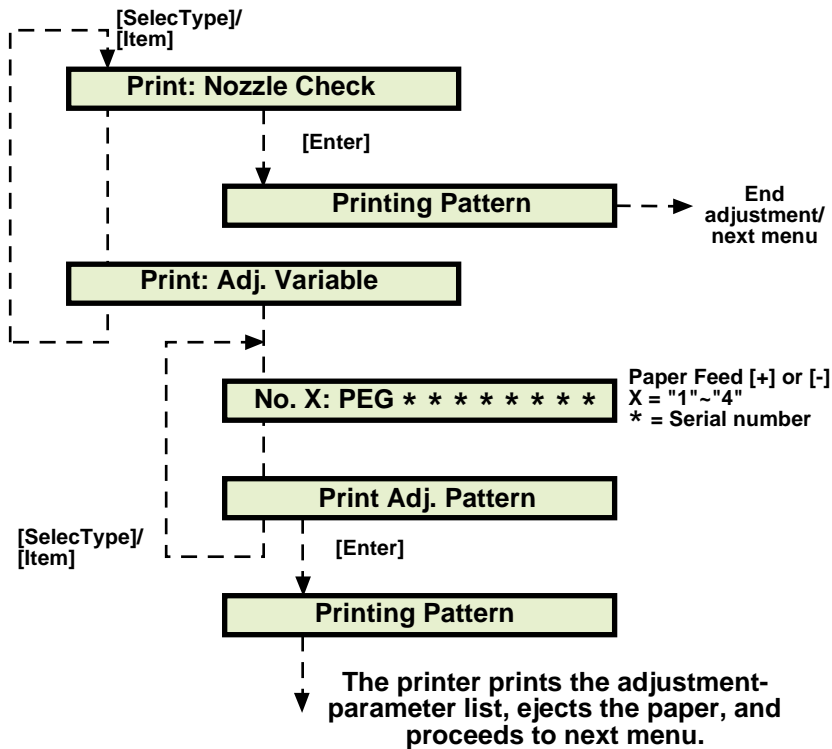

CLEAN HEAD (DRAIN INK)

This function allows you to drain the ink from the ink delivery system including the printheads. Perform the Clean Head function before moving the printer.

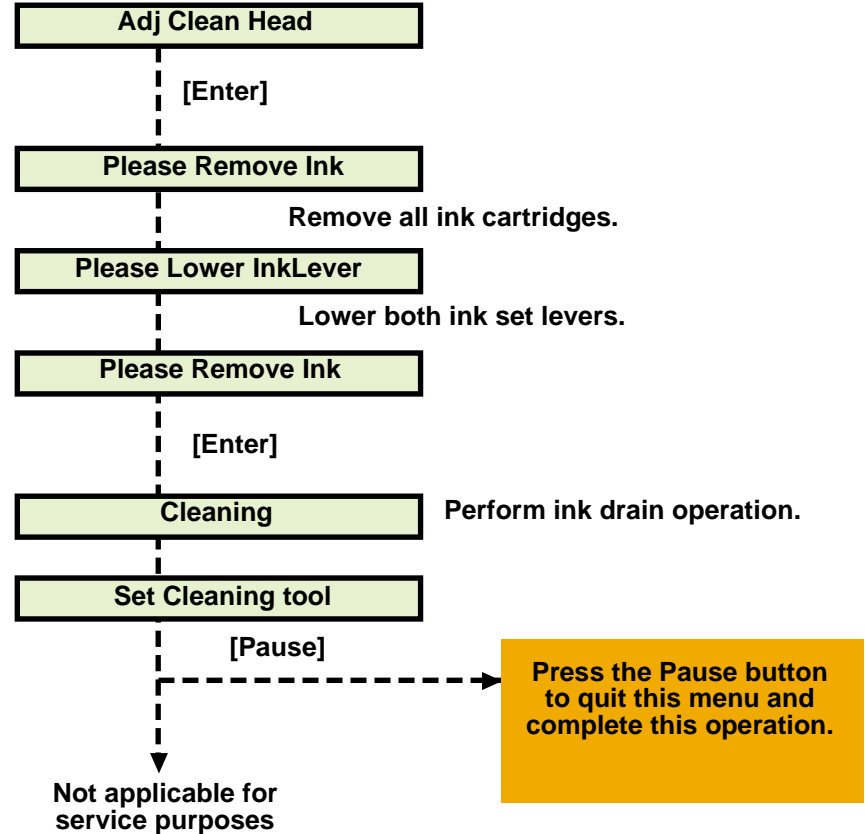



- The waste ink pads' condition should be checked in advance, then if it is judged that their remaining capacity is low, they should be replaced with new ones after this operation is completed.
- If this product is transported again or moved after installation, ink discharge should also be carried out in this function.
- After ink discharge, at the point when the necessary operation is completed, be sure to carry out "Initial Filling." (See item 5.3.4.)

COUNTER CLEAR

This function resets (to the original condition) the following counters which are stored in memory on the Main Board.

Table 5-9. Counters Reset by "Counter Clear"

Counter	Reset Value
Protection Counter A/B	0
Ink Volume Counter Rb/ Ry/ Rx Rz	0
Consumed Ink Counter Cb/ Cy/ Cm/ Cc/ Cml/ Ccl	0
Power Cutoff Timer T2	0
Accumulated Prints Timer	0
CL Timer	0
CL Timer 3	0
CL Flag	0
Initial Charge Flag	1*
Periodic Pseudo-Vacuum Flag	0

Note *: "1" means the flag is set, and the next time power is turned on the printer will perform an initial ink charge.

CAUTION

Since the counter for the remaining ink holding capacity of the waste ink pads and the ink consumption counter, etc. are cleared by this function, if the counters have been cleared, all the affected parts (waste ink pads, ink cartridges) should be replaced with new ones.

5.2.5 Test Menu

The Test menu tests or checks the operation of the control circuit board.



This menu is also used for operation checks of each of the sensors, etc. in Chapter 3, "Troubleshooting."

Table 5-10. Test Menu Items

Test Item	Description
Version	<input type="checkbox"/> Program <input type="checkbox"/> Backup parameters <input type="checkbox"/> DIP-SW <input type="checkbox"/> Board Rev.
Control Panel	<input type="checkbox"/> Panel buttons <input type="checkbox"/> LCD panel display <input type="checkbox"/> LED indicators
Sensors	HP, Cover Open, Release Lever, P_FRONT, P_Rear, Paper Thickness, PG, Thermistor, I/C Holder Levers, Ink ID, I/C, and Ink Low
Encoder	CR Motor, PF Motor
Fan	On/Off confirmation
Elec.	<input type="checkbox"/> Maintenance Record <input type="checkbox"/> Fatal Error Record
D/A Revision	Factory use for Head voltage correction - do not attempt
Head Signal	Factory use for Head pulse check - do not attempt

NOTE: The D/A correction in the above table should not be implemented.

The menu items and their order in the menu are shown below.

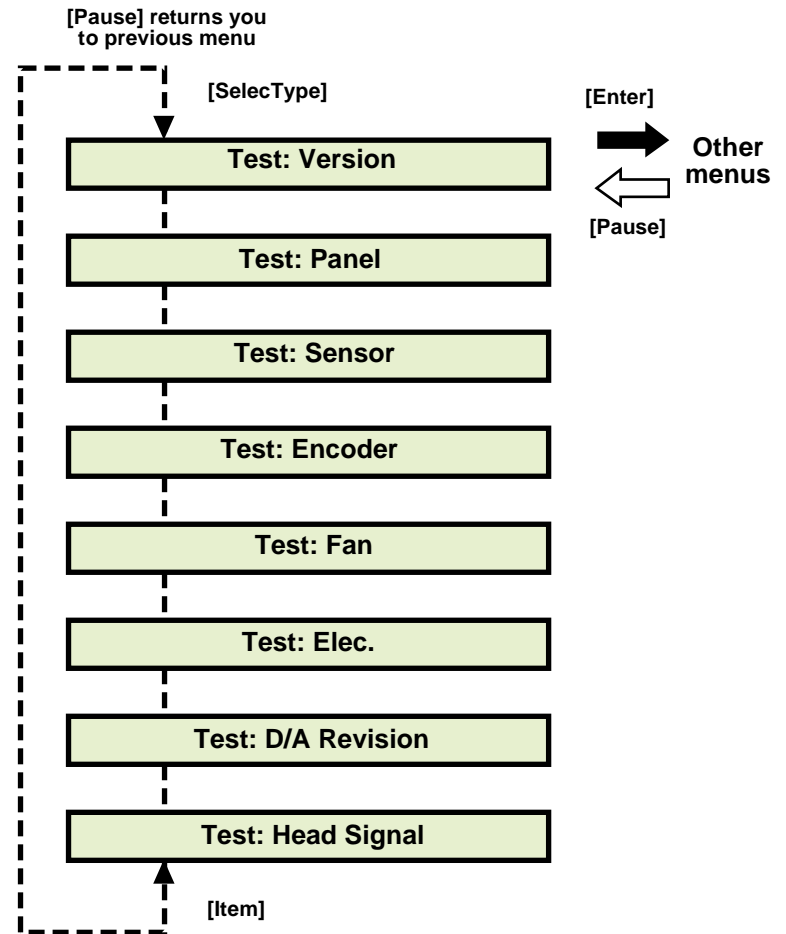

VERSION

This function confirms the firmware version and dip switch settings.

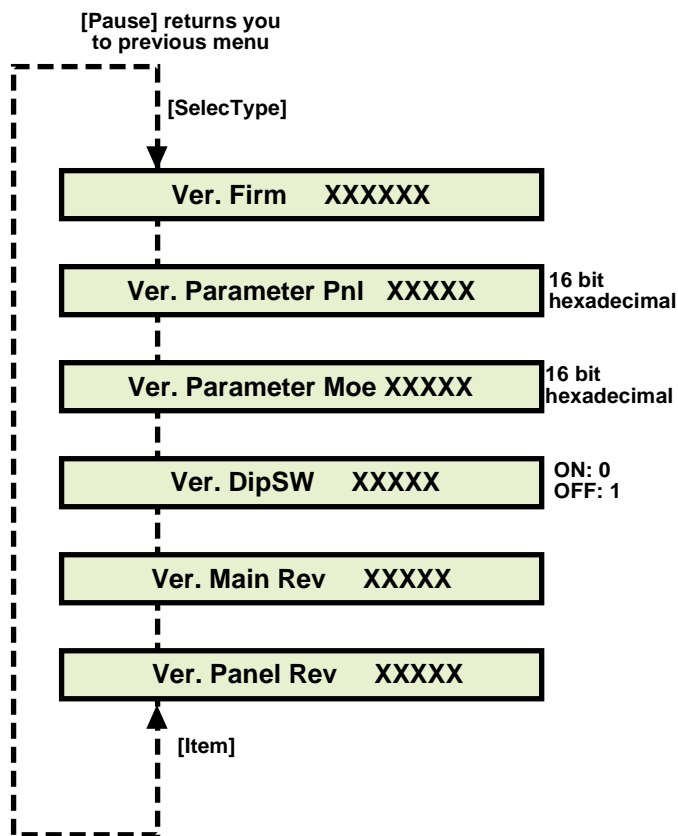

NOTE: The Dip switch

The dip switch located on the Main Board is a 2-bit switch, SW-1 is LSB (Least Significant Bit) and SW-2 is MSB (Most Significant Bit). For example, if SW-1 = Off and SW-2 = On, the LCD will display "Ver. DipSW 0x01".

CONTROL PANEL

This function allows you to check the operation of the control panel buttons, LED indicators, and LCD panel.

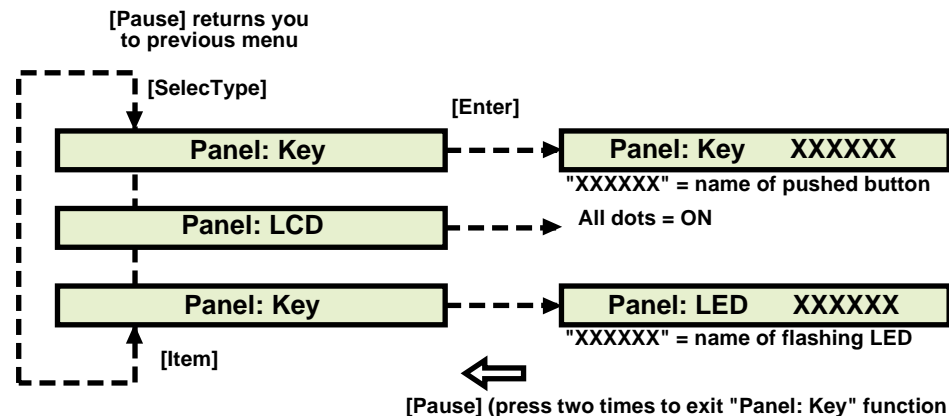

- "Key" check
The name of the button that is pressed appears. Press the [Pause] button twice to exit the "Panel: Key" function.
- "LCD" check
All dots turn on. If a dot is not on, the LCD is not working properly.
- "LED" check
The LED indicators turn on in the following order and the name of the indicator appears in the LCD when it turns on.
Power, Pause, Ink End (K, C, Lc, M, Lm, and Y), Paper Out, Roll Auto Cut, Roll Cut Off, and Sheet

SENSORS

This function allows you to confirm the sensors are operating properly. The current status (ON or OFF) of the sensors (one at a time) is shown in the LCD display, and you need to check the sensor operation by hand. For example, to check the Release Lever position sensor, move the lever up and down.

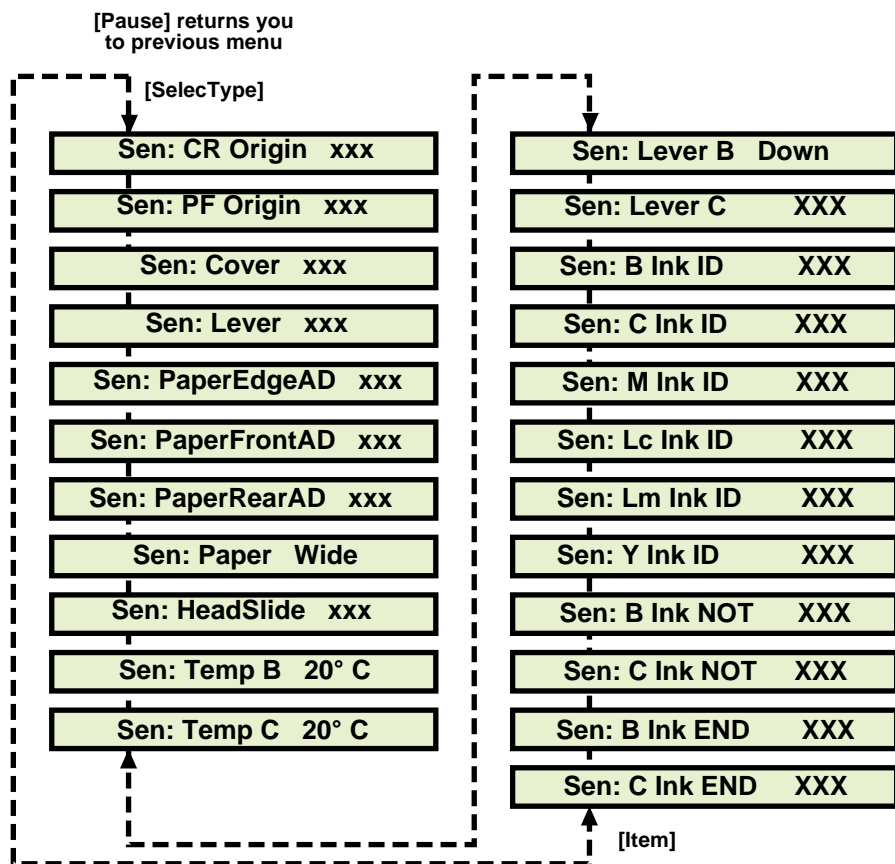

Table 5-11. “Sensor” Function Confirmation Items
Table 5-12.

Display Item	Contents
CR Home Position	Shows the state detected by the HP sensor.
PF Home Position	(Not used.)
Cover	Shows the front cover open / closed state.
Lever	Shows the paper release lever’s state (Lock/Release).
Paper Edge AD / Paper Front AD / Paper Rear AD”	Shows the state detected by the paper sensors’ (P_EDGE, P_FRONT, P_REAR).
Paper Thickness	Shows the state detected by the paper thickness detection sensor.
Head Slide	Shows the state detected by the PG cam home position detection sensor.
Temperature B / C	Shows the temperature detected by the Thermistor inside the B and C heads.
Ink Lever B / C	Shows the I/H holder lever position detection state.
Ink ID	Shows the detection state of the ID sensors inside the I/C holder of each color, and displays it as the 0 ~ 7 value. If the sensor is ON, a 1 is displayed, and if it is OFF, a 0 is displayed.
B / C Ink NOT	Shows the state detected by the I/C sensor, whether the I/C is present or not, and displays the name of the I/C that is not installed. (Example: When the Lm I/C is not installed, “Lm” is displayed.)
B / C Ink END	Shows the state detected by the ink low detection sensor and shows the name of the I/C where the ink low state is detected.



When replacing the circuit board, or when replacing the P_THICK, P_REAR or P_FRONT sensor, the following adjustment should be made.

- **Sensor Adjustment (See the next page.)**

SENSOR ADJUSTMENTS

The P_EDGE, P_REAR and P_FRONT sensors which detect the paper are reflective type optical sensors, so if the sensors themselves and the main board are replaced, the following adjustment should be made to set the sensors' detection level to the proper value.



- For the reasons given on the preceding page, depending on the base unit's serial code and the firmware version, the adjustment methods for the P_FRONT / REAR / EDGE sensors differ, so the appropriate adjustment should be made.
- If the same sensor adjustment as that for a Type 2 unit is performed for a Type 1 unit, the sensor's sensitivity will rise too high and it will be easy for it to be influenced by stray light, and it may no longer be impossible for it to correctly detect EPSON genuine paper.
- If you are turning the VR1, VR2 and VR3 volume resistors on the main board to make adjustments, care should be taken not to touch the other elements on the board or the frame, etc. It is recommended that a screwdriver that is not conductive be used for this adjustment.
- It is easy for each sensor to be influenced by stray light from the sun or from the room lighting, etc. The P-FRONT sensor in particular is easily influenced by stray light, so printing should always be done with the printer covers securely in place.
- If the specified paper is set in the printer for each sensor adjustment, the paper set lever should be moved to the paper set position securely so as to stabilize the paper over the sensors.
- The papers used for this adjustment (PPC, Kimoto Tracing Paper #300) should be replaced periodically. If there is any dirt (ink, foreign matter adhering), damage (wrinkles, tearing) in the standard paper, an accurate adjustment cannot be made, so the standard paper should be replaced after adjustment of about 20 printer units.



Since the new pigment based firmware is written to the flash ROM by this upgrade service implementation, the display in the sensor adjustment mode's LCD display is as shown below. The meaning of each value is also shown below.

Panel Display: "Sen: Sensor Name A D ttt vvv"

ttt = Difference between the sensing level when there is no paper and when there is paper. This numerical value is shown in Hexadecimal and changes depending on the printer's state.

vvv = Sensor detection level when there is paper.

The hexadecimal number during the adjustment changes depending on the VR element's adjustment level and the printer's state.

The mounting location of each sensor adjustment VR element on the Main board is as shown in the following figure.

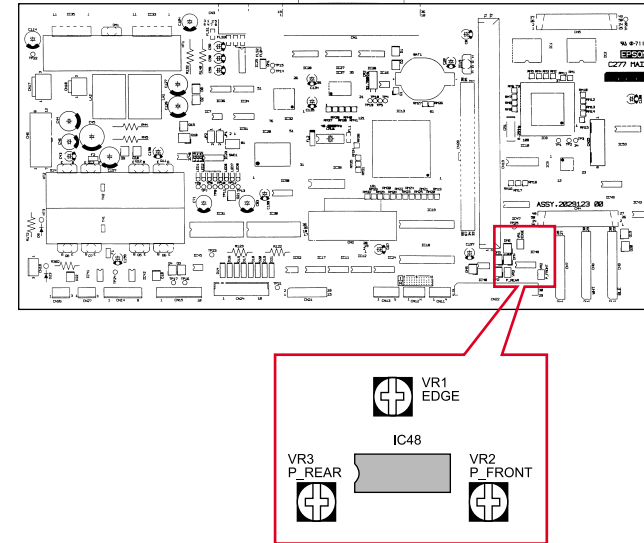

Range which is visible when the paper guide U access cover is open.

Figure 5-13.

The function of each VR element is as shown in the table below.

Table 5-13. VR Element Function

sensor	VR element
P-EDGE Sensor	VR1
P-FRONT Sensor	VR2
P-REAR Sensor	VR3

□ **P_EDGE Sensor Adjustment**

1. The self-diagnostic mode is started by turning on the Power switch while pressing the following buttons.
 - Paper Feed – Button + Cut / Eject Button + Cleaning Button

Press the Paper Source button and select "Check: Test", then press the Enter button.

2. Press the Paper Source button and select "Test : Sensor", then press the Enter button.
3. Press the Paper Source button and select "Sen: Edge AD." At that time, make sure that the LCD displays "Sensors: Edge AD ttt vvv."

NOTE: "ttt" or "vvv" is a hexadecimal number that changes depending on the printer's state.

4. As necessary, the access cover on the paper guide should be removed.
5. Raise the paper set lever, then set a sheet of A3 size plain copy paper in the paper path, then lower the paper set lever to fix the paper in position. At this time, make sure the front edge of the sheet of paper is at the paper front edge setting position on paper guide L.
6. Move the CR unit over the paper and close the front cover halfway. At this time, if the vvv value in the LCD display does not change, the subsequent operation can be performed with the front cover in the open state. If the vvv value changes, use adhesive tape, etc. to fix the front cover in the half closed state.

NOTE: Move the CR unit over the paper so that the CR unit's right edge is aligned with the paper's right edge.

7. Confirm that the LCD displays the following.
 - LCD Display: "Sen: Edge AD ttt vvv"
 - ttt value: 040<H> or higher
 - vvv value: Should be a value between 0E0<H> and 0E8<H>.

If the ttt value is lower than 040<H>, adjust the VR1 element gradually. If the VR1 element is set on the maximum, and vvv does not reach 0E0<H>, adjust the VR1 element so that the sensor detection level when there is no paper rises, adjusting it so that it reaches 0E0<H> when paper is present. If adjustment is impossible, replace the sensor.
8. Raise the paper set lever, then after removing the paper, return the paper set lever to the paper set position.

□ P_FRONT Sensor Adjustment

1. Press the Paper Source button and select "Sen: Front AD." At that time, make sure that the LCD displays "Sen: Front AD ttt vvv." If the vvv value is lower than 01C<H> when no paper is set, then adjustment is impossible. In this case, replace the sensor.

NOTE: "ttt" or "vvv" is a hexadecimal number that changes depending on the printer's state.

2. Raise the paper set lever, then set a sheet of #F751 Kimoto Micro Tracing Paper (A3 size) in the paper path, then lower the paper set lever to fix the paper in position. At this time, make sure the front edge of the sheet of paper is at the paper front edge setting position on paper guide L.
3. Close the front cover halfway. At this time, if the vvv value in the LCD display does not change, the subsequent operation can be performed with the front cover in the open state. If the vvv value changes, use adhesive tape, etc. to fix the front cover in the half closed state.
4. Confirm that the LCD displays the following.
 - LCD Display: "Sen: Front AD ttt vvv"
 - ttt value: 40<H> or higher
 - vvv value: 95<H> or lower

If the above conditions are not met, adjust the VR2 element gradually while checking the display in the LCD, adjusting the values so they match the above conditions.

□ P_REAR Sensor Adjustment

1. Press the Paper Source button and select "Sen: Rear AD." At that time, make sure that the LCD displays "Sen: Rear AD ttt vvv." If the vvv value is lower than 01C<H> when no paper is set, then adjustment is impossible. In this case, replace the sensor.

NOTE: "ttt" or "vvv" is a hexadecimal number that changes depending on the printer's state.

2. Raise the paper set lever, then set a sheet of #F751 Kimoto Micro Tracing Paper (A3 size) A3 in the paper path, then lower the paper set lever to fix the paper in position. At this time, make sure the front edge of the sheet of paper is at the paper front edge setting position on paper guide L.
3. Close the front cover halfway. At this time, if the vvv value in the LCD display does not change, the subsequent operation can be performed with the front cover in the open state. If the vvv value changes, use adhesive tape, etc. to fix the front cover in the half closed state.
4. Confirm that the LCD displays the following.
 - LCD Display: "Sen: Rear AD ttt vv"
 - ttt value: 40<H> or higher
 - vv value: 95<H> or lower

If the above conditions are not met, adjust the VR3 element while checking the display in the LCD and adjusting the values so they match the above conditions.

5. Raise the paper set lever, then after removing the paper, return the paper set lever to the paper set position.
6. Turn the printer's power switch off, then close the access cover and tighten the installation screws.

ENCODER

This function confirms the operation of the CR Motor and PF Motor encoders.

To check, with the affected sensor in the selected state, you can move the following parts manually and confirm that the sensor's detection state (encoder output conversion value) is displayed.

- CR encoder: Move the carriage left and right by hand
- PF encoder: Turn the Grid Roller by hand

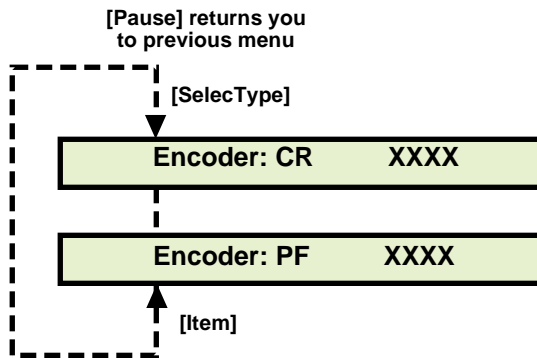

FAN

This function confirms the operation of the paper vacuum fans. When this item is selected, the fan turns on. Press the Pause button to turn the fan off and proceed to the next item.

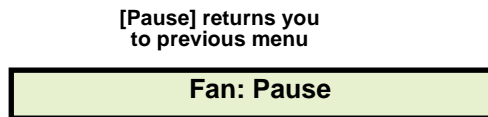

ELEC.

This function allows you to check the operation-record information and the fatal-error record stored in the control circuit.

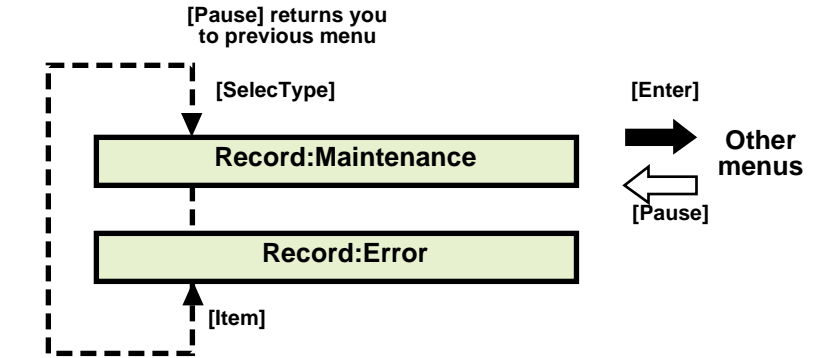

- Record: Error menu

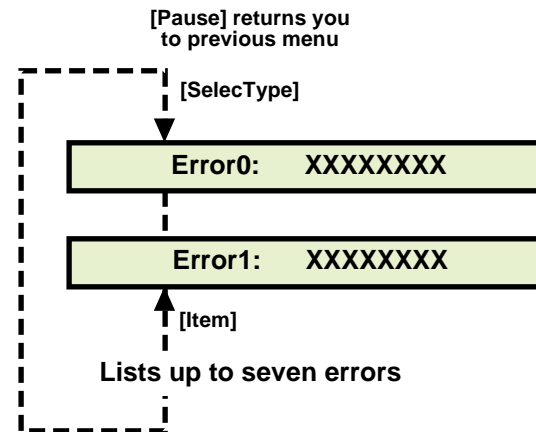

The errors listed here do not include CPU errors (service call errors), and the printer lists a maximum of the most recent seven fatal errors, Error 0~6.

□ Record: Maintenance menu

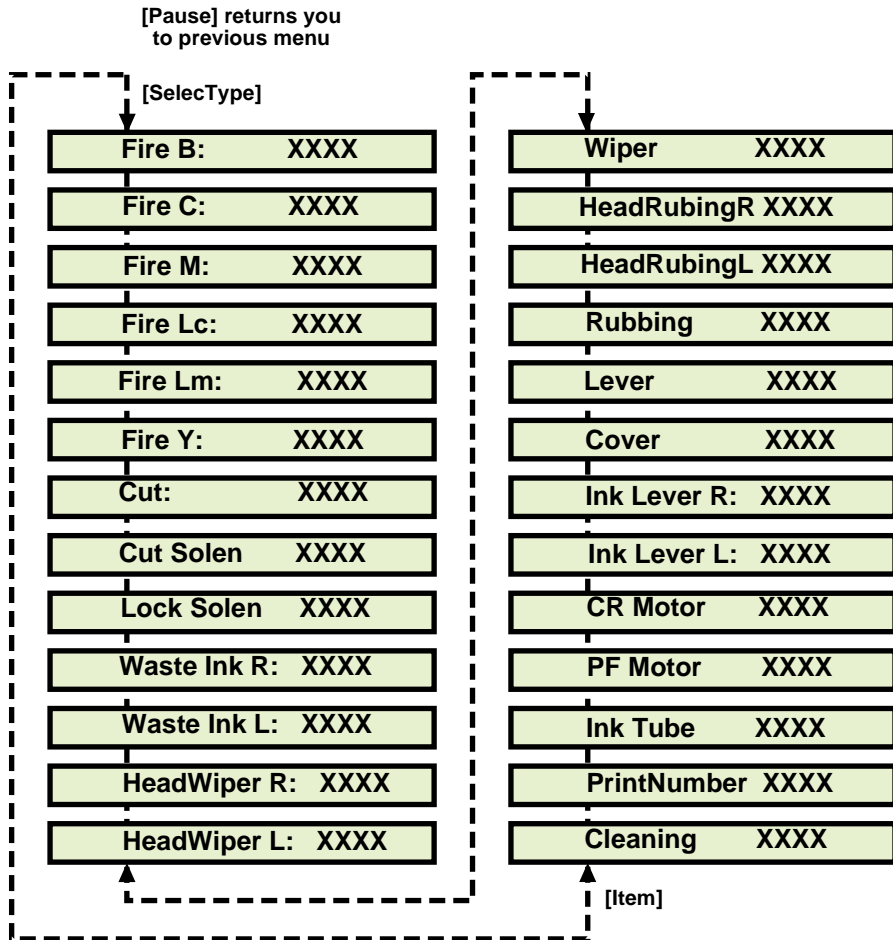

Table 5-14. Maintenance Record Items

Item	Description
Fire x	Amount of ink fired from nozzles in number of megadots (x = which color)
Cut	Number of times cutter has been used
Cutter Solenoid	Number of times cutter solenoid has operated
Lock Solenoid	Number of times CR lock solenoid has been used
Waste Ink R/L	Amount of waste ink (right or left)
Head Wiper R/L	Number of times head wiping operation has occurred
Wiper	Number of times wiper has been used
Head Rubbing R/L	Number of times B/C head rubbing operation has occurred
Rubbing	Number of times rubbing pad has been used
Lever	Number of times paper has been set (up and down = one time)
Cover	Number of times front cover has been opened (open and close = one time)
Ink Lever R/L	Number of times I/C Holder has been opened (open and close = one time)
CR Motor	Accumulated travel distance of carriage (in Km)
PF Motor	Accumulated travel distance of paper feed mechanism (in Km)
Ink Tubes	Accumulated Number of Carriage Passes
Print Number	Accumulated printout count (each Form-Feed code = one printout)
Cleaning	Accumulated number of cleaning operations

"UPDATE" ITEMS

The items you can update are described below.



The parameters will update and be stored in the Flash memory on the Main Board the next time the printer is turned off.

- Capping Position (See page xx)
- Head Rank (See page xx)
- Print Position Items (Bi-D Adjustment/Gap Adjustment) (See page xx)
- Paper Feed Distance (See page xx)
- Mechanical Parameters (See page 182.)

Update concerning the R and L flushing positions, and the top, bottom, side and rear margins.

- Ink Parameters

By using this function, the initial filling flag can be set as desired. ("Set" = Execution of the initial filling sequence the next time the power is turned on.)

- Dot Shift Mode

This mode sets an offset for the adjustment value in Bi-D adjustment pattern No. 4. The initial setting is "Single Print."



If "Pair" is set based on the evaluation results, it will be judged that there is shifting of the adjustment results in the (Inter row corrections) in Bi-D No. 4, so the setting should absolutely not be changed in servicing.

If you change the setting, it will cause color irregularity (vertical direction), so adequate caution should be taken.

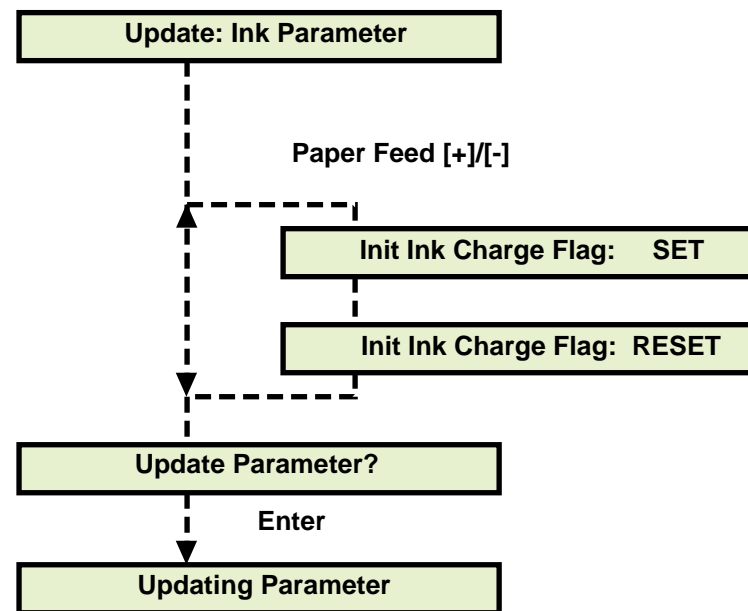

5.2.8 Maintenance Mode

MAINTENANCE MODE

- Start Button: Turn the Power switch On while pressing the "Pause" button.
- Setting Item Selection: "Paper Source" Button
- Changing Setting Values: "Setting Value +" or "Setting Value -" Button
- Setting the Set Values: "Enter" Button
- Setting End: Power ON/OFF
- Power-on button: Pause

Note 1): Settings with underlines in the table show default values.

Note 2): During HEX dump execution, the message "HEX MODE" is displayed.

Note 3): If you are using the Stylus Pro 7000 to print in the single color mode at 720 x 720 dpi, if banding is prominent, selecting this mode may possibly reduce banding.

Message	Item	Explanation
HEX DUMP	PRINT	This prints out print data transferred to the printer in hexadecimal form. 16 data items per line are displayed and in addition, an ASCII character corresponding to those data is printed on the right side. If there are no characters, such as print or control codes, which correspond to the data, a "." (period) is printed. The panel settings cannot be set while the printer is in this mode. To end this function, first stop printing by operating the Pause button, then turn the power switch off.
LANGUAGE	ENGLISH FRENCH ITALIAN GERMAN SPANISH PORTUGUE	The language displayed in the LCD screen can be select English, French, Italian, German, Spanish, Portuguese.
MW7	A B	This selects M/W operation in the 720 x 720 dpi mode. A is the operating mode that reduces banding in Bi-D printing. B is the Stylus Pro 9000 / 7000 720 dpi x 720 dpi interchangeable operating mode.

MAINTENANCE MODE 2

- Start Button: Turn the Power switch On while pressing the following panel buttons to start.
 - “Paper Source Button” + “Cut / Eject Button” + “Paper Feed – Button”
- Setting Item Selection: “Paper Source” Button
- Changing Setting Values: “Setting Value +” or “Setting Value –” Button
- Setting the Set Values: “Enter” Button
- Setting End: Power ON/OFF

This mode can be roughly divided into the following 3 items.

Table 5-15. Maintenance Mode 2 Setting Items

Item	Panel Display
Counter Display Menu	VIEW COUNTERS MENU
Counter Initialization Menu	CLEAR COUNTERS MENU
Adjustment, Setting Menu	SERVICE CONFIG MENU

For each major item, see the following page.

- Counter Display Menu

The items displayed in the Maintenance Mode 2 “Counter Display Menu” are shown below.

Table 5-16. Counter Display Menu

Item	Panel Display	Setting Value
Remaining Ink (K) counter Value Display	INK K	0~4294967295 (Decimal number)
Remaining Ink (C) counter Value Display	INK C	0~4294967295 (Decimal number)
Remaining Ink (M) counter Value Display	INK M	0~4294967295 (Decimal number)
Remaining Ink (LC) counter Value Display	INK LC	0~4294967295 (Decimal number)

Table 5-16. Counter Display Menu

Item	Panel Display	Setting Value
Remaining Ink (LM) counter Value Display	INK LM	0~4294967295 (Decimal number)
Remaining Ink (Y) counter Value Display	INK Y	0~4294967295 (Decimal number)
Cutter Life Counter Value Display	CUTTER	0~4294967295 (Decimal number)
Total Printed Sheet Counter Value Display	TTL PAGES	0~4294967295 (Decimal number)
Waste Ink Counter A Value Display	WAST INKA	0~4294967295 (Decimal number)
Waste Ink Counter B Value Display	WAST INK B	0~4294967295 (Decimal number)
CR Motor Service Life Counter Value Display	CR MOTOR	0~4294967295 (Decimal number)
PF Motor Service Life Counter Value Display	PF MOTOR	0~4294967295 (Decimal number)
Head Unit (K) Service Life Counter Value Display	HEAD K	0~4294967295 (Decimal number)
Head Unit (C) Service Life Counter Value Display	HEAD C	0~4294967295 (Decimal number)
Head Unit (M) Service Life Counter Value Display	HEAD M	0~4294967295 (Decimal number)
Head Unit (LC) Service Life Counter Value Display	HEAD LC	0~4294967295 (Decimal number)
Head Unit (LM) Service Life Counter Value Display	HEAD LM	0~4294967295 (Decimal number)
Head Unit (Y) Service Life Counter Value Display	HEAD Y	0~4294967295 (Decimal number)
Cleaning Unit Life Counter	CLEANER	0~4294967295 (Decimal number)

□ Counter Initialization Menu

The items that can be initialized in the “Counter Initialization Menu” in Maintenance Mode 2 are shown below.

Table 5-17. Counter Initialization Menu

Item	Panel Display	Setting Value
Initializes NVRAM / Ink System / Mechanism Counters.	INIT.ALL	EXEC.
Initializes NVRAM contents (Panel setting information, Bi-D and Cap Adjustment parameters).	INIT.NVRAM	EXEC.
Timer Setting Value Initialization	INIT.TIMER	EXEC.
CR Motor Service Life Counter Initialization	INIT.CR MTR	EXEC.
PF Motor Service Life Counter Initialization	INIT.PF MTR	EXEC.
Head Unit Service Life Counter Initialization	INIT.HEAD	EXEC.
Cleaning Unit Service Life Counter Initialization	INIT.CLEANER	EXEC.
Total Printed Page Count Counter Initialization	INIT.TTL PR	EXEC.
Ink Level Counter Initialization	INIT.INK	EXEC.
Waste Ink Capacity Counter Initialization	INIT.WA INK	EXEC.

□ Adjustment Menu

The items that can be initialized in the Counter Initialization Menu in Maintenance Mode 2 are shown below.

Table 1-35 List of Adjustment Menu Items

Table 5-18.

Item	Panel Display	Setting Value
Right Head Bi-D Offset Setting#1 (Normal dot) Note 2)	BID OFFSET #1	-4~0~4
Ink Level Detection Note 3)	DET.ECT INK LABEL	ON OFF
MW 2 Feed Balance Note 4)	MW 7 BALANCE	-31~0~+31

Note 1): Settings with underlines show default values.

Note 2): This sets the desired offset the adjustment value in Bi-D Adjustment Pattern #3, set by the user. This mode is a function for reducing irregular color that occurs in the 720 dpi x 720 dpi and 1440 dpi x 720 dpi printing modes due to setting of the desired offset with respect to the adjustment values for Bi-D adjustment values (Bi-D adjustment pattern No. #3) for these printing modes. However, since there are cases where there is no effect even when the desired offset is set in this function, adequate caution should be exercised when changing the setting values.

Note 3): This sets whether the sensor which detects the I/C type identifier on the I/C label will detect it or not.

Note 4): If microbanding, which occurs in the 720 x 360 dpi mode and the 720 x 720 dpi mode actually occurs, this reduction function acts to reduce banding somewhat when this setting is changed. However, there may not be any effect even if the setting is set in the desired value by this function, so exercise caution when changing the setting value.

5.2.9 Mechanism Adjustment

This section describes the mechanism adjustments you need to perform when replacing or removing certain parts. The parts and their corresponding adjustments are as follows.

Table 5-19. Necessary Mechanism Adjustments

Parts	Adjustment	Necessary Tools	Refer to
<input type="checkbox"/> Printhead <input type="checkbox"/> Ink Damper Assembly <input type="checkbox"/> Cutter solenoid <input type="checkbox"/> Carriage cover	<input type="checkbox"/> Cutter installation position adjustment. <input type="checkbox"/> Carriage cover height	<input type="checkbox"/> Cutter installation position adjustment tool #F759 Code: 1059443 <input type="checkbox"/> CR Cover Position Adjustment Tool #F724 code: 1049975	page 205 page 208
CR Motor	CR Steel Belt Tension	<input type="checkbox"/> Tension Gauge #F712 code: 1047744 Standard: 200g	page 213
PF Motor	PF Belt Tension	<input type="checkbox"/> Tension Gauge code: B747700300 Standard: 4000g	page 213
PG Motor	Gear Backlash	confirm by sight	page 214
Lower Paper Guide	<input type="checkbox"/> Paper guide L installation position adjustment <input type="checkbox"/> Cutter Position	<input type="checkbox"/> Paper guide L installation position adjustment tool #F755 Code: 1059434 confirm by sight or by measuring with a ruler	page 204
I/H Assembly	I/H Handle Gear position match	confirm by sight	page 214
P THICK sensor	Self-diagnostic mode test - "Paper Thickness"	-	page 215
CR Encoder Sensor	CR encoder sensor installation position adjustment	<input type="checkbox"/> CR ENC Installation adjustment tool #F766 Code: 1060655	page 210

Table 5-19. Necessary Mechanism Adjustments

Parts	Adjustment	Necessary Tools	Refer to
PF Encoder Sensor	<input type="checkbox"/> PF encoder sensor installation position adjustment <input type="checkbox"/> PF encoder sensor installation position adjustment 2	<input type="checkbox"/> PF ENC installation adjustment tool #764 Code: 1060658 <input type="checkbox"/> PF ENC installation adjustment tool 2 #765 Code: 1060657	page 211 page 211
Cover Open R/L sensor	<input type="checkbox"/> Front cover positioning adjustment <input type="checkbox"/> Self diagnostic mode test - "Cover"	<input type="checkbox"/> Front cover positioning tool #F754 Code: 1059420	page 215

PAPER GUIDE L INSTALLATION POSITION ADJUSTMENT

This adjustment is performed for the following purposes.

- Install the paper guide L so that it is parallel to the PF roller.
 - It goes a long way toward adjusting the paper cutting position accuracy with respect to the cutter level difference in the sub-platen.
1. Loosen the 9 screws used to install the paper guide L, then set tool No. #F755 between paper guide L and the platen on the left side of the printer as shown in the figure below. While pushing the paper guide L toward the sub-platen (upward), tighten the 4 screws on the left side of the paper guide L to fasten it in place.

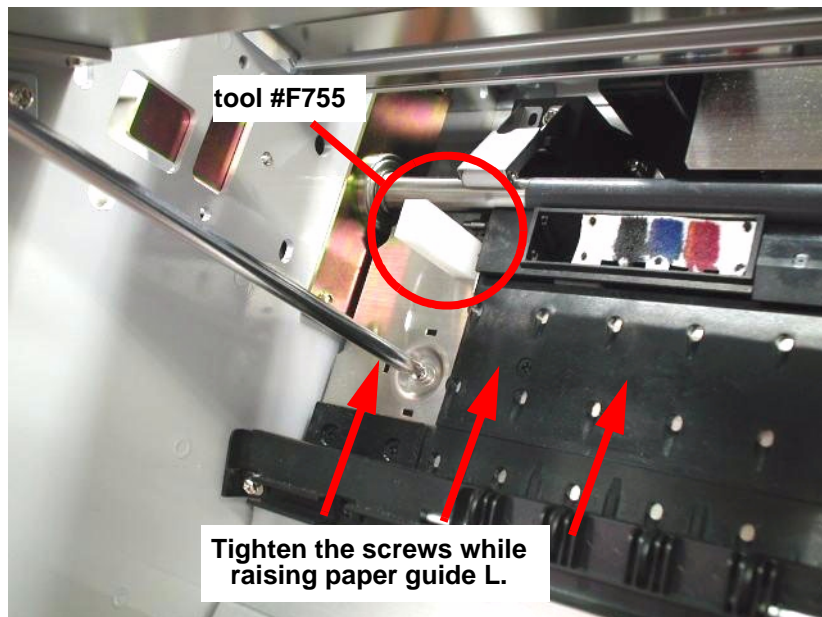

Figure 5-14. Paper Guide L Assembly Position Adjustment (1/2)

2. Set tool No. #F755 between paper guide L and the platen on the printer's right side as shown in the figure below. While pushing up the paper guide L toward the sub-platen (upward), tighten the 5 screws on the right side of the paper guide L to fasten it.

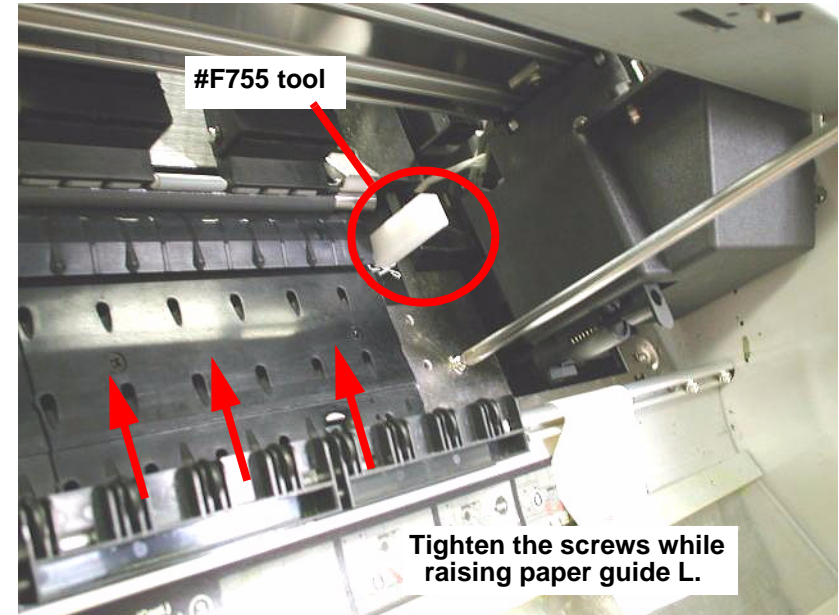

Figure 5-15. Paper Guide L Assembly Position Adjustment (2/2)

3. Set tool No. #F755 between the paper guide L and platen on the printer's left side again, then confirm that the tool cannot be inserted smoothly. If the tool can be inserted smoothly, adjust the paper guide L's assembly position on the left side again.



- The criterion of this adjustment is to adjust the paper guide L assembly position so that when tool, No. #F755, is inserted and pulled out from between the paper guide L and the platen, somewhat of a load is felt.
- After carrying out this adjustment, be sure to make the following adjustments.
 - Cutter Installation Position Adjustment
 - Paper Cutting Position Check
 - CR Cover Height Adjustment

CUTTER POSITION ADJUSTMENT

This adjustment is performed for the following purposes.

- To assemble the cutter assembly so that it is parallel to the cutter groove position on the sub-platen on paper guide L.
- To assemble the cutter assembly in the correct position with respect to the cutter groove position on the sub-platen on paper guide L.

NOTE: The paper guide L installation position adjustment should be performed before this adjustment is performed.

1. Take out the 2 screws holding the CR Cover, then remove the CR cover.
2. Insert the projections on tool # 759 in the row of holes in the 2nd level of the sub-platen on the right side of the sub-platen, installing the tool.

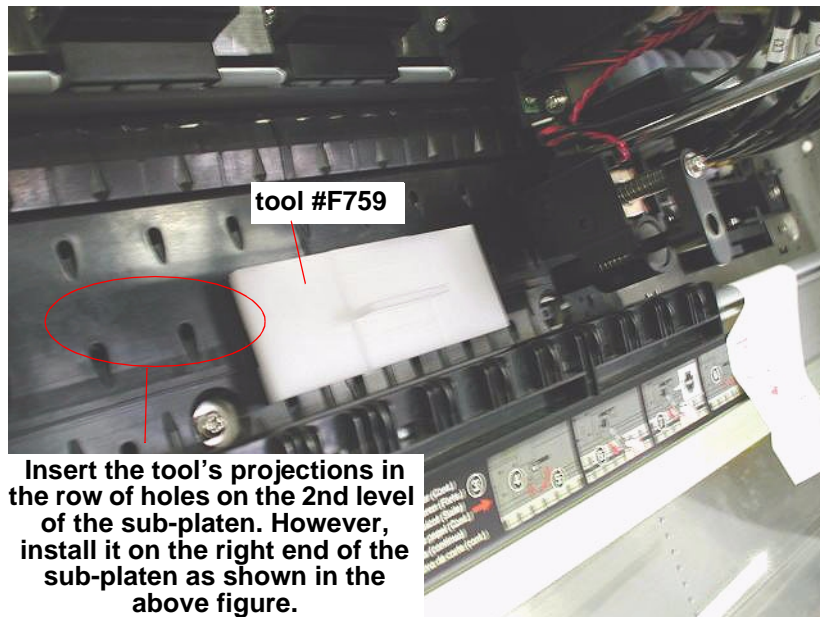

Figure 5-16. Setting tool #F759.



- The projections on tool No. #F759 should be inserted securely in the row of holes on the 2nd level of the sub-platen.
 - The three notches in tool No. #F759 should fit the ribs on the sub-platen.
3. Move the CR unit so as to cover tool No. #F759, set on the sub-platen. At this time, the rib on the tool should pass between the cutter assembly and solenoid.
 4. Loosen the 2 screws holding the cutter solenoid and cutter assembly, then push the cutter assembly to the rib on the tool.

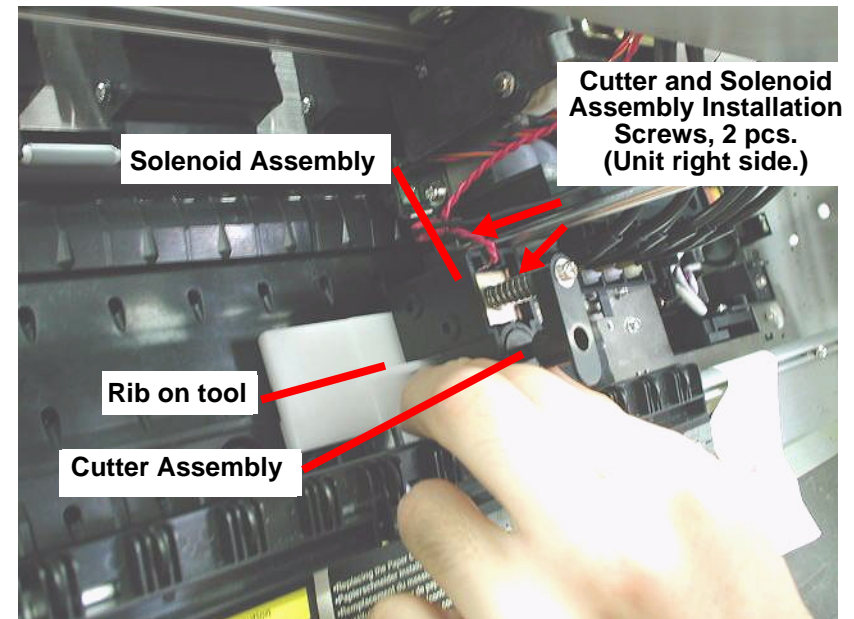

Figure 5-17. Cutter Position Adjustment

5. Tighten the 2 screws holding the cutter solenoid and cutter assembly.
6. Tighten the 2 screws holding the CR cover and assemble the CR cover.



- After performing this adjustment, be sure to perform the following adjustments.
 - Paper Cutting Position Check
 - CR Cover Height Adjustment

PAPER CUTTING POSITION CHECK

This check operation, by actually cutting paper, checks the following adjustment results of the adjustment which was carried out previously, which determine the paper cutting position.

- Paper Guide L Assembly Position Adjustment
- Cutter Positioning Adjustment

1. Set paper (minimum size: 10 cm wide x 20 cm) in the paper path along the paper setting position on the right side of the printer, then lower the paper set lever and set the paper.
2. Move the CR manually to the right edge of the paper, then lower the cutter manually.
3. While holding the bottom edge of the paper with one hand, cut the paper with the cutter.
4. Set a gauge with minimum measuring units of 0.5 mm at the edge of the cutter level difference on the sub-platen and check if the distance from the edge of the cutter level difference to the actual paper cutting position is within $0.5 \text{ mm} \pm 0.2 \text{ mm}$.
5. If the measuring results are outside the standard, loosen about 2 of the screws holding the paper guide L, then carry out fine adjustment of the paper guide L's assembly position.



- The length from the edge of the cutter level difference to the front edge of the paper where it was actually cut should be within $0.5 \text{ mm} \pm 0.2 \text{ mm}$.
- If you are adjusting the assembly position of the paper guide L, the installation screws that are loosened should be the absolute minimum number of screws necessary to adjust the position. If a large number of screws is loosened, the assembly position of the paper guide L will shift a great distance from the original adjustment position, so caution should be exercised.

6. In the same way, set paper on the left side of the printer, cut the paper manually and measure the length from the cutter level difference to the front edge of the paper. If the measurement results are not within the standard, loosen about 2 of the screws holding the paper guide L and carry out fine adjustment of the paper guide L's assembly position.

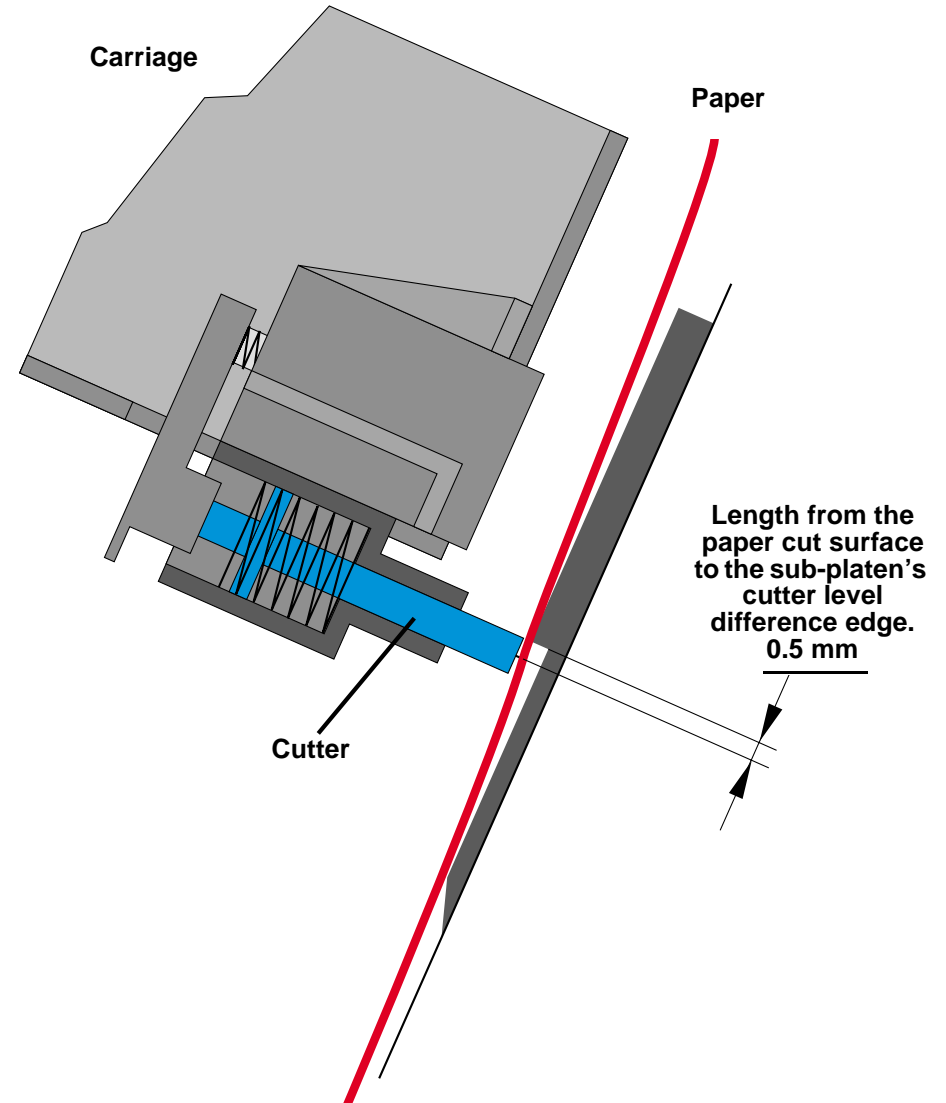



- After performing this adjustment, be sure to perform the following adjustment.
 - CR Cover Height Adjustment

CR COVER HEIGHT ADJUSTMENT

This adjustment is applicable in the case of all operations which are accompanied by removal and installation of the CR cover.

The CR cover restricts the cutter solenoid's actuator operating position, and this adjustment sets the CR cover so that the cutter operates at the proper stroke when it is being used to cut paper.

1. Set the "CR Cover Position Adjustment tool No. #F724, on the sub-platen in the position shown in the following figure along the sub-platen on paper guide L.
2. Move the carriage over the tool while matching it to the level difference in the tool, and check if the cutter blade enters the groove.



The cutter blade is made from an ultra-hard material and should not be bumped against any metal parts. (Bumping it could cause it to become nicked.)

For this reason, if you are moving the cutter blade in the tool, move it while pushing the cutter front end up with your finger.

3. Fasten the CR cover with it pushed down so the cutter pushes against the tool. (Since the position will change only as much as the amount of looseness in the installation screw holes, position it so that it will hit against the tool.)

Standard: 9.75 +/- 0.25 mm (Using tool: #F724)

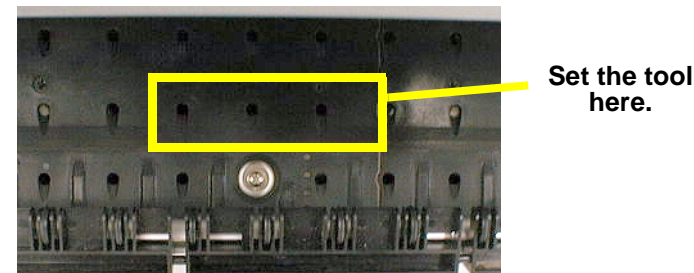
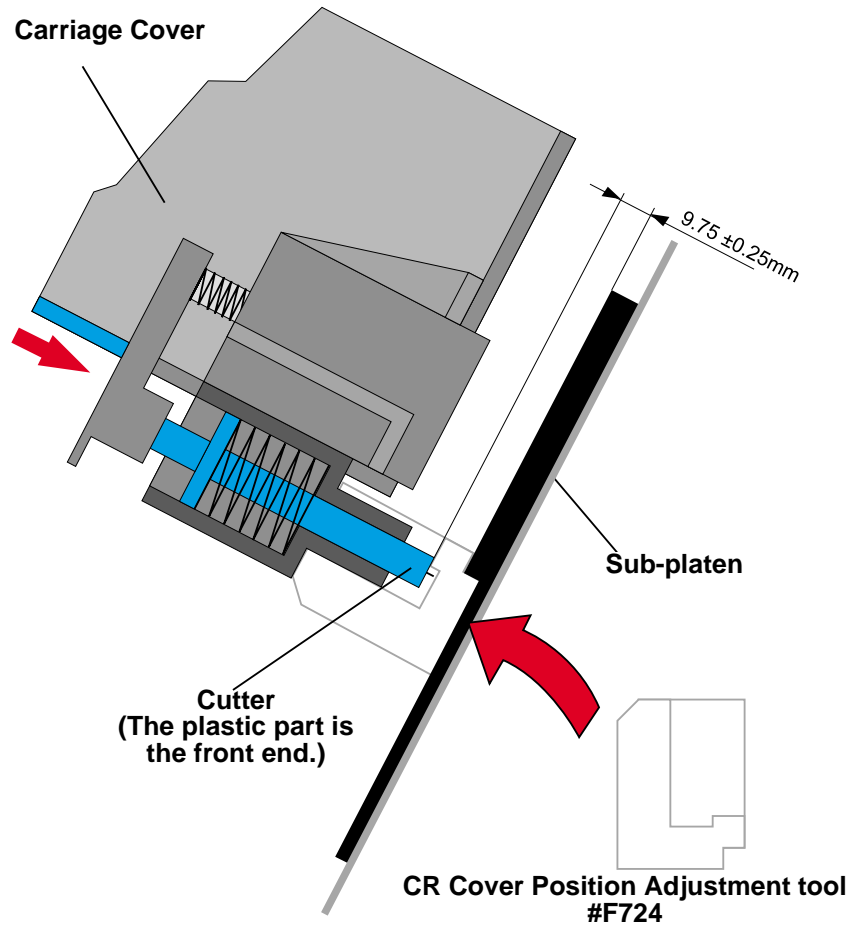

Figure 5-18. Checking the tool Setting Position



CR ENCODER SENSOR INSTALLATION POSITION ADJUSTMENT

This adjustment is performed to install the CR encoder sensor in the appropriate position with respect to the CR linear scale.



- The CR encoder sensor used in the Stylus Pro 9500 differs in its shape from the CR encoder sensor used in the Stylus Pro 9000, when using tool #766 in this adjustment, it should be used only after confirming the shape of the CR encoder sensor.

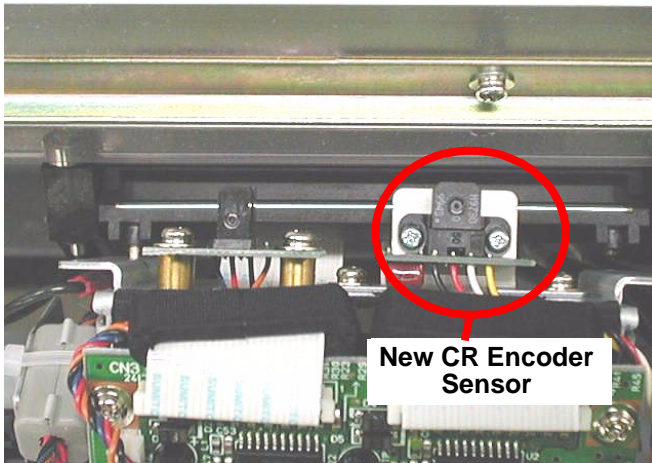

Figure 5-19. CR Encoder Sensor Shape

1. Loosen the 2 CR encoder sensor installation screws and set tool #F766 between the CR encoder sensor and CR guide rail as shown in the figure below.
2. Push the CR encoder sensor toward the tool lightly, then tighten the 2 CR encoder installation screws.

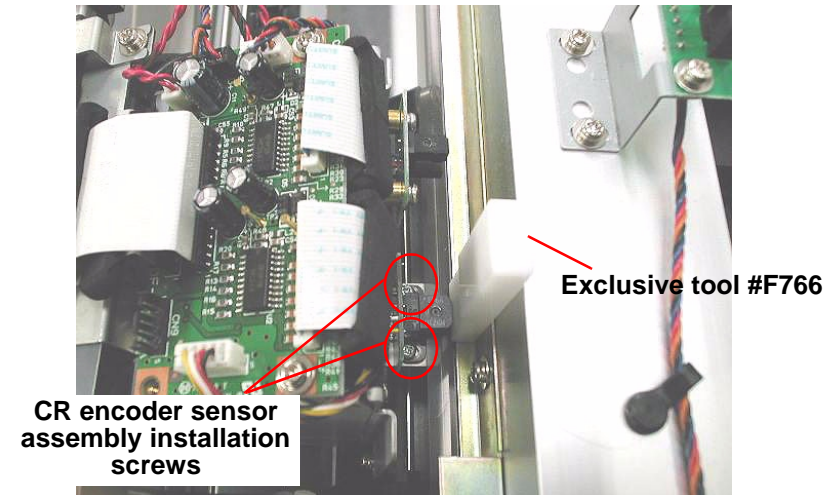

Figure 5-20. CR Encoder Sensor Installation Position Adjustment

PF ENCODER SENSOR INSTALLATION POSITION ADJUSTMENT

This adjustment is performed to set the distance between the PF roller shaft (grid roller) and PF encoder sensor in the proper position. Through this adjustment, the position of the PF encoder sensor's emitter and receptor are set properly with respect to the slits in the loop scale for the PF motor.

1. Loosen the 2 PF encoder sensor installation screws, then set the tool, #F764 on the round hole side of the PF roller shaft, fitting the notched end against the PF encoder sensor's emitter (outside).
2. Move the PF encoder sensor up and down so that it is in a position where the clearance between the outside part of the PF encoder sensor and the notch in the tool, #F764 becomes uniform, then tighten the 2 PF encoder sensor installation screws.

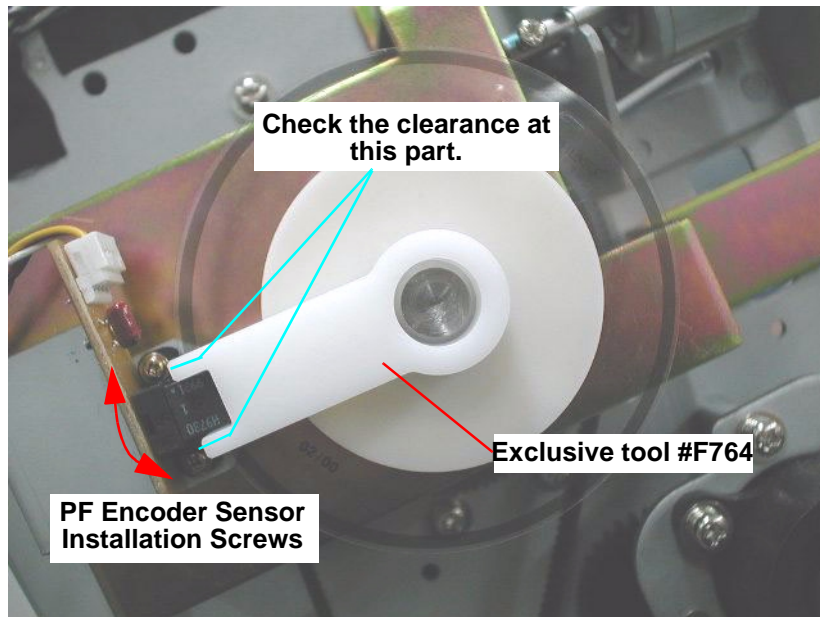

Figure 5-21. PF Encoder Sensor Installation Position Adjustment

PF ENCODER SENSOR INSTALLATION POSITION ADJUSTMENT 2

This adjustment shifts and adjusts the PF encoder sensor on each installation frame so that the loop scale on the PF roller shaft is positioned virtually in the center between the PF encoder sensor's receptor and emitter. Through this adjustment, it becomes possible to read the slits on the loop scale more accurately.

1. Loosen the 2 PF encoder assembly installation frame installation screws, then set the tool #F765 in the PF encoder sensor's emitter side (outside) position.

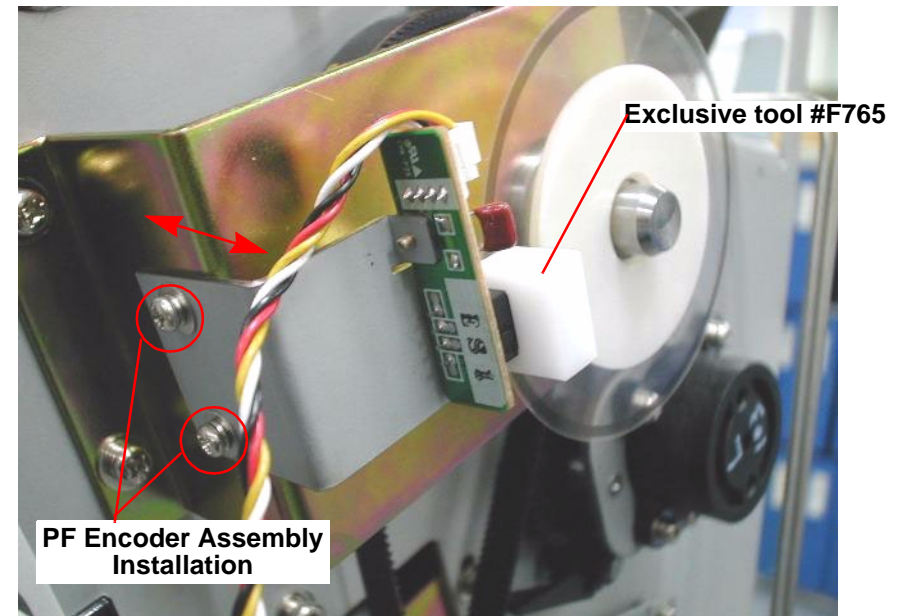

Figure 5-22. PF Encoder Sensor Installation Position Adjustment 2

2. Turn the PF roller one time by hand (use the reduction belt), then check if loop scale is touching the front end of the tool, #F765. If it is found to be touching, shift the PF encoder sensor installation frame gradually toward the printer's outside to a position where the loop scale does not touch it in even a full rotation, then tighten the 2 installation screws.

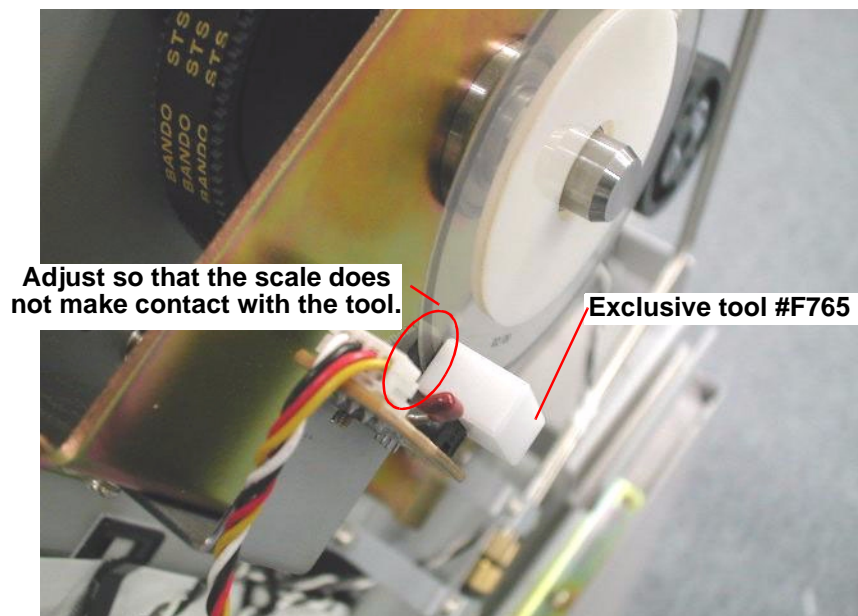

Figure 5-23. Check Points



Due to sensor characteristics, the reading accuracy of the sensor has a tendency to drop if the scale makes contact with the sensor's emitter side (outside).

CR STEEL BELT TENSION ADJUSTMENT

This adjustment is necessary for service operations that require you to remove/loosen the CR Motor or CR Steel Belt. When replacing or re-installing the CR Steel Belt, you need to confirm the tension of the CR Steel Belt. Tighten or loosen the screws on the Driven Pulley to increase or decrease the tension.

Standard: 100g ± 10% (at the point where the CR Steel Belt contacts the CR Rail)

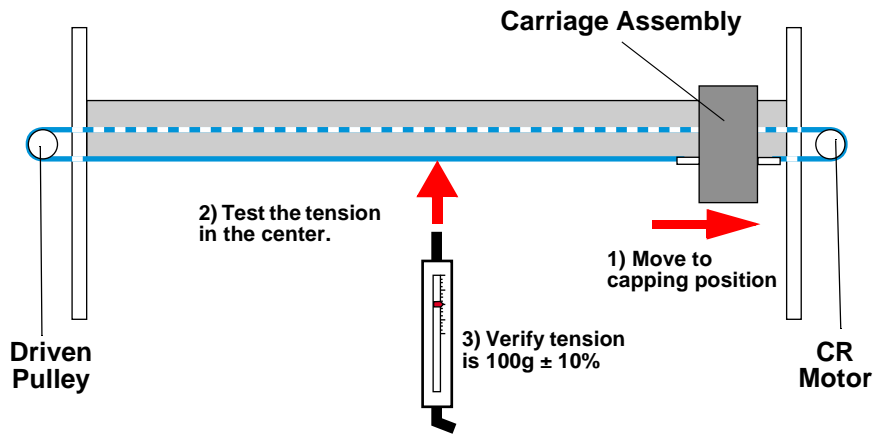

Figure 5-24. CR Steel Belt Tension

PF BELT TENSION ADJUSTMENT

This adjustment is necessary for service operations that require you to remove/loosen the PF Motor or PF Belt. When replacing or re-installing the PF Belt, you need to confirm the tension of the PF Belt.

Standard: 3500g ± 10%

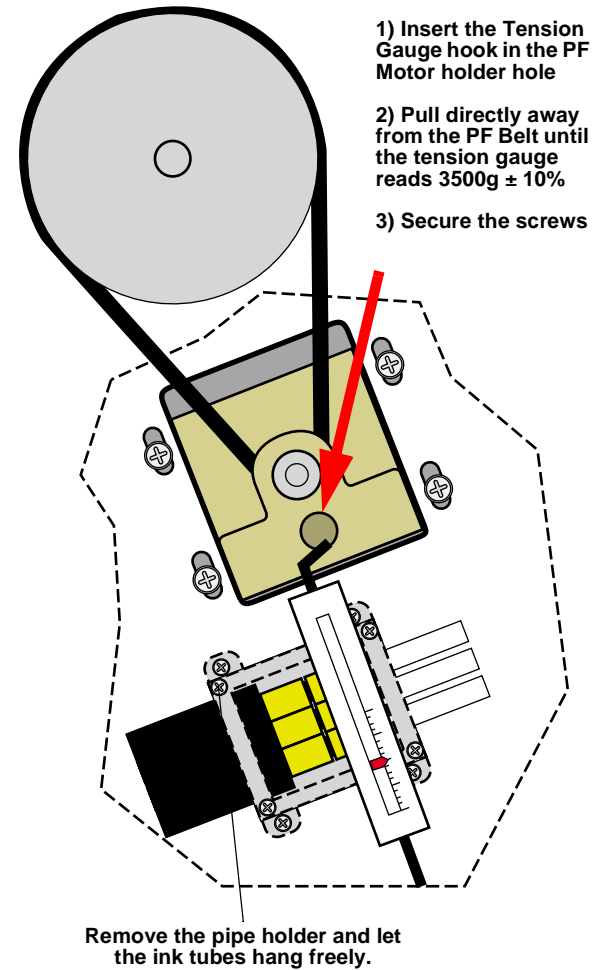

Figure 5-25. PF Belt Tension

GEAR BACKLASH ADJUSTMENT

This adjustment is performed in the case that the SLID motor assembly has been removed and installed. It sets the amount of backlash between the slide idler gear, mounted on this assembly, and the slide gear, mounted on the carriage, so that it is appropriate, and so that both gears mesh smoothly during a head height change after HP seek.

Adjustment: Loosen the screw shown in the figure below, then move the motor assembly while checking the amount of backlash and fasten it at the appropriate position.

Standard: At the level where the slide idler gear slides smoothly in the axial direction.

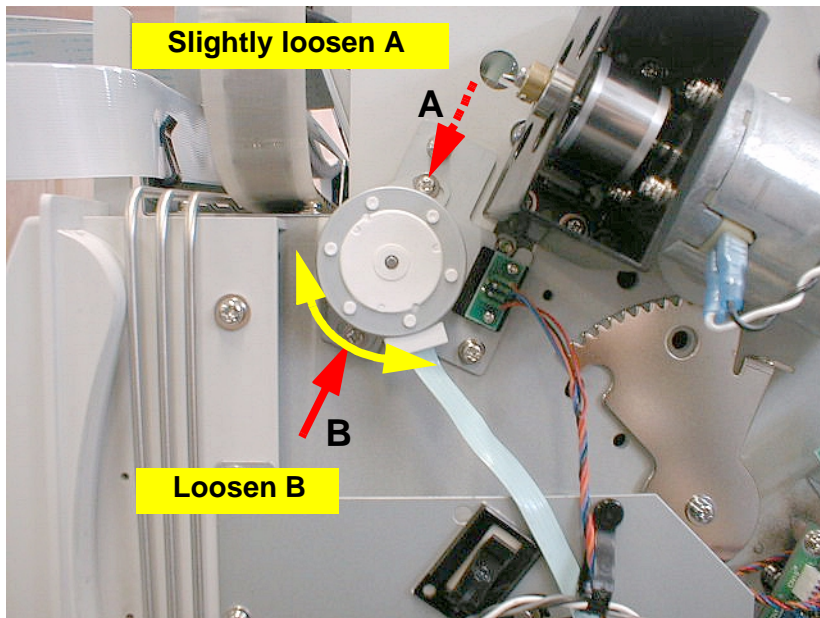

Figure 5-26. PG Motor - Backlash Adjustment

I/H LEVER POSITION ADJUSTMENT

This adjustment is necessary for service operations that require you to remove the I/H subassembly which is located inside the Ink Cartridge Holder. The I/H Lever controls the I/H subassembly position (up or down), and when the I/H lever is properly installed, the I/H subassembly moves up and down smoothly.

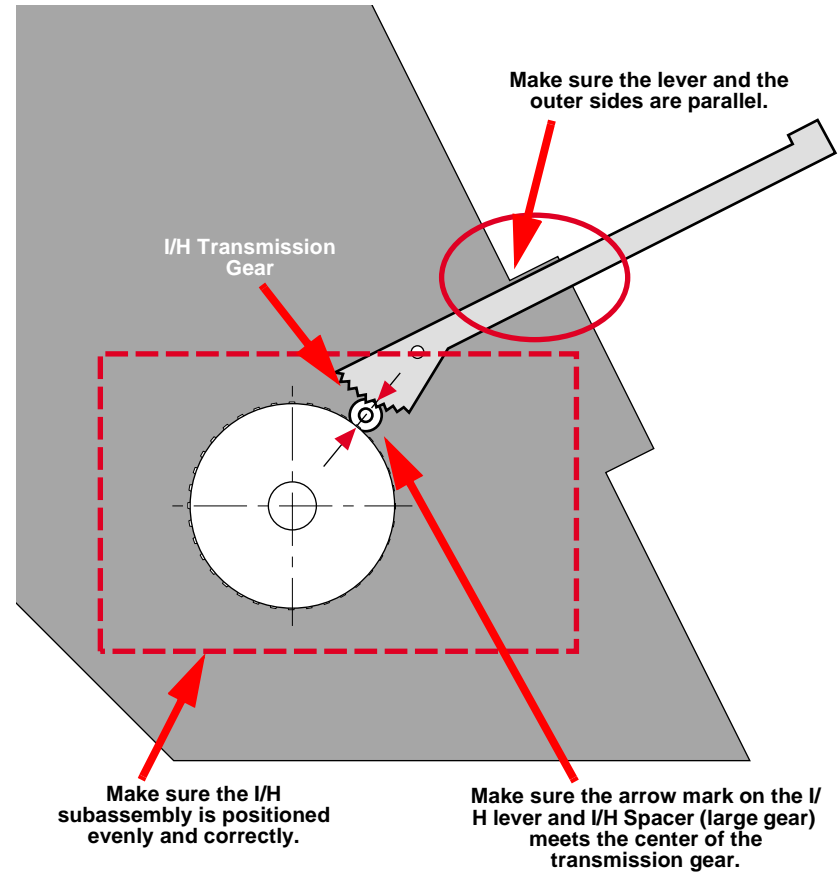

Figure 5-27. I/H Lever Position

P THICK SENSOR ASSEMBLY ADJUSTMENT

When removing/replacing the P THICK sensor, verify the sensor operation using the Self-Diagnostic mode as described below.

1. Press the following buttons and turn on the printer to enter the Self-Diagnostics mode.

[Paper Feed ↓] + [Cut/Eject] + [Cleaning]

2. Press the SelecType or Item button until "Check: Test" appears in the LCD, then press the Enter button to select the Test menu.
3. Press the SelecType or Item button until "Test: Sensor" appears in the LCD, then press the Enter button to select the Test Item menu.
4. Press the SelecType or Item button until "Sen: Paper xxxx" appears.
5. Raise the Release lever to the "Release" position, and verify that "Sen: Paper Thick" appears in the LCD.
6. Insert a schema gauge (0.6mm/0.7mm) between the PF Grid Rollers and Driven Rollers nearest the HP. Lower the Release lever to the "Lock" position. The LCD message will vary according to the schema gauge as shown in the table below.

Table 5-20. P THICK Sensor Operation Check

Schema Gauge	LCD Message
0.7mm (thick paper)	Sen: Paper Wide
0.6mm (standard paper)	Sen: Paper Std

7. If the correct message does not appear or any other message appears, verify the P THICK sensor is installed correctly and check the operation again.

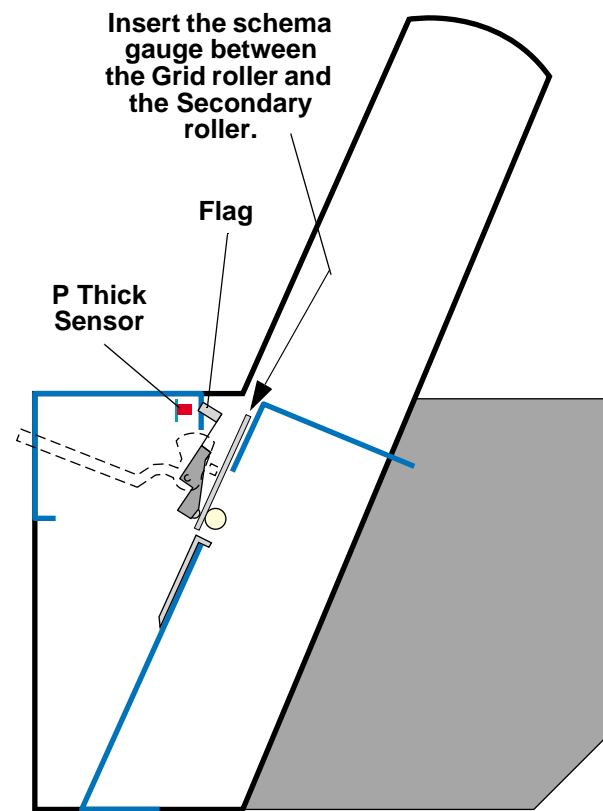

Figure 5-28. P Thick Sensor Adjustment

COVER, R/L SENSOR ASSEMBLY ADJUSTMENT

When the cover R/L sensor assembly is removed and installed, or the front cover assembly is removed and installed, the cover R/L sensor assembly's installation position should be adjusted before the H-Top cover and R/L side

cover are installed. Through this adjustment, the cover R/L sensor assembly is installed in the proper position and the interlock function is caused to operate normally when the cover is opened and closed.

1. With the H-Top cover and the R/L side cover in the uninstalled condition, set tool #F754 on the right edge of the front cover as shown in the figure below, then close the front cover until tool #F754 makes contact with the CR frame.

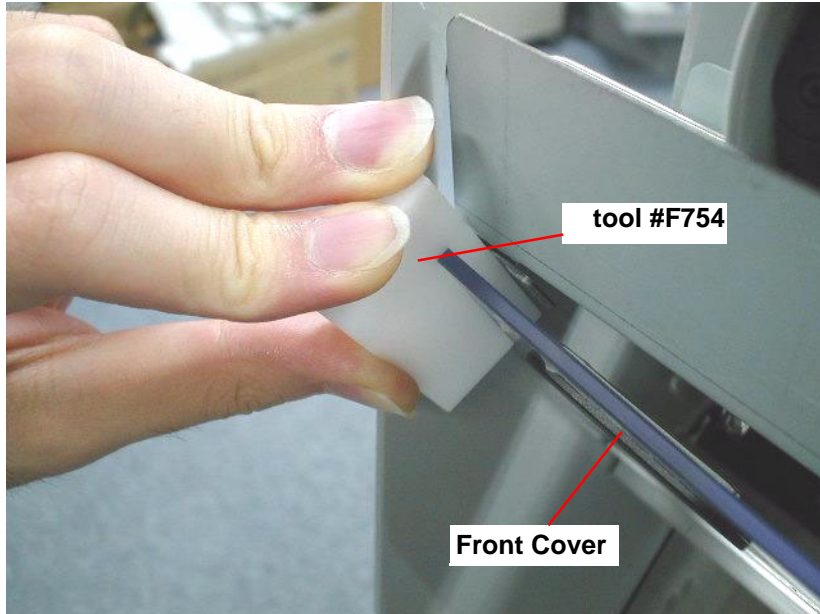
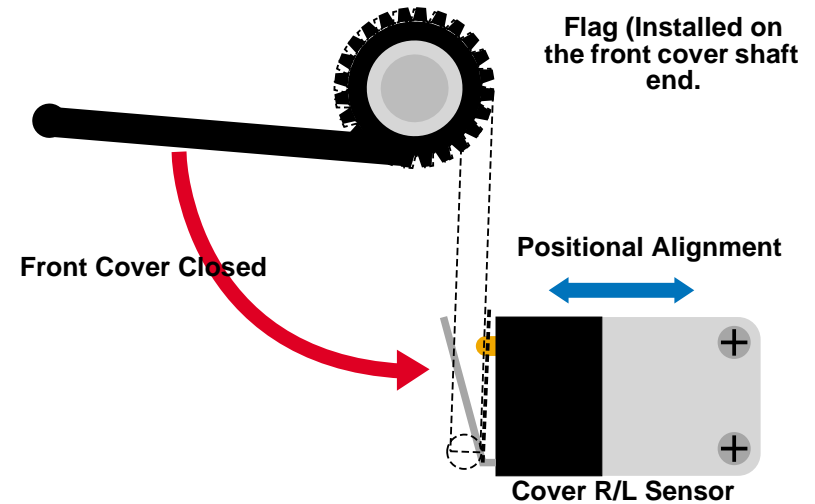

Figure 5-29. tool #F754 Installation Position

2. Check the state of the cover R/L sensor assembly with the printer in the above state. There is no problem as long as the sensor goes On in a state where the proper amount of clearance is provided, but in the case of the following states, loosen the 2 screws used to install the cover R/L sensor assembly, then adjust the sensor's position forward and backward, and tighten the installation screws.
 - The cover R/L sensor assembly's switch lever is pressed by the front cover flag to such an extent that it bends.

- The cover R/L sensor assembly switch is not turned ON by the front cover flag.



CAUTION If both the left and right sensors do not operate correctly, even if the front cover is closed, the “Cover is Open” error will be displayed, so the position and operating state of the left and right sensors should be checked.

3. Set tool #754 on the left edge of the front cover, then close the front cover until tool #F754 makes contact with the CR frame, then check and adjust in the same way as in Step 2) above.

It is also possible to check the sensor's moving state with the following Self-diagnostic function.

NOTE: In any case, the following operation is only a check operation, so if the cover R/L sensor assembly is replaced or the front cover is installed, the adjustment shown on the previous page should be carried out when assembly is done. The following operation is effective only when the H-Top cover and R/L side cover are assembled.

1. Press the following buttons and turn on the printer to enter the Self-Diagnostics mode.
Paper Feed ↓ + Cut/Eject + Cleaning
2. Press the SelecType or Item button until "Check: Test" appears in the LCD, then press the Enter button to select the Test menu.
3. Press the SelecType or Item button until "Test: Sensor" appears in the LCD, then press the Enter button to select the Test Item menu.
4. Press the SelecType or Item button until "Sen: Cover xxxx" appears.
5. Open and close the Front Cover, checking the LCD to make sure the message changes depending on the Front Cover position.

Table 5-21. Cover R/L Sensor Assembly Check

Front Cover	LCD Message
Open	Sen: Cover Open
Closed	Sen: Cover Close

6. If the correct message does not appear or any other message appears, verify the Cover R/L Sensors are installed correctly and check the operation again.

5.2.10 Dip SW setting

The ASP on the C277MAIN board is common with that in the Stylus Pro 9000, but due to the mechanical configuration, the DIP-Switch settings on the MAIN board differ as shown below.

Table 5-22. C277MAIN Board DIP-SW Settings

DIP SW1	DIP SW2	Affected Product	Mechanical Configuration	
1	OFF	ON	Stylus Pro 9000	<ul style="list-style-type: none"> • PF Roller: 3 roller configuration • PF Motor: Built-in encoder
2	ON	OFF	No affected product	<ul style="list-style-type: none"> • PF Roller: 1 roller configuration • PF Motor: Built-in encoder
3	OFF	ON	Stylus Pro 9500	<ul style="list-style-type: none"> • PF Roller: 1 roller configuration • PF Motor: Encoder is mounted externally.
4	ON	ON	No affected product	Spare Setting

The DIP switch factory setting for the ASP C277MAIN board is setting No. 1 above, so if it is used in the Stylus Pro 9500, the setting should be changed to No. 3 in the table above. The location of the DIP Switch is as shown in the following figure.

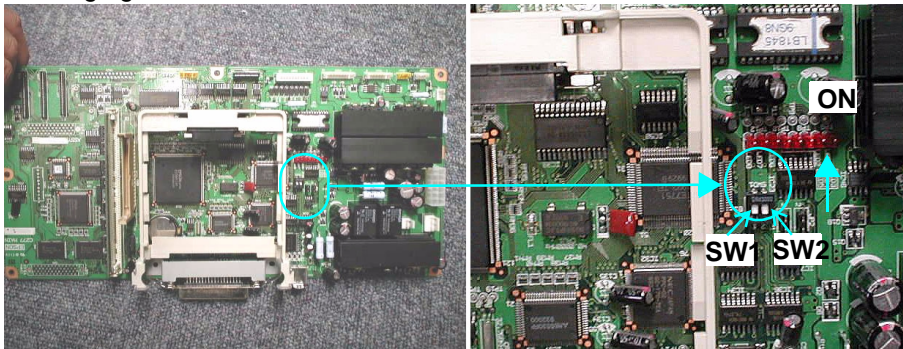

Figure 5-30. C277MAIN DIP Switch Settings

NOTE: Jumpers J1 and J2 should be used with the short setting as is. If the setting is changed, the printer will cease to operate.

CHAPTER

6

MAINTENANCE & SETUP

6.1 General Maintenance Issues

This section explains necessary maintenance items and their details for this product. Basically for this product, service technicians are required to visit the user's location where the EPSON Stylus Pro 9500 is used, and perform necessary maintenance service on-site while following the precautions below. Service technicians have to be extra careful not to cause any accident to the product or the user's environment.



- Since the power switch mounted on the secondary circuit of the power supply circuit, unless otherwise specified, always disconnect the power cable from the AC plug socket in order to prevent electric shock during service operations.
- The cover open sensor for detecting the open/close condition of the front cover has an interlock switch that functions as a safety device. Therefore, it is prohibited to turn off this switch.
- A lithium battery is used to back up memory and is mounted on the control circuit board. To prevent accidents, follow the precautions below when handling the board.
 - *Do not short the battery.
 - *Do not set the battery on the wrong poles, double check the plus and minus sides when installing the battery.
 - *Do not heat up or place the battery neat a heat source.
- Be careful not to let ink get into your eyes or your skin. If ink gets in your eye, flush the eye with water, and see a doctor if you feel discomfort in your eye.



- Due to the printer's size, when performing any service or maintenance operations, confirm there is plenty of space for the operation.
- Due to the printer's size and weight, make sure the area you move and place the printer is stable.
- Since the EPSON Stylus Pro 9500 is very heavy (approximately 96 Kg for the printer body + stand), be careful when handling it. When separating or assembling the printer body and legs, it is recommended to do so with at least 4 people.
- When removing parts, ink may drip on the floor or lower sections of the printer. Therefore, spread a sheet or similar object when removing ink-related parts.
- When handling the electric circuit boards, do not touch the elements on the board by the bare hands in order to prevent the elements from getting damage by static electricity. If necessary, wear the earth band.
- If it is necessary to power on the printer after removing various covers by necessity, be careful not to get injured from the carriage or fan.
- Since the steel belt for driving the carriage and cutter blade are very sharp, be careful not to cut yourself.
- Since the cutter blade is made of very hard material but weak against shocks, do not let it collide with the printer's metal parts.
- If the installed printer needs to be packed and transported for any reasons, use the all the exclusive packing materials and protection materials written on the "Start-Up Guide" and "Assembly and Setup Guide".

6.1.1 Periodic Maintenance Items

The printer uses sensors and counters to determine when consumable items need to be replaced. When a consumable part has reached its predetermined end-of-life according to the corresponding counter, a message appears. See the table below for parts which require periodic replacement.

Table 6-1. Parts That Require Periodic Replacement

Items	LCD Message	Description
Waste Ink Pads (R/L)	“Maintenance Call 0100” or “Service Call 00000100”	<input type="checkbox"/> Solution Replace the following parts; <ul style="list-style-type: none"> • Waste Ink Pads (R/L) • Pump Assembly • Cap Assembly • F Box (R/L) • Cleaner, Head <input type="checkbox"/> Required Adjustments <ul style="list-style-type: none"> • Cleaner Counter (See “Maintenance Mode” on page 37.) • Cutter Position Adjustment (See “CR Encoder Sensor Installation Position Adjustment” on page 210.)
Ink Tubes	“Service Call 00000101”	Solution <ul style="list-style-type: none"> <input type="checkbox"/> Check the ink tube (The printer indicates this error when the useful-life ends for the specified part.) If use is continued for a long time, initialize the CR motor’s life counter. See page 34.



When replacing the waste ink pads, replace the pads in the waste ink tank and not the whole tank. Put the old pads in a plastic bag and throw away the used ink pads correctly, according to the laws and rules in your area.

6.1.2 Product Life Information

The table below shows the product life about the printer body, each mechanism and various parts. Information regarding to the product life can be checked by the following way.

- Panel Setting: "Printer Status Menu"
The amount of ink remaining is indicated on the LCD. ("F****E" - F = full, E = empty, and each asterisk * represents a percentage of the total ink.) Also, the counters which record these values can be initialized by "Maintenance Mode 2".



Do not perform the counter initialization without replacing the corresponding parts and checking their operation. Since the counters for "Waste Ink Life" and "Ink Remaining Quantity" influence printer operations, do not clear them unnecessarily.

- Self-Diagnostic Function: "Check: Maintenance" under "Test" menu

Table 6-2. Product Life Information

Items	Setting value	Notes	Result = Error
Printer	18,000 pages	B1 paper	No
Printheads	2 billion dots	Each nozzle	No
Waste Ink Pads	Right: 132,000 points Left: 6,600 points	1 point = 0.02ml	Yes
CR Motor	2,500,000 passes	1 pass = 1 round trip *Ink tube life is monitored based on this counter value.	Yes
PF Motor	23,000 meters	Paper feed distance	No
Cutter	2,000 operations	1 operation = cut one page	No

6.1.3 Important Maintenance Items During Service Operations

Check the following items during printer maintenance/service and perform any necessary operations.

Table 6-3. Items to be Checked During Maintenance/Service

Items	Check Points	Remedy
Lower Paper Guide and the surface of the Subplaten	Make sure no paper, dust, or foreign objects are attached or have accumulated.	Cleaning (If there is an ink stain, wipe with dry, clean cloth after cleaning the ink stain with damp cloth.)
Step Ruler (Striped plastic sheet used by Linear Encoder to determine CR position)	Make sure no dust or foreign objects are attached or have accumulated, and make sure it is not ripped, bent, or stained.	After attempting to clean, if there are any rips or stains, replace with new one.
Rail on the CR guide frame	Make sure there are no foreign objects attached.	Cleaning
P_REAR sensor and P_FRONT sensor surface	Make sure no paper, dust, or foreign objects are attached or have accumulated.	Cleaning
PF Encoder Sensor and Loop Scale	Is there any paper dust or foreign matter accumulating or adhering?	Cleaning If there is any damage, replace it.

6.1.4 Lubrication

In this product, there are no required lubrication parts.



Therefore, never lubricate the printer mechanism since the lubrication may damage the mechanical parts and shorten the product life.

6.2 Unpacking and Installing

Since the EPSON Stylus Pro 9500 is extremely large (W x H x D: 1688 x 1259 x 699mm) and very heavy (96Kg/ printer body + legs), carefully follow the procedures explained here from unpacking and assembly to setup and installation. Read and follow all safety instructions carefully for the safety of the installers and the equipment. Also, if the printer needs to be repacked and transported again after it is installed, perform necessary packing procedures after checking the service operations and packing conditions written here.

6.2.1 The Packaging

The printer comes from the factory packed in a large box (printer body and accessories), and is delivered with a smaller box on top (for the stand and lower accessories).

BEFORE OPENING THE LARGE & MEDIUM BOXES

See the figure below for the packing condition and contents.

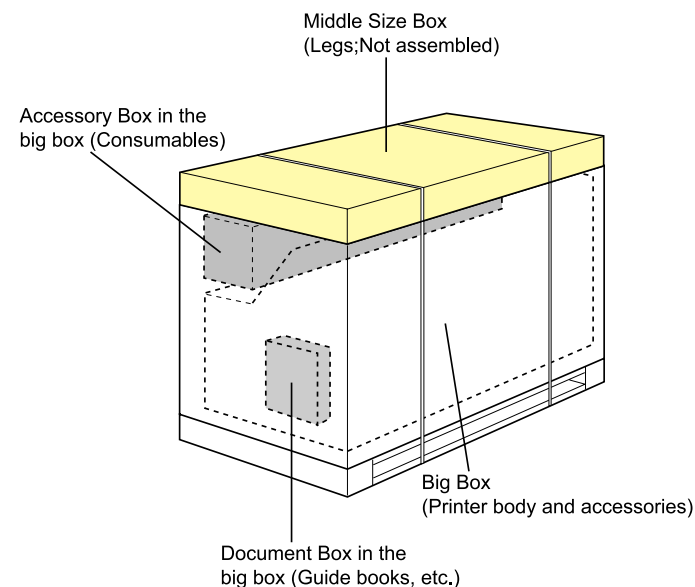

Figure 6-1. The printer and parts shipped in boxes

6.2.2 Contents of the Packaging

See the following for the contents of the large and medium size boxes.

MEDIUM-SIZE BOX

Parts packed in the medium-size box are as follows.

- Legs x 2 (one for left and right)
- Leg connections x 2 (for connecting the right and left legs / one each for top and bottom)
- Paper Eject Tray (Cloth/ metal shafts are attached inside)
- Tray Hooks x 2 (one each for right and left)
- Pins x 2
- Hexagon (Allen) wrench x 2 (large: 5mm / small: 4mm)
- Bolts (4 kinds)
 - For assembling the stand
 - * 8 bolts with hexagon hole (M6 x 30)
 - * 6 bolts with hexagon hole (M6 x 10)
 - For connecting the printer body and stand
 - * 2 washer bolts with hexagon hole (M6 x 12)
 - * 2 flange bolts with hexagon hole (M6 x 12)

LARGE BOX

The following parts are in the large box.

- EPSON Stylus Pro 9500 printer body
- 2 Spindles for roll paper (for 2-inch diameter roll paper)
- Accessory Box
 - * Ink Cartridges x 6 (one for each color)
 - * Roll paper
- Documentation Box (Guide Books and CD-ROM, etc.)

6.2.3 Unpacking and Assembling

FROM UNPACKING TO ASSEMBLING THE STAND

CAUTION



- It is recommended at least two people (four for printer body) unpack and assemble the stand. (Weight of stand: approximately 22kg after assembling.)
- Perform unpacking and assembly in a stable, open place (about 4 x 4m).

1. Remove the band connecting the large box and medium size box, and take out the medium size box.
2. Open the medium size box and verify the contents. (See the previous page.)
3. Install the top and bottom horizontal stand supports (holes facing correct direction) to the right-side leg and temporarily secure the top support with the hexagonal bolts (M6 x 10). Repeat for the left-side leg

CHECK POINT



Make sure the four holes on the upper support are on the left when facing the rear and on the right when facing the front.

4. Turn over the stand so that the bottom faces up. Then, connect the bottom support and secure the support with the hexagonal bolts (M6 x 30).
5. Turn over the assembled stand again, and completely secure the top-support bolts.

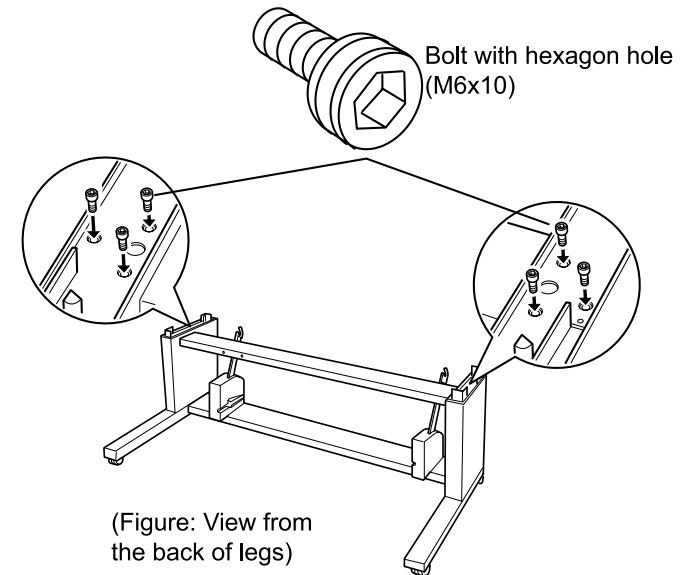

Figure 6-2. Stand Assembly 1

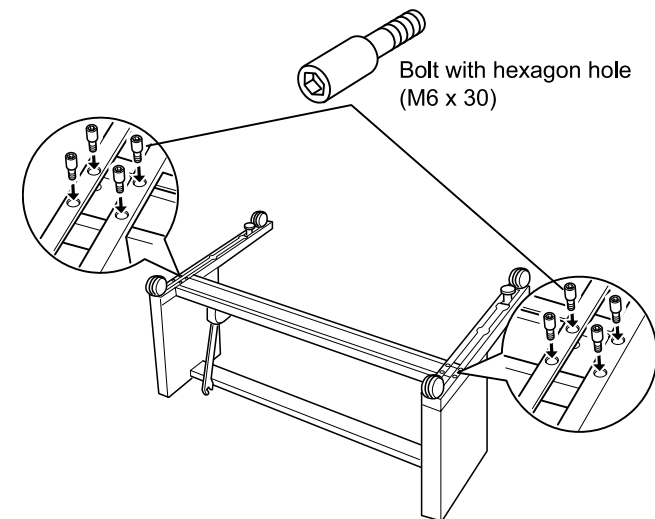
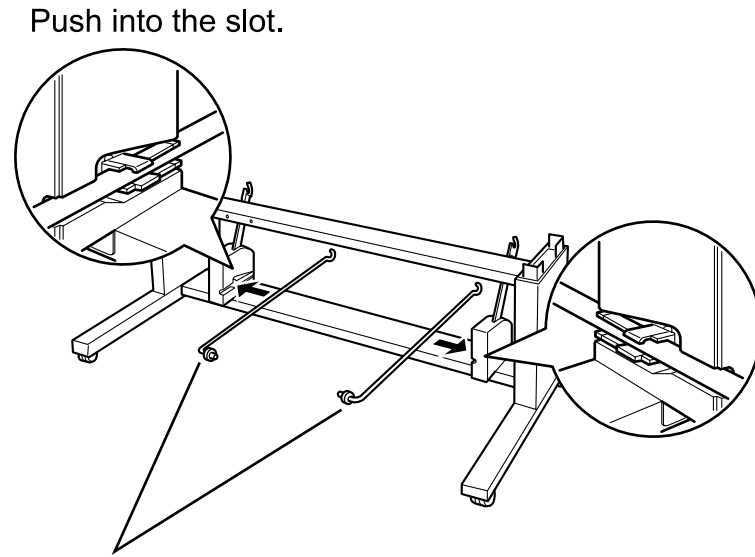

Figure 6-3. Stand Assembly 2

6. Insert the two tray hooks into the slots on the inner sides of the stand.



When installing the tray hooks, the sides with the plastic (resin) caps should be toward the rear of the printer and should face inward. (See the figure below.)



Tray Hooks
(Resin part should locate the rear of the legs and face inside)

Figure 6-4. Stand Assembly 3

7. Insert the eject tray pins into the holes located toward the rear of the right and left legs.

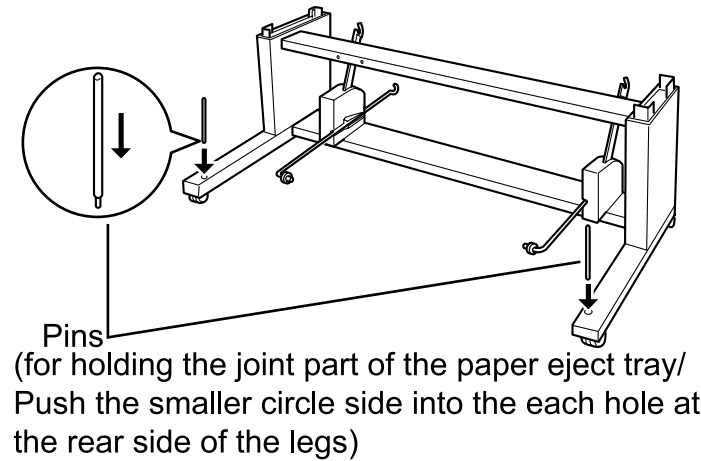

Pins
(for holding the joint part of the paper eject tray/
Push the smaller circle side into the each hole at the rear side of the legs)

Figure 6-5. Stand Assembly

8. Holding the eject tray cloth, locate the shaft which has a joint at both ends and connect those joint ends to the pins you set up in step 7. Connect the joints to the top of the pins and push down securely.

CAUTION

When installing the “Paper Eject Tray” cloth, make sure the seam (folded-fabric side) faces the floor (rear as shown below); otherwise, the printed-paper edge may get stuck on the seam.

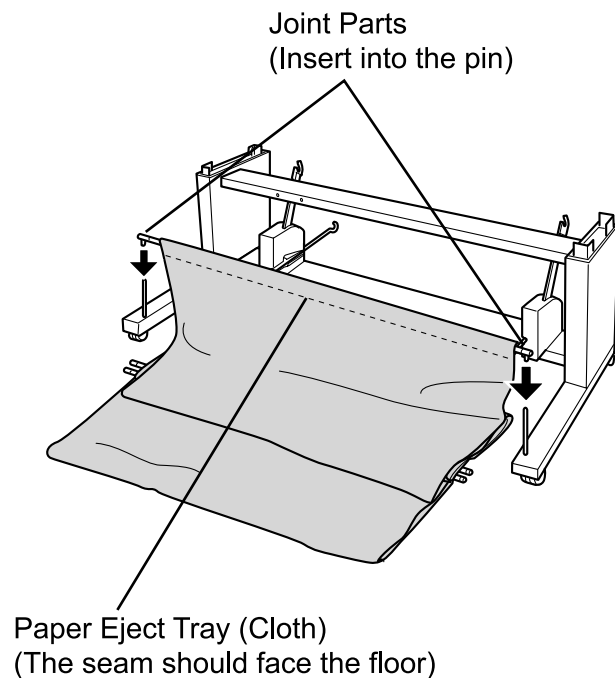

Figure 6-6. Stand Assembly 5

9. Move the other three Paper Eject Tray shafts, which are all in the cloth, in front of the stand and hang them on the hooks located at the tips of the right and left “Tray Arms”.

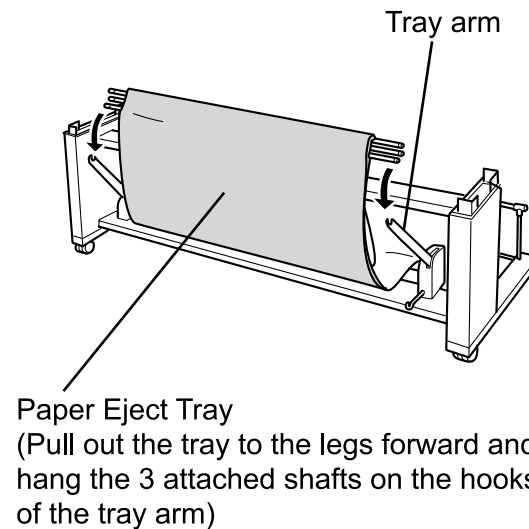

Figure 6-7. Stand Assembly 6

ASSEMBLING THE PRINTER BODY



- When lifting or moving the printer body, make sure to do so with at least 4 people. (The printer weighs approximately 74kg.)
- When removing the large box, be sure that there is enough space overhead. (2 meters of clearance is required.)

1. Open the large box by cutting the center of the sealed tape and take out the Accessory Box, two spindles and two styrol pads protecting the printer body on the right and left.
2. Take out the four box panels, one on each side of the box and remove the Documentation box.

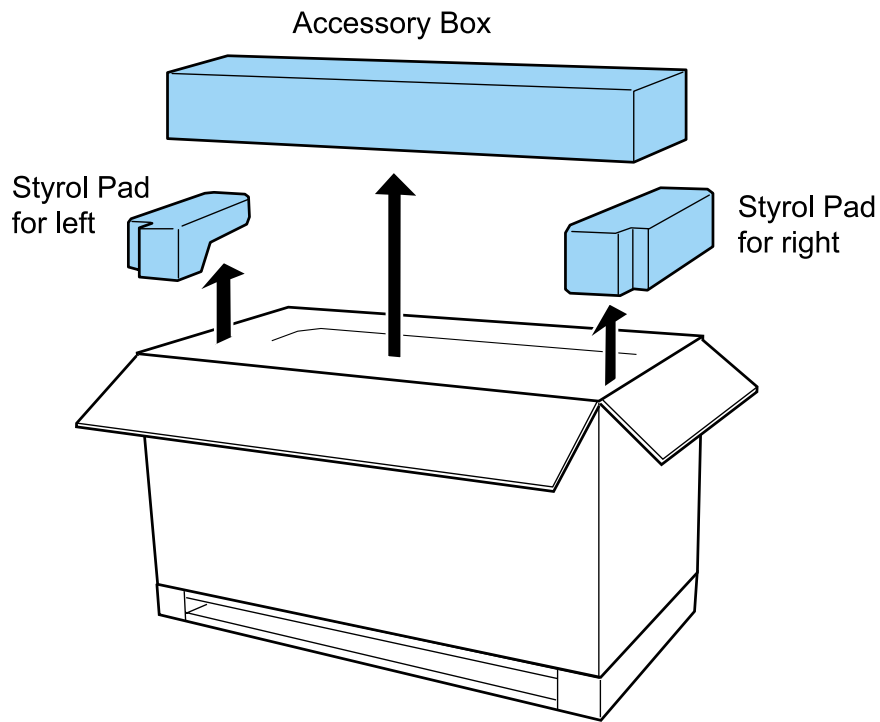

Figure 6-8. Body Assembly 1

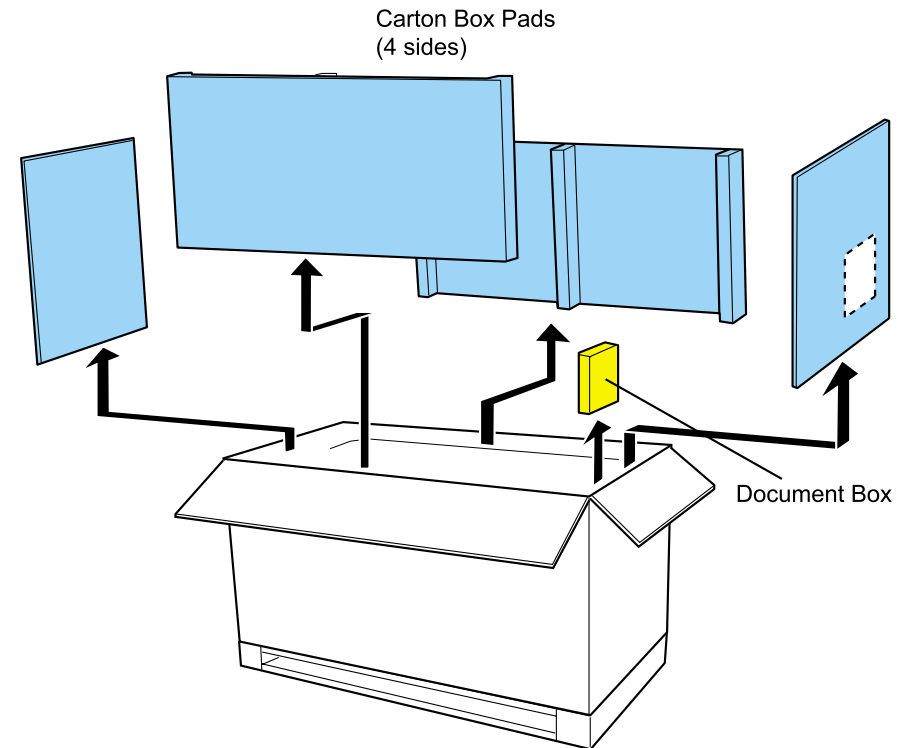

Figure 6-9. Body Assembly

3. Pull up the large box and store it.
4. As shown in the figure below, place the assembled stand in front of the printer body and lock the (front) right and left casters. Then lower the right and left leveling screws until you are sure they are secure against the floor.

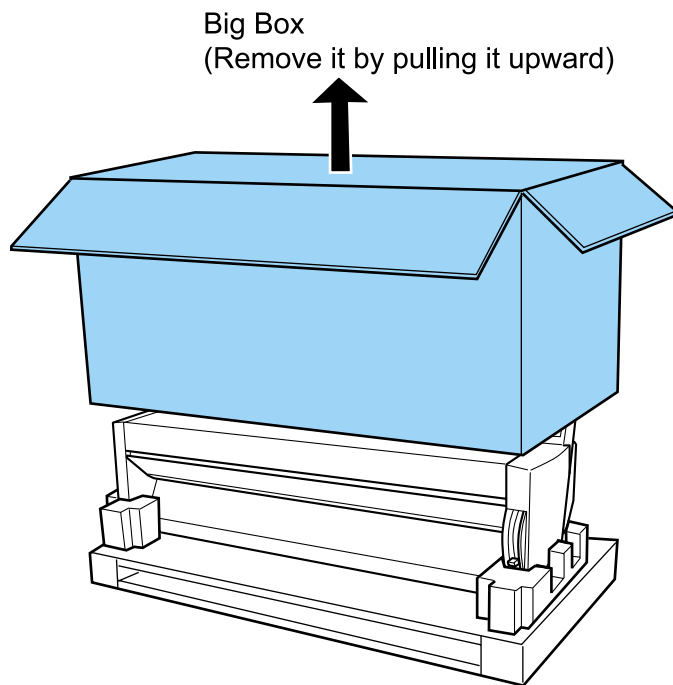

Figure 6-10. Body Assembly 3

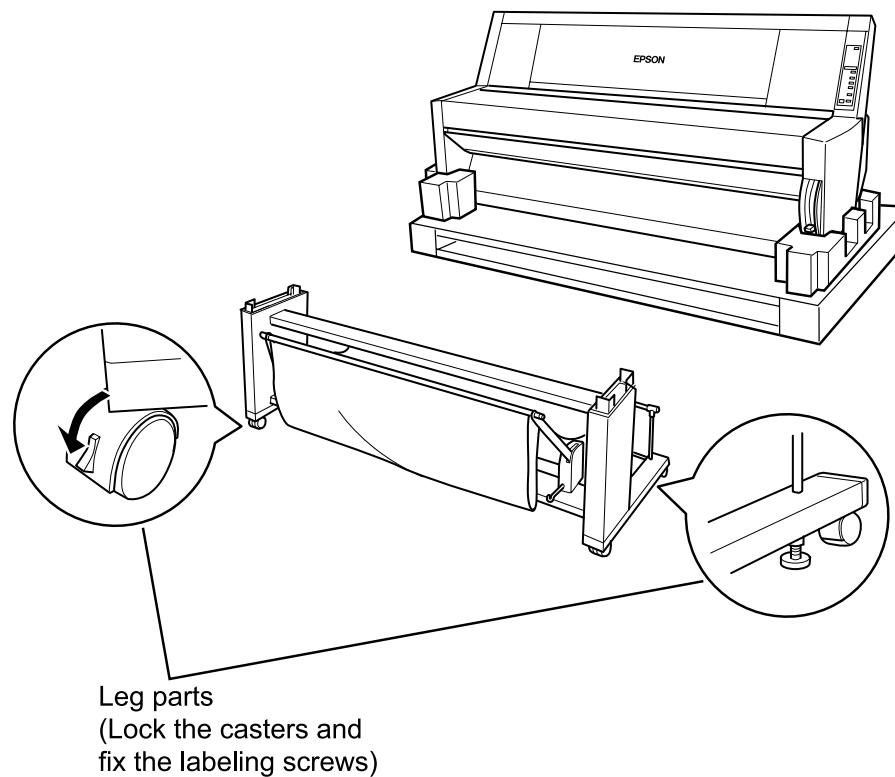

Figure 6-11. Body Assembly 4

5. Use 4 or more persons to lift the printer body and set it on the stand as shown in the figure. When setting the printer, tilt its body toward the front and set it on the stand so that the bottom front of the body catches on the hook shaped coupling in the top of the stand, then place the bottom rear of the body so that the coupling guide pins on the stand insert into the body.



- **Lifting the printer requires four people, and all four people need to lift the printer by the hand position while supporting/steadying the printer with their free hands.**
- **After placing the printer on the stand, one person should support the printer for safety's sake (to prevent the printer body from the possibility of toppling over).**

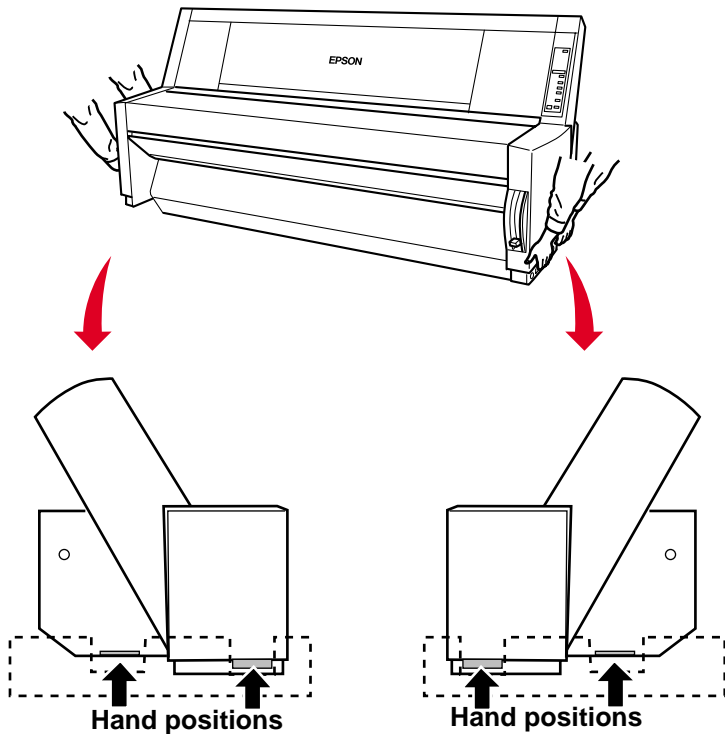

Figure 6-12. Body Assembly

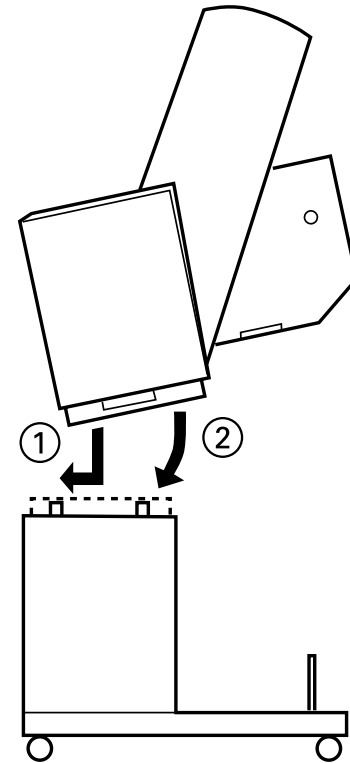

Figure 6-13. Body Assembly 6

- The couplings between the printer body and stand should be fastened securely with bolts.

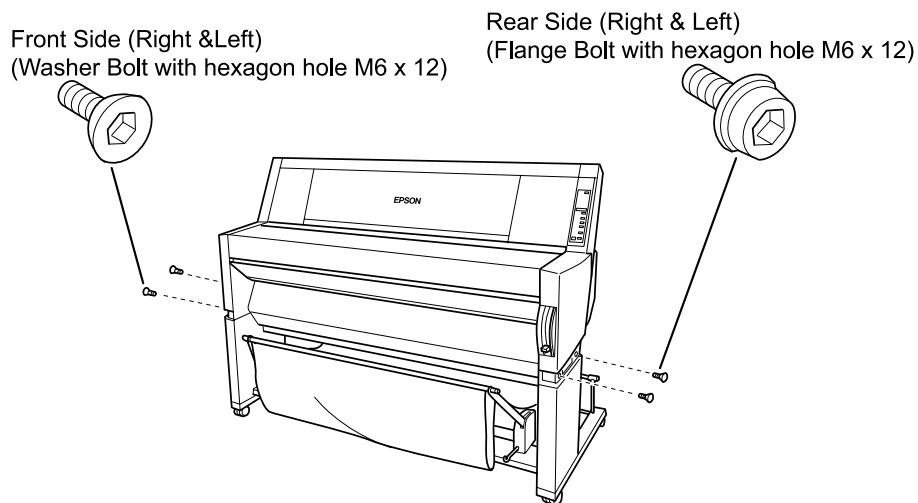

Figure 6-14. Body Assembly 7

- Install the stand covers on the stand couplings.
- After assembly is completed, release the casters and leveling screws on the stand and install the printer in its designated location. (During installation, the casters and leveling screws should be locked again.)

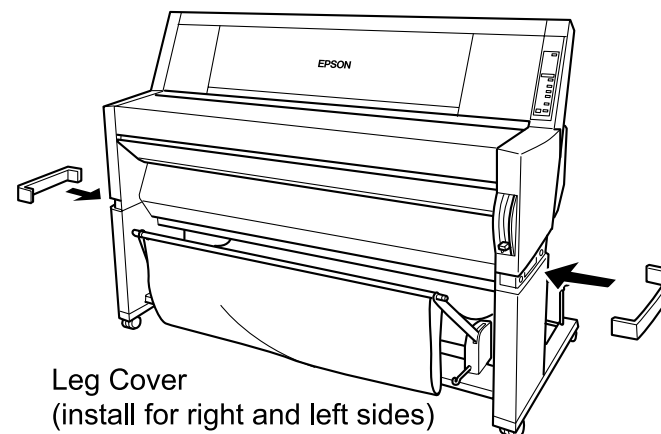

Figure 6-15. Body Assembly 8

CHAPTER

7

APPENDIX

7.1 Wiring Diagrams

The following illustration shows the connection between the printer mechanism and the electrical circuits.

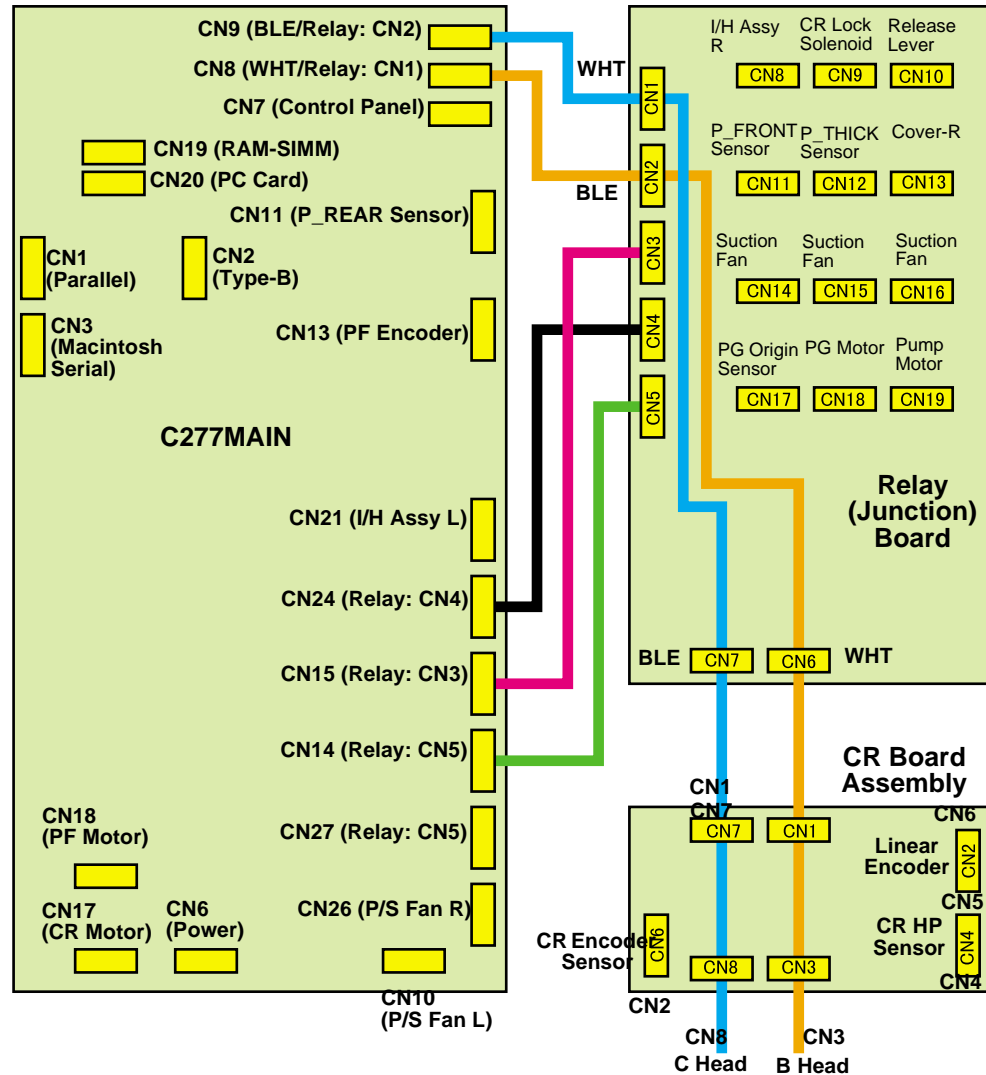

Figure 7-1. Stylus Pro 9500 Wiring Diagram

Table 7-1. Electrical Circuit Connector List

Board	Connector	Description
C277Main Board	CN1	Parallel Interface
	CN2	Type-B Option Card Connector
	CN3	Macintosh Serial Interface
	CN6	From the Power Supply Unit
	CN7	To the Control Panel
	CN8	To Relay Board/CN2:BLE
	CN9	To Relay Board/CN1:WHT
	CN10	Printer Mechanism:P/S Fan L
	CN11	Printer Mechanism:P_REAR Sensor
	CN13	Printer Mechanism:PF Encoder
	CN14	To Relay Board/CN5
	CN15	To Relay Board/CN3
	CN17	Printer Mechanism:CR Motor
	CN18	Printer Mechanism:PF Motor
	CN19	RAM-SIMM (standard)
	CN20	PC Card Slot
	CN21	Printer Mechanism:I/H Assembly L
	CN24	To Relay Board/CN4
	CN26	Printer Mechanism: P/S Fan R
	CN27	Printer Mechanism: Cover Sensor (L)

Table 7-1. Electrical Circuit Connector List (continued)

Board	Connector	Description	
Relay (Junction) Board	CN1	From C277MAIN/CN9	
	CN2	From C277MAIN/CN8	
	CN3	From C277MAIN/CN15	
	CN4	From C277MAIN/CN24	
	CN5	From C277MAIN/CN14	
	CN6	To CR Board/CN1:WHT	
	CN7	To CR Board/CN7:BLE	
	CN8	Printer Mechanism:I/H Assembly R	
	CN9	Printer Mechanism:CR Lock Solenoid	
	CN10	Printer Mechanism:Release Lever	
	CN11	Printer Mechanism:P_FRONT Sensor	
	CN12	Printer Mechanism:P_THICK Sensor	
	CN 13	Printer Mechanism:Cover Sensor	
	CN14-16	Printer Mechanism:Suction Fan	
	CN17	Printer Mechanism:PG Origin Sensor	
	CN18	Printer Mechanism:PG Motor	
	CN19	Printer Mechanism:Pump Motor	
	CR Board	CN1	From Relay Board/CN6:WHT
		CN2	CR Encoder
CN3		B Head	
CN4		CR HP Sensor	
CN6		Cutter Solenoid	
CN7		From Relay Board/CN7:BLE	
CN8		C Head	

7.2 Connector Pin Assignments

The pin layouts of the connectors on each board are shown in the following tables.

7.2.1 C277MAIN Board

CN6

Pin	Signal Name	Explanation
1	+5V	Power Supply (Logic Power Supply / 5 V)
2	GND	Ground (Logic)
3	SW	Power Switch Start Signal
4	-2V	Head Drive Voltage Generator Circuit Internal Reference Voltage (Common driver)
5	PG	Ground (Chassis)
6	+42V	Power Supply (+42 V)
7	+5V	Power Supply (Logic power supply / 5 V)
8	GND	Ground (Logic)
9	GND	Ground (Logic)
10	+28	VPower Supply (+28 V)
11	PG	Ground (Chassis)
12	+42	VPower Supply (+42 V)

CN7

Pin	Signal Name	Explanation
1	FG	Ground (Chassis)
2	FG	Ground (Chassis)
3	POWER_SW	Power Switch Signal
4	P-REV	
5	/OE	OE (Output Enable) Signal

Pin	Signal Name	Explanation
6	/RESET	Reset Signal
7	/RD	Read Signal
8	WRL	Write Signal
9		
10		
11	BA2	
12	BA1	
13	PD7	Data Signal (bit 8)
14	PD6	Data Signal (bit 7)
15	PD5	Data Signal (bit 6)
16	PD4	Data Signal (bit 5)
17	PD3	Data Signal (bit 4)
18	PD2	Data Signal (bit 3)
19	PD1	Data Signal (bit 2)
20	PD0	Data Signal (bit 1)
21-23	+5V	Power Supply (+5 V)
24-28	GND	Ground (Logic)

CN8

Pin	Signal Name	Explanation
1/4/6/8/10/12/ 14/16/18/20/ 22/24/26	GND	Ground
2	HDTEMPB	Thermistor Output (B Head)
3	HDTEMPC	Thermistor Output (C Head)
5/7/9	BHDA2/1/0	Nozzle Select Data (B Head)
11	BHCK	Synch Clock Signal (B Head)
13	BHLAT	Data Latch Signal (B Head)
15	BHNCHG	NCHG Signal (B Head)

Pin	Signal Name	Explanation
17/19/21	CHDA2/1/0	Nozzle Select Data (C Head)
23	CHCK	Synch Clock Signal (C Head)
25	CHLAT	Data Latch Signal (C Head)
27	CHNCHG	NCHG Signal (C Head)
28/29	+5V	+5V Power Supply
30	ENG_STAR	Energy-Star Mode Control Signal

CN9

Pin	Signal Name	Explanation
1/30	GND	Ground
2-9	INKS(0-7)	I/H Assembly Sensor Information (R side)
10/11	INKR_SEL1/2	P_FRONT Sensor Output
12	P_FRONT	P_THICK Sensor Output
13	P_THICK	Release Lever Position Sensor Output
14	LEVEL_UP	Cover Open Sensor Signal (1)
15	COVER1	Cover Open Sensor Signal (2)
16	COVER2	PG Home Position Detection Sensor Signal
18/19	HD_SLIDE	CR Lock Solenoid Control Signal
20/21	HD_SOL	Cutter Solenoid Control Signal
22	CUT_SOL	LED Control Signal
23	P_EDGE	P_EDGE Sensor Output
24	CR_ORG	HP Sensor Output
25	-	(Not used)
26	CRENC_A/B	CR Encoder Output

CN10/26

Pin	Signal Name	Explanation
1	VCC	Power Supply
2	N.C.	
3	P/S_FAN1/2	Fan Control Signal

CN11

Pin	Signal Name	Explanation
1	A	Anode (Emitter LED Power Supply)
2	K	Cathode
3	E	Emitter (Photo Transistor Output)
4	C	Collector

CN13

Pin	Signal Name	Explanation
1	ENC_A2	Encoder Output (Phase A)
2	ENC_B2	Encoder Output (Phase B)
3	+5	Power Supply
4	GND	Ground
5	GND	Ground

CN 14

Pin	Signal Name	Explanation
1	+28V	Power Supply
2	+28V	Power Supply
3	FAN1	Paper Suction Fan (1)
4	FAN2	Paper Suction Fan (2)

Pin	Signal Name	Explanation
5	FAN53Paper Suction Fan (3)	
6	+28V	Power Supply
7	COVER_NO	Cover Closed Signal
8	COVER_NC	Cover Open Signal

CN15

Pin	Signal Name	Explanation
1	BVHV	Head Drive Voltage (B Head)
2	BVHV	Head Drive Voltage (B Head)
3	CVHV	Head Drive Voltage (C Head)
4	CVHV	Head Drive Voltage (C Head)
5	NC	(Not Used)
6	NC	(Not Used)
7	BCOMHead Drive Voltage (B Head)	
8	BCOM	Head Drive Voltage (B Head)
9	CCOM	Head Drive Voltage (C Head)
10	CCOM	Head Drive Voltage (C Head)

CN17I

Pin	Signal Name	Explanation
1		Drive Signal
2	NC	(Not Used)
3		Drive Signal

Pin	Signal Name	Explanation
4		Drive Signal
5	NC	(Not Used)
6		Drive Signal

CN21**Table 7-2.**

Pin	Signal Name	Explanation
1	GND	Ground
2	ENG_STAR	Energy-Star Mode Control Signal
3	INKS7	I/H Assembly Sensor Information
4	INKS6	I/H Assembly Sensor Information
5	INKS5	I/H Assembly Sensor Information
6	INKS4	I/H Assembly Sensor Information
7	INKS3	I/H Assembly Sensor Information
8	INKS2	I/H Assembly Sensor Information
9	INKS1	I/H Assembly Sensor Information
10	INKS0	I/H Assembly Sensor Information
11	INKL_SEL1	I/H Assembly Select Signal
12	INKL_SEL2	I/H Assembly Select Signal
13	+5V	Power Supply
14	+5V	Power Supply
15	GND	Ground
16	GND	Ground

CN24

Pin	Signal Name	Explanation
1	+28V	Power Supply
2	+28V	Power Supply
3	A	SLID Motor (A Phase)
4	/A	SLID Motor (-A Phase)
5	B	SLID Motor (B Phase)
6	/B	SLID Motor (-B Phase)
7	A	PUMP Motor (A Phase)
8	/A	PUMP Motor (-A Phase)
9	B	PUMP Motor (B Phase)
10	/B	PUMP Motor (-B Phase)

CN27

Pin	Signal Name	Explanation
1		Cover Closed Signal
2		Common Signal
3		Cover Open Signal

7.3 Parts List

Table 7-3. Parts List for Stylus PRO 9500

Block Name	Ref No.	Sales Part Code	Description
CASE BLOCK	178	1057791	LABEL,MODEL NAME
	180	1057530	LABEL,CAUTION
	181	1046617	LBEL,CUTER CHANGE;B
	182	1046619	LABEL,PAPER JAMING;B
	183	1057537	LABEL,CUT PAPER SET
	184	1046623	LABEL,ROLL PAPER SET;B
	185	1057532	LABEL,PAPER LEVER SET UP
	186	1046626	LABEL,TRANSPORT/STRAGE,LIGHT;B
	187	1046628	LABEL,TRANSPORT/STRAGE,LEFT;B
	188	1057533	LABEL,INK MODEL NUMBER,RIGHT
	189	1057534	LABEL,INK MODEL NUMBER,LEFT
	190	1046635	LABEL,CAUTION,STEEL BELT;B
	191	1045247	LABEL,CUT POSITION
	192	1045248	LABEL,VALVE OPEN AND SHUT;LIGHT
	193	1045249	LABEL,VALVE OPEN AND SHUT;LEFT
	194	1057535	LABEL,PAPER EJECT CLOTH SET
	195	1046639	LABEL,CAUTION,CUTER; B

Table 7-3. Parts List for Stylus PRO 9500

Block Name	Ref No.	Sales Part Code	Description
	196	1046641	LABEL,CAUTION PAPER COVER;B
	198	1058864	LABEL,ACCESSORY;B
	199	1058866	LABEL,MANUAL CUTTER 3;B
CONTROL CIRCUIT BOARD	200	2035331	BOARD ASSY.,MAIN
	201	2032855	SIMM
	B1	2025669	BEADS CORE
	B10	2025669	BEADS CORE
	B11	2025669	BEADS CORE
	B12	2025669	BEADS CORE
	B13	2025669	BEADS CORE
	B14	2025669	BEADS CORE
	B15	2025669	BEADS CORE
	B16	2025669	BEADS CORE
	B17	2025669	BEADS CORE
	B18	2025669	BEADS CORE
	B19	2025669	BEADS CORE
	B2	2025669	BEADS CORE
	B20	2025669	BEADS CORE
	B21	2025669	BEADS CORE
	B22	2025669	BEADS CORE
	B23	2025669	BEADS CORE
	B24	2025669	BEADS CORE
	B25	2025669	BEADS CORE
	B26	2025669	BEADS CORE
	B27	2025669	BEADS CORE

Table 7-3. Parts List for Stylus PRO 9500

Block Name	Ref No.	Sales Part Code	Description
	B28	2028186	BEADS CORE ACB1608M-120T
	B3	2025669	BEADS CORE
	B4	2025669	BEADS CORE
	B5	2025669	BEADS CORE
	B6	2025669	BEADS CORE
	B7	2025669	BEADS CORE
	B8	2025669	BEADS CORE
	B9	2025669	BEADS CORE
	BAT1	2012596	LITHIUM BATTERY
	BAT1	2027639	BATTERY HOLDER
	C104	2023404	ALUMINIUM ELECTROLYTIC CAPACITOR
	C11	2023404	ALUMINIUM ELECTROLYTIC CAPACITOR
	C126	2029065	ALMINIUM ELECTROLYTIC CAPACITOR
	C127	2029065	ALMINIUM ELECTROLYTIC CAPACITOR
	C134	2023405	ALUMINIUM ELECTOROLYTIC CAPACITOR
	C135	2023405	ALUMINIUM ELECTOROLYTIC CAPACITOR
	C157	2025212	ALMINIUM ELECTROLYTIC CAPACITOR

Table 7-3. Parts List for Stylus PRO 9500

Block Name	Ref No.	Sales Part Code	Description
	C158	2026271	ALMINIUM ELECTORLYTIC CAPACITOR
	C159	2026271	ALMINIUM ELECTORLYTIC CAPACITOR
	C197	2026271	ALMINIUM ELECTORLYTIC CAPACITOR
	C198	2026271	ALMINIUM ELECTORLYTIC CAPACITOR
	C199	2026271	ALMINIUM ELECTORLYTIC CAPACITOR
	C28	2026211	ELECTROLYTIC CAPACITOR
	C43	2026271	ALMINIUM ELECTORLYTIC CAPACITOR
	C44	2029067	ALUMINIUM ELECTROYTIC CAPACITOR
	C45	2029068	ALUMINIUM ELECTROYTIC CAPACITOR
	C46	2023404	ALUMINIUM ELECTROLYTIC CAPACITOR
	C50	2026211	ELECTROLYTIC CAPACITOR
	C58	2026211	ELECTROLYTIC CAPACITOR
	C59	2026211	ELECTROLYTIC CAPACITOR

Table 7-3. Parts List for Stylus PRO 9500

Block Name	Ref No.	Sales Part Code	Description
	C67	2026211	ELECTROLYTIC CAPACITOR
	C71	2023404	ALUMINIUM ELECTROLYTIC CAPACITOR
	C8	2029066	ALUMINIUM ELECTROLYTIC CAPACITOR
	C83	2023404	ALUMINIUM ELECTROLYTIC CAPACITOR
	CN1	2013284	CONNECTOR 57RE-40360-830B(D7B)
	CN10	X600440310	CONNECTOR
	CN11	X600440410	CONNECTOR
	CN12	2024315	CONNECTOR
	CN13	2029071	CONNECTOR
	CN14	2006608	CONNECTOR
	CN15	X600441000	CONNECTOR
	CN17	X600720320	CONNECTOR
	CN18	2023764	CONNECTOR
	CN19	2015128	CONNECTOR
	CN19	2029079	CONNECTOR
	CN2	2007160	CONNECTOR
	CN20	2029080	CONNECTOR
	CN21	2029073	CONNECTOR
	CN24	2019814	CONNECTOR
	CN26	X600440310	CONNECTOR
	CN27	2022864	CONNECTOR
	CN3	2024322	CONNECTOR
	CN6	2015587	CONNECTOR

Table 7-3. Parts List for Stylus PRO 9500

Block Name	Ref No.	Sales Part Code	Description
	CN7	2033826	CONNECTOR
	CN8	2033825	CONNECTOR
	CN9	2033825	CONNECTOR
	CR1	2029053	QUARTZ OSCILLATOR
	CR2	X504013500	QUARTZ OSCILLATOR
	CRU1	2025626	QUARTZ OSCILLATOR
	D1	X325010309	DIODE
	D10	X325010309	DIODE
	D14	2021266	DIODE
	D15	2021266	DIODE
	D16	2021266	DIODE
	D17	2021266	DIODE
	D18	2021266	DIODE
	D19	2021266	DIODE
	D2	2002872	DIODE
	D20	2021266	DIODE
	D21	2021266	DIODE
	D22	X325010309	DIODE
	D23	2029050	DIODE
	D8	X325010309	DIODE
	D9	2029050	DIODE
	DM1	2029051	DIODE STACK
	DM2	2017557	DIODE
	DM3	2017557	DIODE
	DM4	2017557	DIODE
	DM5	2017557	DIODE
	DM6	2017557	DIODE
	F1	2026445	FUSE

Table 7-3. Parts List for Stylus PRO 9500

Block Name	Ref No.	Sales Part Code	Description
	F2	2026445	FUSE
	FL1	2006284	CHIP RESISTOR
	FL2	2026432	NOISE FILTER
	FLS1	2026262	3-TERMINAL CAPACITOR
	FLS2	2026262	3-TERMINAL CAPACITOR
	FLS3	2026262	3-TERMINAL CAPACITOR
	FLS4	2026262	3-TERMINAL CAPACITOR
	HT1	1043614	HEAT SINK
	HT2	1038574	HEAT SINK
	HT3	1038574	HEAT SINK
	IC1	2032629	FLASH ROM
	IC10	2025624	BICMOS
	IC11	X422350089	TTL-IC
	IC12	X422350329	TTL-IC
	IC13	2029040	GATE ARRAY
	IC15	2026115	REGULATOR
	IC16	2024977	TIMER IC
	IC17	X422350069	TTL-IC SN74LS06NS-TPL
	IC18	2025537	DRAM
	IC19	2025537	DRAM
	IC2	2032629	FLASH ROM
	IC20	2029039	PIO
	IC23	X422350079	TTL-IC
	IC24	X422350029	TTL IC
	IC25	2021049	I/F IC,SN75LBC775
	IC26	2021165	TTL IC,SN74ACT1284NS-EL
	IC27	2021165	TTL IC,SN74ACT1284NS-EL

Table 7-3. Parts List for Stylus PRO 9500

Block Name	Ref No.	Sales Part Code	Description
	IC28	2021165	TTL IC,SN74ACT1284NS-EL
	IC30	2022234	HIC
	IC31	2022234	HIC
	IC32	2029041	GATE ARRAY
	IC33	2029045	DRIVER
	IC34	X422350749	TTL-IC
	IC35	2029045	DRIVER
	IC36	X440003394	COMPARATOR
	IC37	2027732	D/A CONVERTER
	IC39	2025622	SRAM
	IC40	2029046	OPAMP
	IC41	2029048	FET
	IC42	2029048	FET
	IC43	2029048	FET
	IC45	2026222	OPEAMP
	IC46	2026222	OPEAMP
	IC47	X422352459	TTL SN74LS245NS-TPL
	IC48	2029047	OPAMP
	IC49	X462701438	C-MOS IC
	IC50	X422350089	TTL-IC
	IC51	2008099	TTL-IC
	IC52	2029048	FET
	IC53	X422352449	TTL IC
	IC7	2023625	RESET IC
	IC8	2030464	CPU
	IC9	2034172	IC
	LA1	2029070	RELAY

Table 7-3. Parts List for Stylus PRO 9500

Block Name	Ref No.	Sales Part Code	Description
	LA2	2029070	RELAY
	LED1	2029052	LED
	LED2	2029052	LED
	LED3	2029052	LED
	LED4	2029052	LED
	LED5	2029052	LED
	LED6	2029052	LED
	LED7	2029052	LED
	LED8	2029052	LED
	Q1	2017978	TRANSISTOR
	Q10	2026213	TRANSISTOR
	Q11	2024208	TRANSISTOR
	Q12	2024209	TRANSISTOR
	Q13	2024208	TRANSISTOR
	Q14	2024209	TRANSISTOR
	Q15	2011623	TRANSISTOR
	Q18	X304168109	TRANSISTOR
	Q19	2029049	TRANSISTOR
	Q2	2029049	TRANSISTOR
	Q20	2029049	TRANSISTOR
	Q21	2011623	TRANSISTOR
	Q3	2026214	TRANSISTOR
	Q4	2026213	TRANSISTOR
	Q5	2024208	TRANSISTOR
	Q6	2024209	TRANSISTOR
	Q7	2024208	TRANSISTOR
CONTROL CIRCUIT BOAR	Q8	2024209	TRANSISTOR

Table 7-3. Parts List for Stylus PRO 9500

Block Name	Ref No.	Sales Part Code	Description
	Q9	2026214	TRANSISTOR
	QM1	2022823	TRANSISTOR
	SWD1	2029069	DIP SWITCH
	TH1	2026536	CHIP THERMISTOR
	TH2	2026536	CHIP THERMISTOR
	VR1	2035328	POTENTIOMETERS
	VR2	2035329	POTENTIOMETERS
	VR3	2035329	POTENTIOMETERS
CABLE BLOCK	400	2032091	P/S CABLE(EAI 120V)
PRINTER MECHANISM	101	1044247	X REDUCTION BELT
	102	1044248	ROLL SUPPORT L,ASSY
	103	1044249	ROLL SUPPORT R,ASSY
	104	1044250	COVER SUPPORT ASSY
	105	2037179	PF MOTOR PULLEY ASSY
	106	1044252	AIR SHIELD A
	107	1044253	AIR SHIELD B
	108	1044254	VACUUM FAN ASSY
	109	1044255	FAN DUCT
	110	1044256	VACUUM FAN 1 CABLE ASSY
	111	1044257	VACUUM FAN 2 CABLE ASSY
	112	1044258	VACUUM FAN 3 CABLE ASSY
	115	1044261	COVER DUMPER ASSY
	116	2030087	TERM BOARD ASSY
	117	2030088	LEVER DETECTOR ASSY
	118	1044264	PRESS TRANSMISSION GEAR

Table 7-3. Parts List for Stylus PRO 9500

Block Name	Ref No.	Sales Part Code	Description
	119	1044265	PRESS TRANSMISSION GEAR
	120	1044266	COVER R DETECTOR ASSY
	121	1044267	HD SLIDE DETECTOR ASSY
	122	1044268	SLIDE DETECTOR GUIDE
	123	1044269	SLIDE MOTOR GEAR ASSY
	124	1059725	LEVER COVER
	125	1059726	PRESS LEVER KNOB
	126	1044393	COVER L DETECTOR ASSY
	127	1044394	COVER DAMPER L ASSY
	131	1044246	POROUS PAD,INK EJECT
	157	1048898	MOUNTING PLATE,SCALE
	158	1056148	SCALE,PF
	159	1048913	TAPE,D50
	160	1059734	ENCODER FLANGE
	161	2035504	BOARD ASSY.,ENCODER
	303	F055050	PRINT HEAD,IJ192-0AE
	305	F055040	PRINT HEAD,IJ192-0AD
	203	1044274	Y DRIVEN PULLEY ASSY
	204	1044275	SCREW CAP
	205	1044276	T FENCE
	206	2030090	P THICK DETECTOR ASSY
	207	2032038	CR MOTOR,PULLEY ASSY,A
	208	1044279	DETECTOR ARM

Table 7-3. Parts List for Stylus PRO 9500

Block Name	Ref No.	Sales Part Code	Description
	209	1044285	STEEL BELT
	210	1059459	F BOX L ASSY
	211	2037041	P FRONT SENSOR ASSY
	302	1056149	DAMPER ASSY.
	304	1044288	HEAD TAPE CABLE
	306	1044290	P EDGE ASSY
	307	1044291	HEAD ADJUSTOR A
	308	1044292	HEAD ADJUSTOR B
	309	1044293	CUTTER CAP
	310	1044294	SOLONOID SPRING
	311	1044295	CUTTER SOLONOID ASSY
	312	1044296	CUTTER SPRING
	313	1044297	SLIDE ECCENTRIC CAM
	314	1044298	SLIDE GEAR
	319	1030787	COMPRESSION SPRING,9.9
	320	1054278	DAMPER STOPPER
	321	1054279	CUTTER HOLDER
	402	1044300	CR ROCK ASSY
	403	1055991	CAP ASSY.
	404	2030410	PUMP MOTOR ASSY
	405	1035836	PUMP ASSY.
	406	1033209	CLEANER,HEAD,ASP
	407	1044302	F BOX R ASSY
	411	1035198	MOUNTING PLATE,MOTOR,ASF
	412	1012618	DAMPER,CR
	413	1038605	PLANE WASHER,3.3*1.5*8,S/NA

Table 7-3. Parts List for Stylus PRO 9500

Block Name	Ref No.	Sales Part Code	Description
	414	1017596	SHAFT,DAMPER,CR;B
	415	1037461	FASTEN PLATE,MOTOR,ASF
	416	1050568	PUMP GEAR
	417	1050569	PUMP IDLE GEAR
	418	1050570	PUMP REDUCTION GEAR 1
	419	1050571	PUMP REDUCTION GEAR 2
	503	1044305	I/C COVER
	504	1035239	CAM,VALVE
	505	1044306	BULB GEAR
	506	1044307	BULB ADJUST GEAR L
	507	1044308	BULB ADJUST GEAR L
	508	1044309	I/H BULB SPRING
	509	2030092	INK BOARD ASSY
	510	2030093	HODER DETECTOR ASSY
	511	2024712	DETECTOR,INK END
	512	2030095	HODER L TAPE CABLE
	513	2030096	HOLDER R TAPE CABLE
	514	1044322	I/C LINK
	515	1044323	I/C LEVER KNOB
	516	2030097	INK ID BOARD ASSY R
	517	2030098	INK ID BOARD ASSY C
	518	2030099	INK ID BORAD ASSY L
	519	1035844	HOLDER ASSY.,VALVE,A
	520	2030100	NOT DETECTOR ASSY R
	521	2030101	NOT DETECTOR ASSY D
	522	2030102	NOT DETECTOR ASSY L

Table 7-3. Parts List for Stylus PRO 9500

Block Name	Ref No.	Sales Part Code	Description
	523	1044336	I/H LEVER L
	524	1044337	I/H LEVER KNOB L
	525	1044338	I/H LEVER R
	526	1044339	I/H LEVER KNOB R
	527	1044343	BULB KNOB
	528	1044344	BULB MANUAL CAM
	530	1044346	OIL DAMPER
	531	1044347	I/H SPACER
	532	1044348	I/H IDLE GEAR
	533	1044349	LATCH
	534	1044350	FLANGE(2 INCH)
	535	1044351	FLANGE(3 INCH)
	538	1035266	WIRE SPRING,HOLDER,IC
	539	1001468	TORSION SPRING,3490
	540	1035267	COVER,HOLDER,IC
	541	1035843	HOLDER ASSY.,IC,GUIDE
	542	1035274	LEVER,INK END
	601	2032386	CR BOARD ASSY A
	602	2030104	HEAD ORIGIN POINT DETECTOR ASSY
	603	2030105	CR ENC ASSY
	604	1051007	CR TAPE CABLE ASSY A
	606	1033483	O RING,TUBE FASTEN
	607	1033482	JOINT SCREWS,M6
	608	1033481	JOINT,BK
	612	1055999	TUBE,SUPPLY,INK,A
	613	1056000	TUBE,SUPPLY,INK,B
	614	1056001	TUBE,SUPPLY,INK,Y

Table 7-3. Parts List for Stylus PRO 9500

Block Name	Ref No.	Sales Part Code	Description
	615	1056002	TUBE,SUPPLY,INK,M
	616	1056003	TUBE,SUPPLY,INK,LM
	617	1055027	ENC SPACER (10PCS/ SET)
	618	1056004	TUBE,SUPPLY,INK,C
	619	1056005	TUBE,SUPPLY,INK,LC
	703	2030106	POWER SUPPLY BOARD ASSY
	704	2030107	P/S FAN ASSY
	705	2037042	P REAR SENSOR ASSY
	706	2030109	POWER SUPPLY DC CABLE
	707	1044361	PF MOTOR CABLE ASSY
	708	1044362	CR MOTOR CABLE ASSY
	709	1044363	STEPPING MOTOR CABLE
	710	1044364	PANEL TAPE CABLE
	711	1044365	MAIN TAPE CABLE 1
	712	1044366	MAIN TAPE CABLE 2
	713	1044367	FAN CABLE
	714	1044368	PF ENCODER CABLE ASSY
	716	1044370	HEAD COM CABLE
	717	1044396	COOLING FAN CABLE ASSY
	720	1011863	GROUNDING PLATE,I/ F,UPPER
	721	1056008	CABLE CLAMP
	801	2037181	PANEL ASSY(OVERSEAS)
	802	1057018	LOGO PLATE30X30

Table 7-3. Parts List for Stylus PRO 9500

Block Name	Ref No.	Sales Part Code	Description
	805	1059727	R SIDE COVER
	806	1059728	R STAND COVER
	807	1059731	ROLL COVER ASSY
	808	1044378	FRONT COVER ASSY
	809	1051808	NEW TYPE SUB PLATEN
	810	1051809	NEW TYPE SUB PLATEN A
	811	1051810	NEW TYPE SUB PLATEN B
	812	1059729	L SIDE COVER
	813	1059730	L STAND COVER
	814	1059732	H TOP COVER ASSY
	815	1054275	PAPER GUIDE L
	816	1054276	MAGNET CATCH
	817	1054277	PAPER GUIDE TRAY
	818	1059733	R TOP COVER
PACKING MATERIAL	NON FIG	1055028	ROLL BAND
	NON FIG	1056539	INK CARTRIDGE WITHIN INDIVIDUAL BOX,BG,L(OVERSEAS)
	NON FIG	1056540	INK CARTRIDGE WITHIN INDIVIDUAL BOX,YG,L(OVERSEAS)
	NON FIG	1056541	INK CARTRIDGE WITHIN INDIVIDUAL BOX,MG,L(OVERSEAS)
	NON FIG	1056542	INK CARTRIDGE WITHIN INDIVIDUAL BOX,CG,L(OVERSEAS)

Table 7-3. Parts List for Stylus PRO 9500

Block Name	Ref No.	Sales Part Code	Description
	NON FIG	1056543	INK CARTRIDGE WITHIN INDIVIDUAL BOX,LMG,L(OVERSEAS
	NON FIG	1056544	INK CARTRIDGE WITHIN INDIVIDUAL BOX,LCG,L(OVERSEAS
	NON FIG	1058462	MAINTENANCE KIT,STYLUS PRO 9500
	NON FIG	4010221	SUPPLEMENT
	NON FIG	4012670	UNPACKING SHEET

7.4 Exploded view Diagram

The illustrations in the following pages show the printer components and arrangement. The part numbers in the illustrations refer to the illustration numbers in Table 7-3, "Parts List for Stylus PRO 9500," on page 239.

- No.1: PF L Frame Assembly, Fan Bracket Assembly
- No.2: R Frame Assembly
- No.3: PF Rail Assembly
- No.4: CR Rail Assembly
- No.5: Carriage Assembly
- No.6: Maintenance Assembly
- No.7: I/H Assembly (1) LEFT
- No.8: I/H Assembly(1) RIGHT
- No.9: I/H Assembly(1) IH Assembly
- No.10: I/H Assembly(2) Holder
- No.11: Tube Assembly(2)
- No.12: Board Assembly
- No.13: Cover Assembly

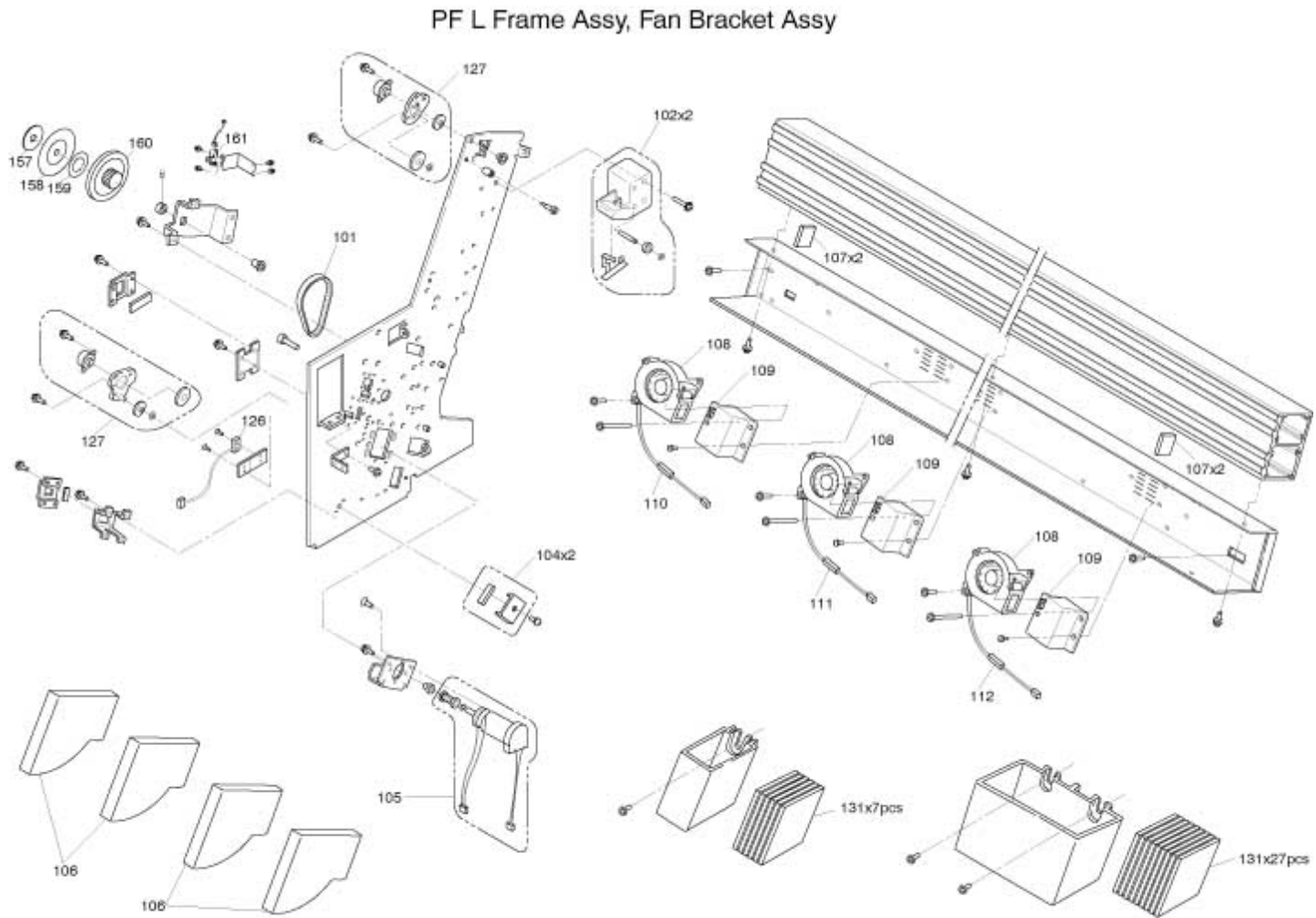

MC-9000/STYLUS PRO 9500 No.1 Rev.01 10219

Figure 7-2. PF L Frame Assembly, Fan Bracket Assembly

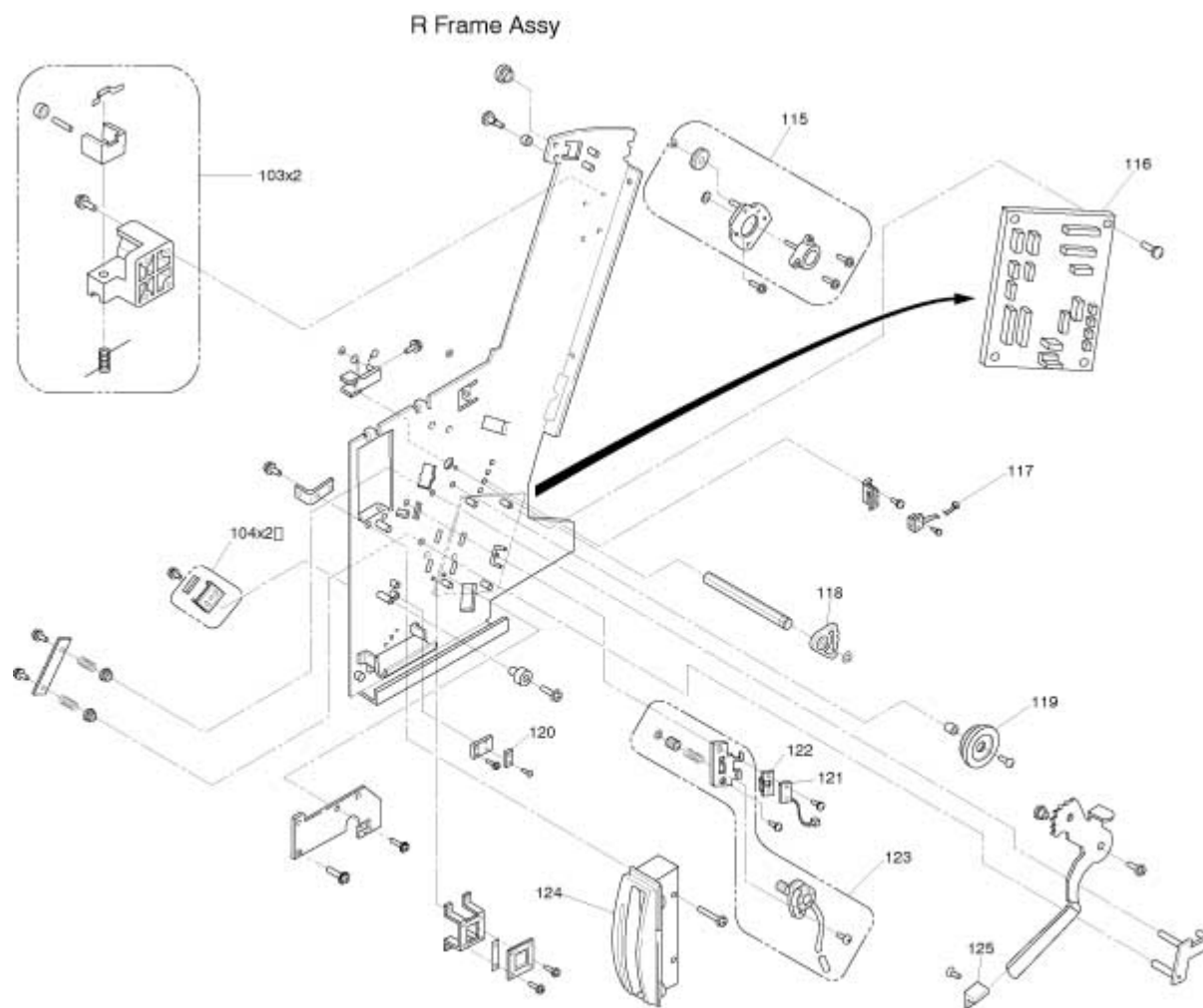

MC-9000/STYLUS PRO 9500 No.2

Rev.01 10219

Figure 7-3. R Frame Assembly

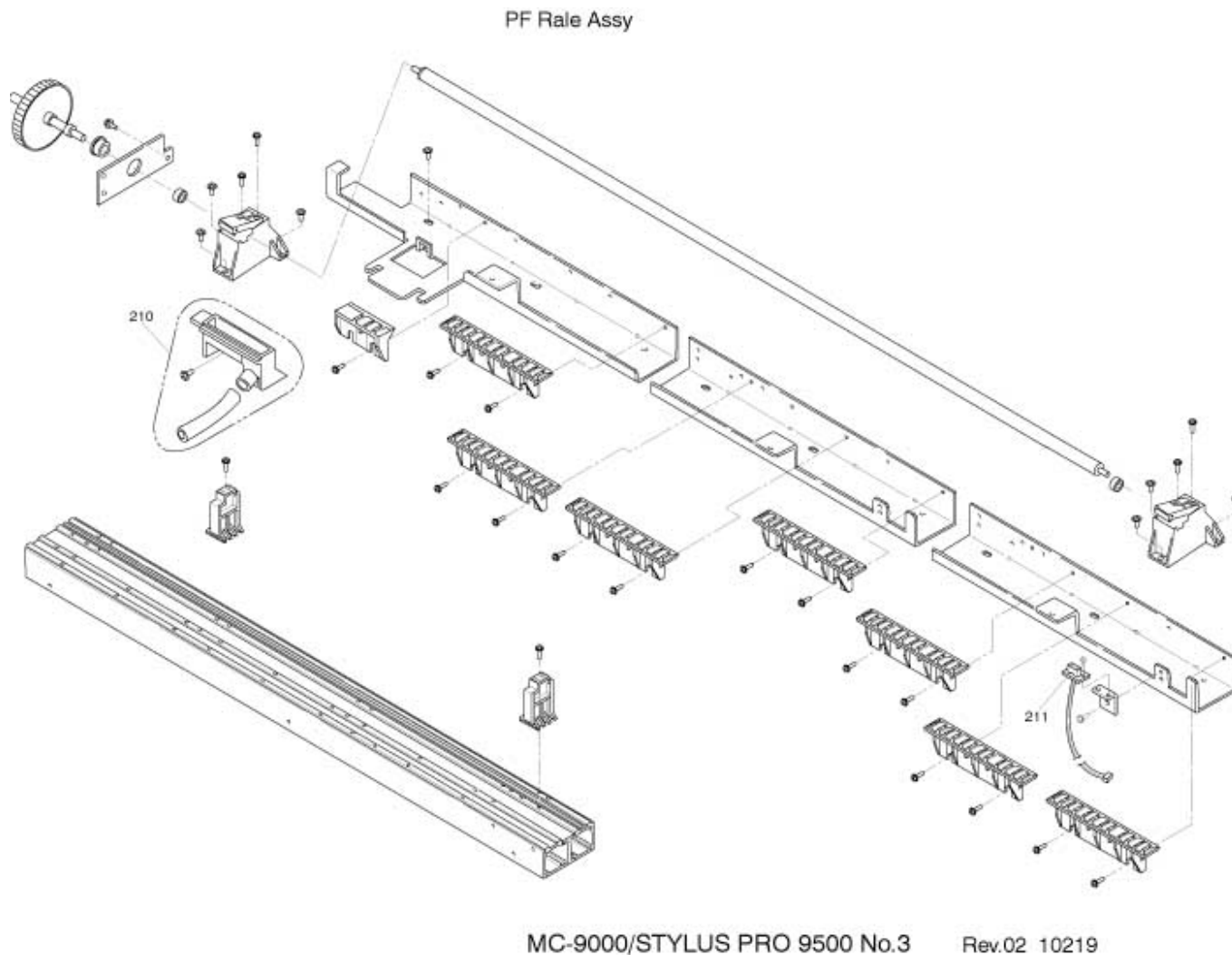
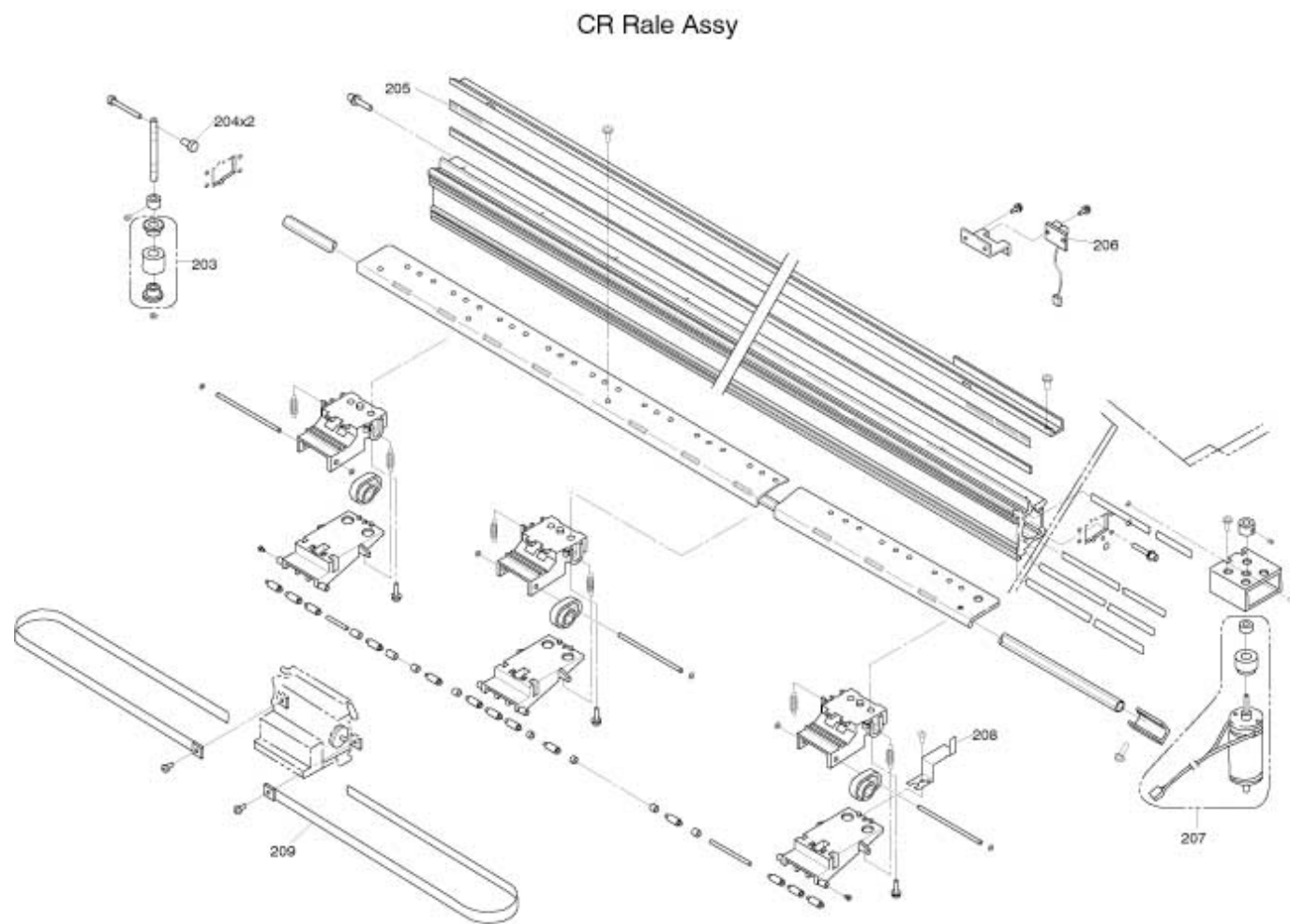

Figure 7-4. PF Rail Assembly



MC-9000/STYLUS PRO 9500 No.4 Rev.01 10219

Figure 7-5. CR Rail Assembly

Carriage Assy

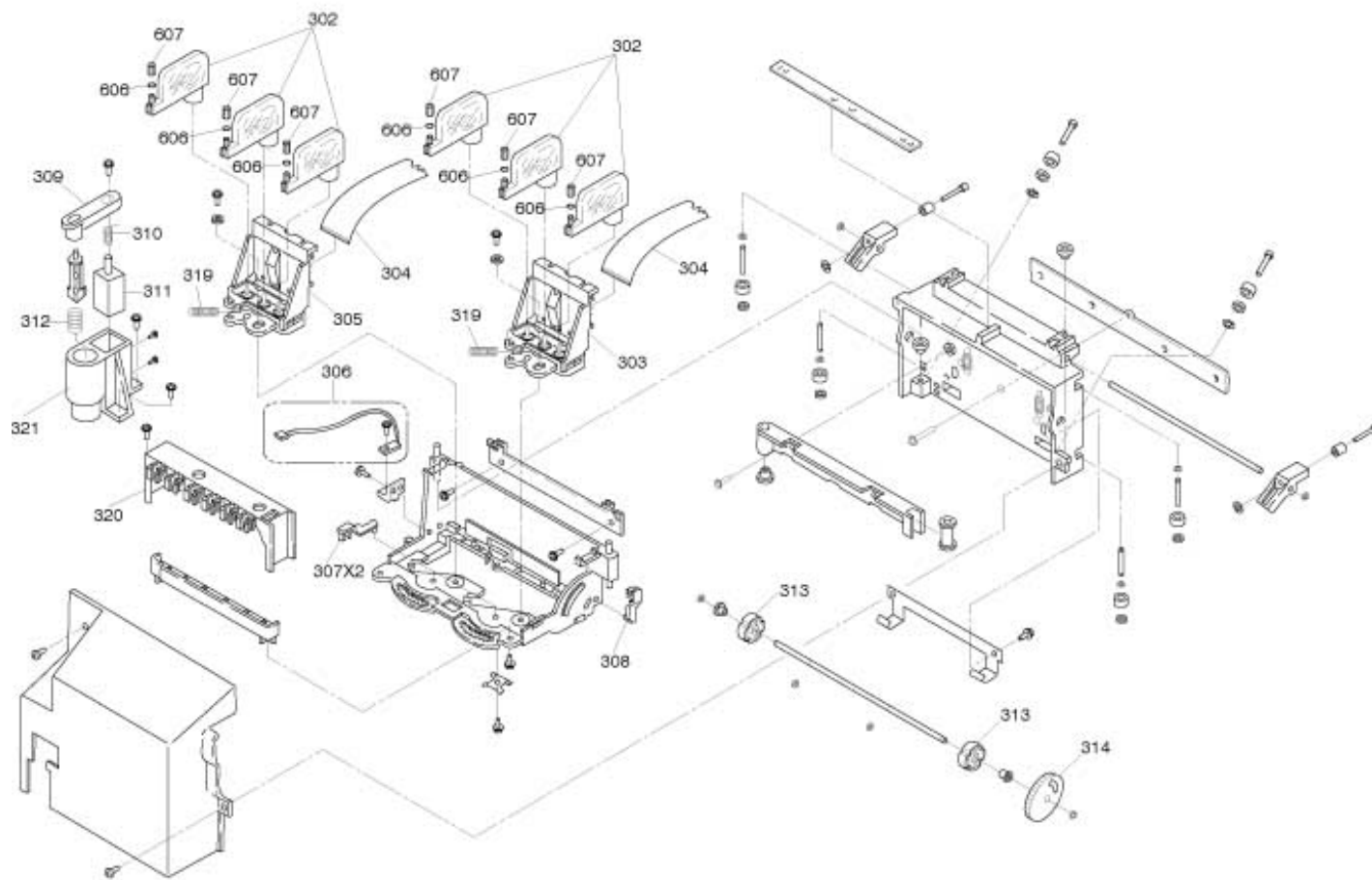

MC-9000/STYLUS PRO 9500 No.5

Rev.01 10219

Figure 7-6. CR Assy

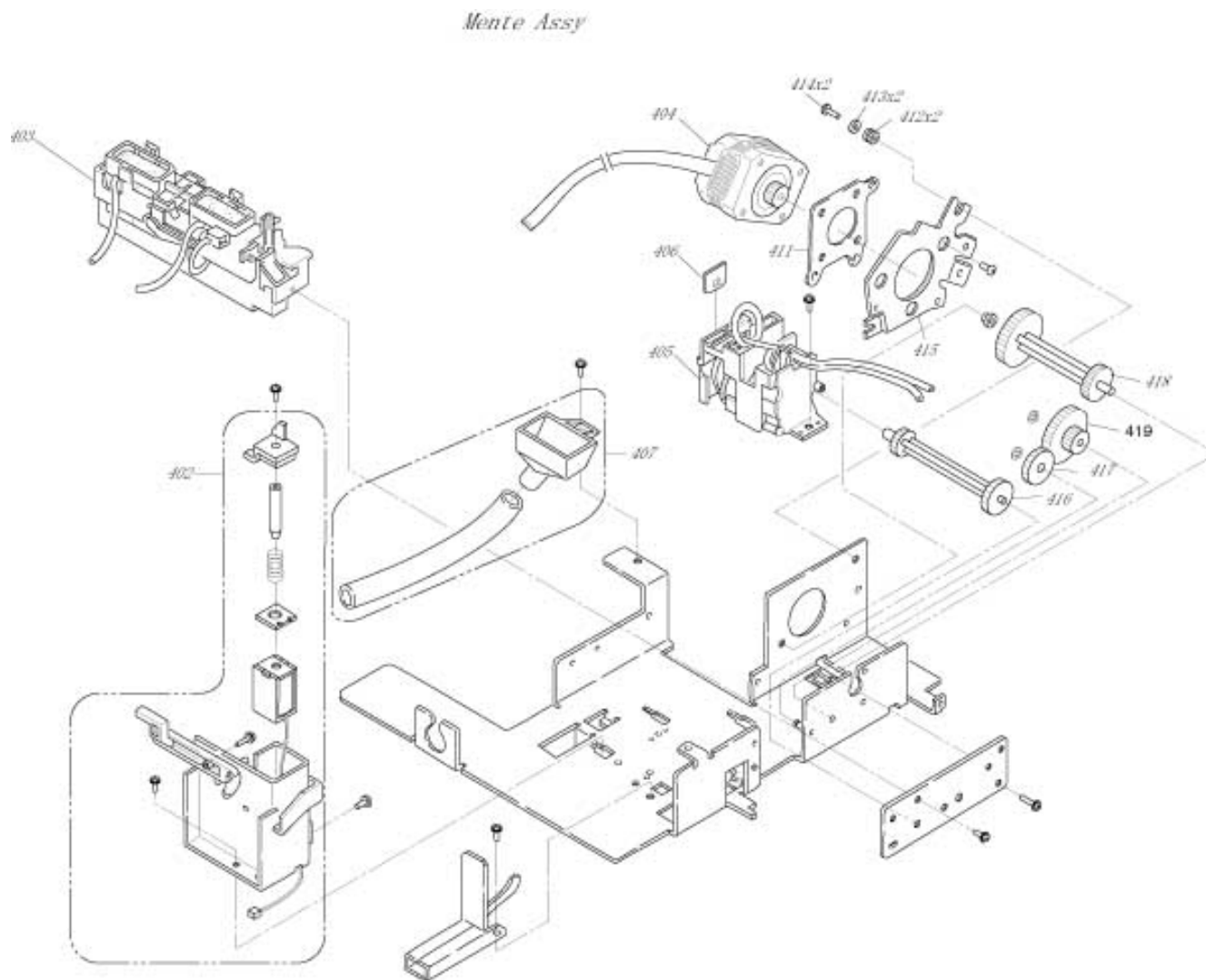

MC-9000/STYLUS PRO 9500 No.6 Rev.01 10219

Figure 7-7. Maintenance Assy

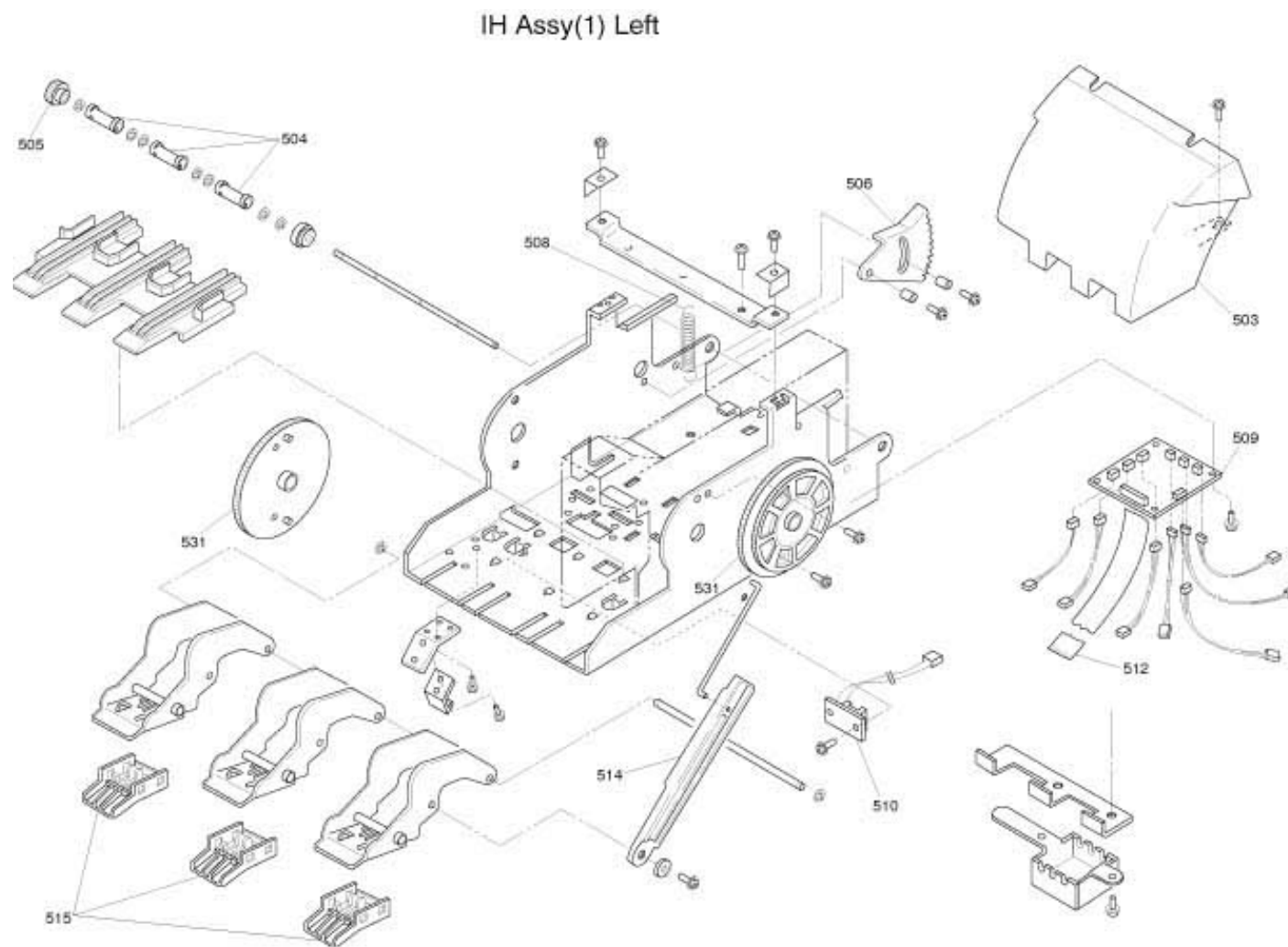

MC-9000/STYLUS PRO 9500 No.7

Rev.01 10219

Figure 7-8. I/H Assy Left

I/H Assy(1) Right

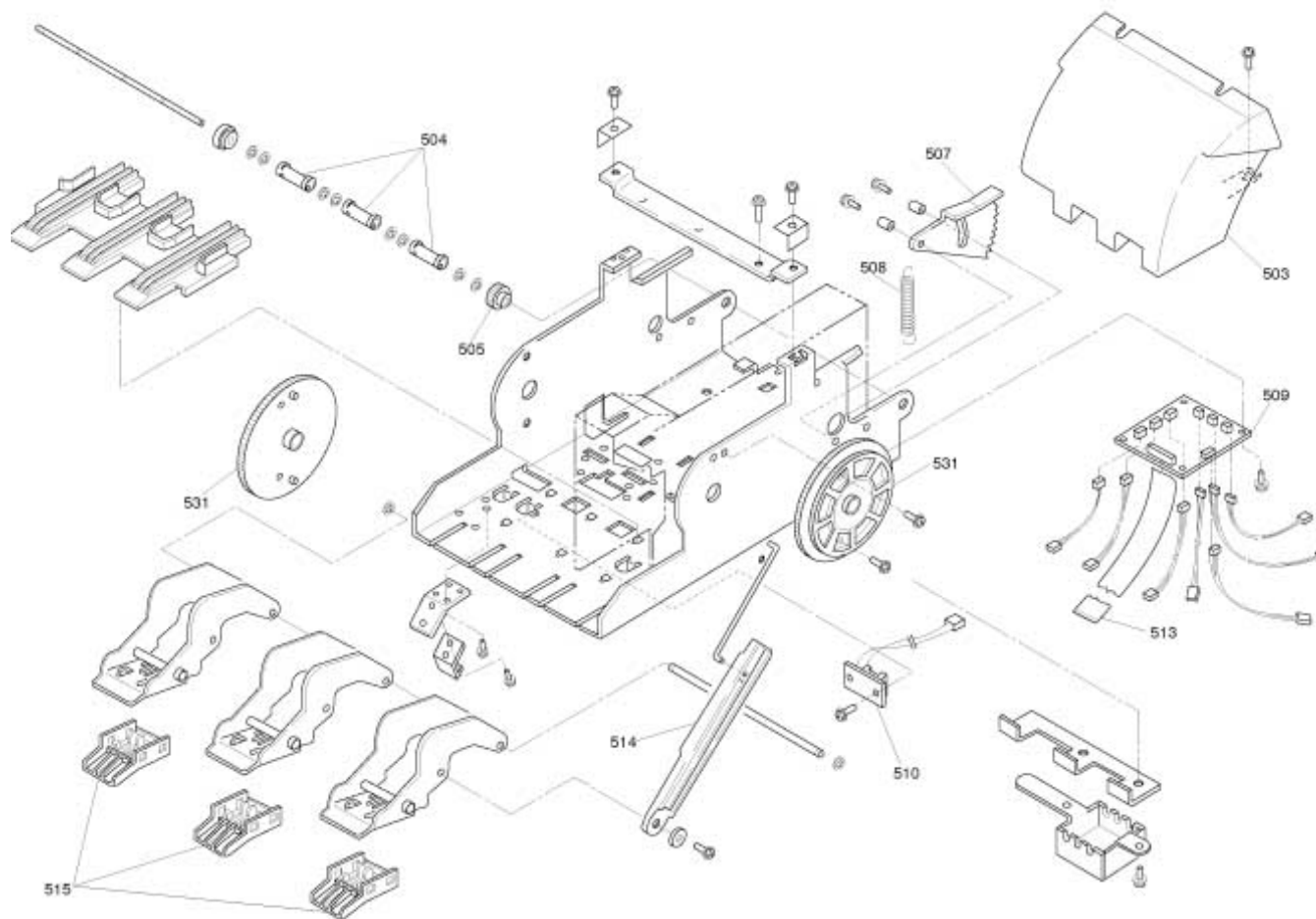

MC-9000/STYLUS PRO 9500 No.8 Rev.01 10219

Figure 7-9. I/H Assy Right

I/H Assy(1)

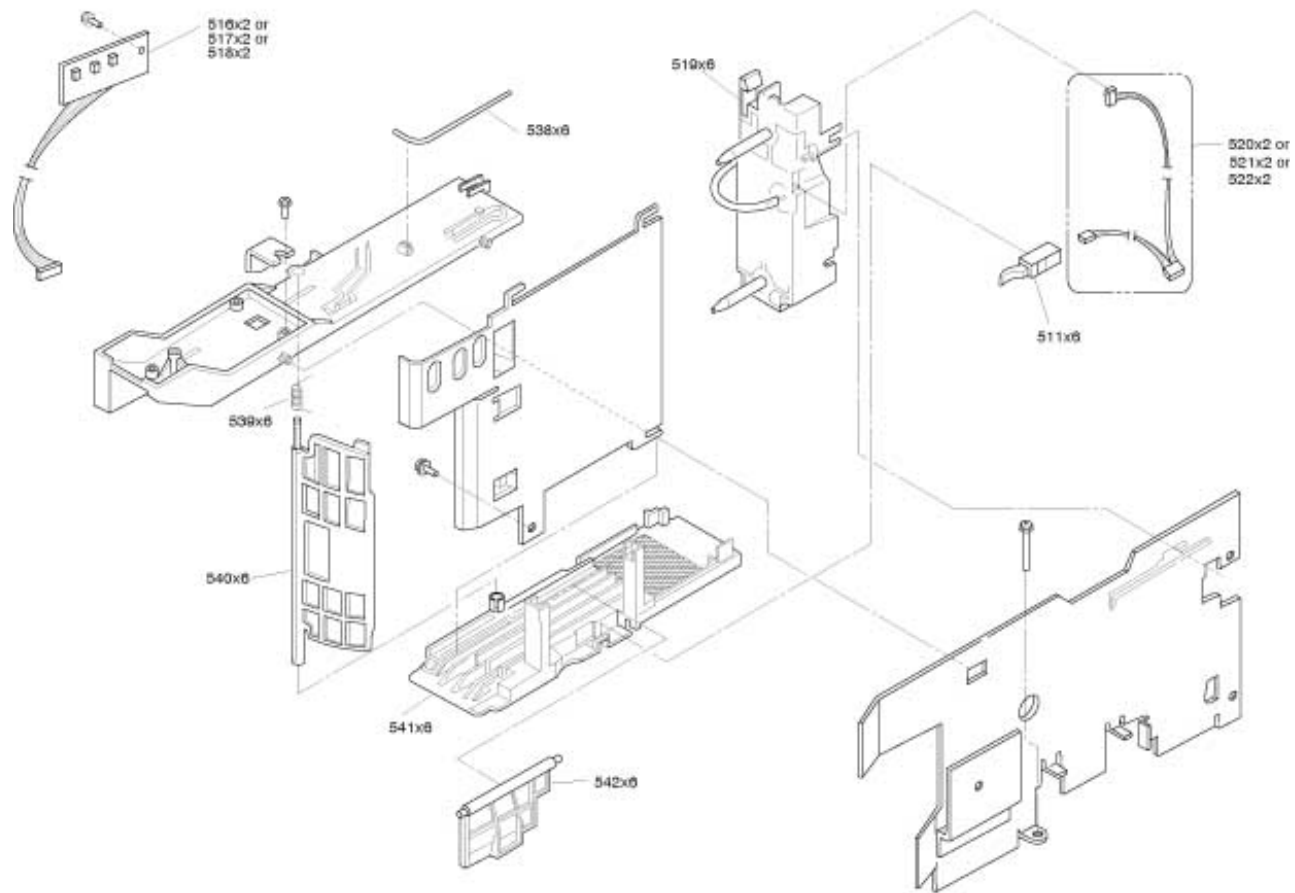

MC-9000/STYLUS PRO 9500 No.9

Rev.01 10219

Figure 7-10. I/H Assy (1)

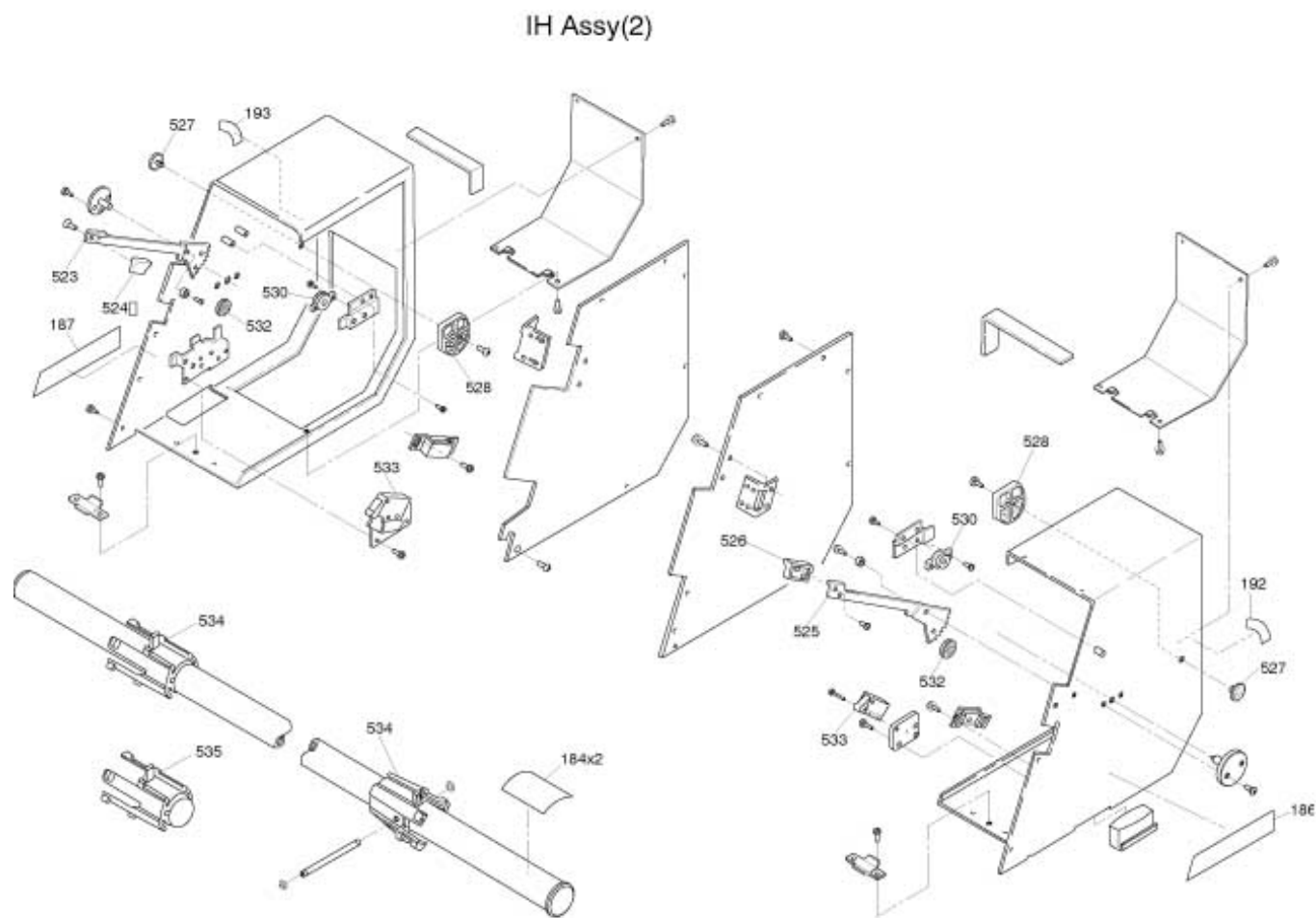

MC-9000/STYLUS PRO 9500 No.10 Rev.01 10219

Figure 7-11. I/H Assy (2)

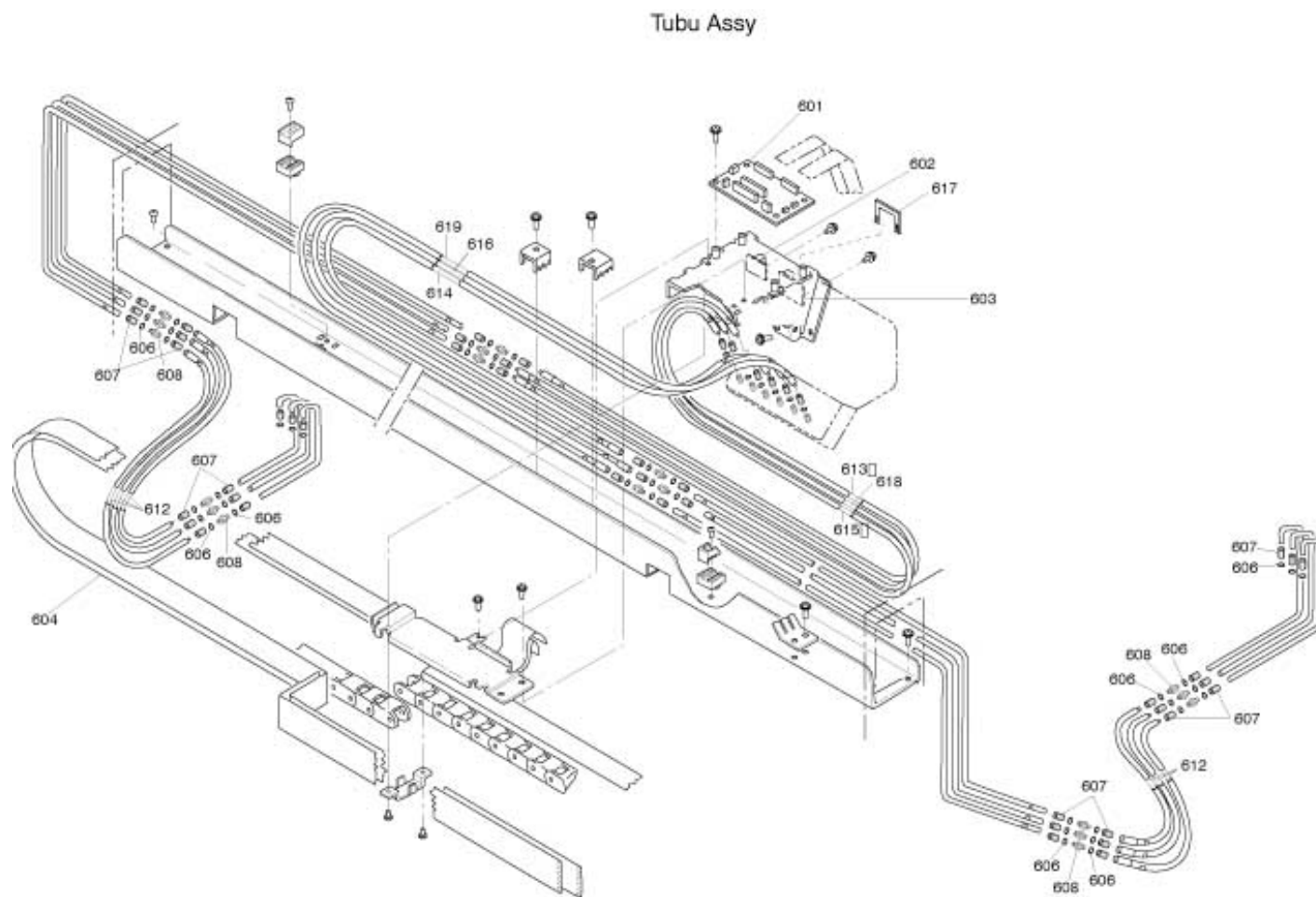

MC-9000/STYLUS PRO 9500 No.11 Rev.01 10219

Figure 7-12. Tube Assembly

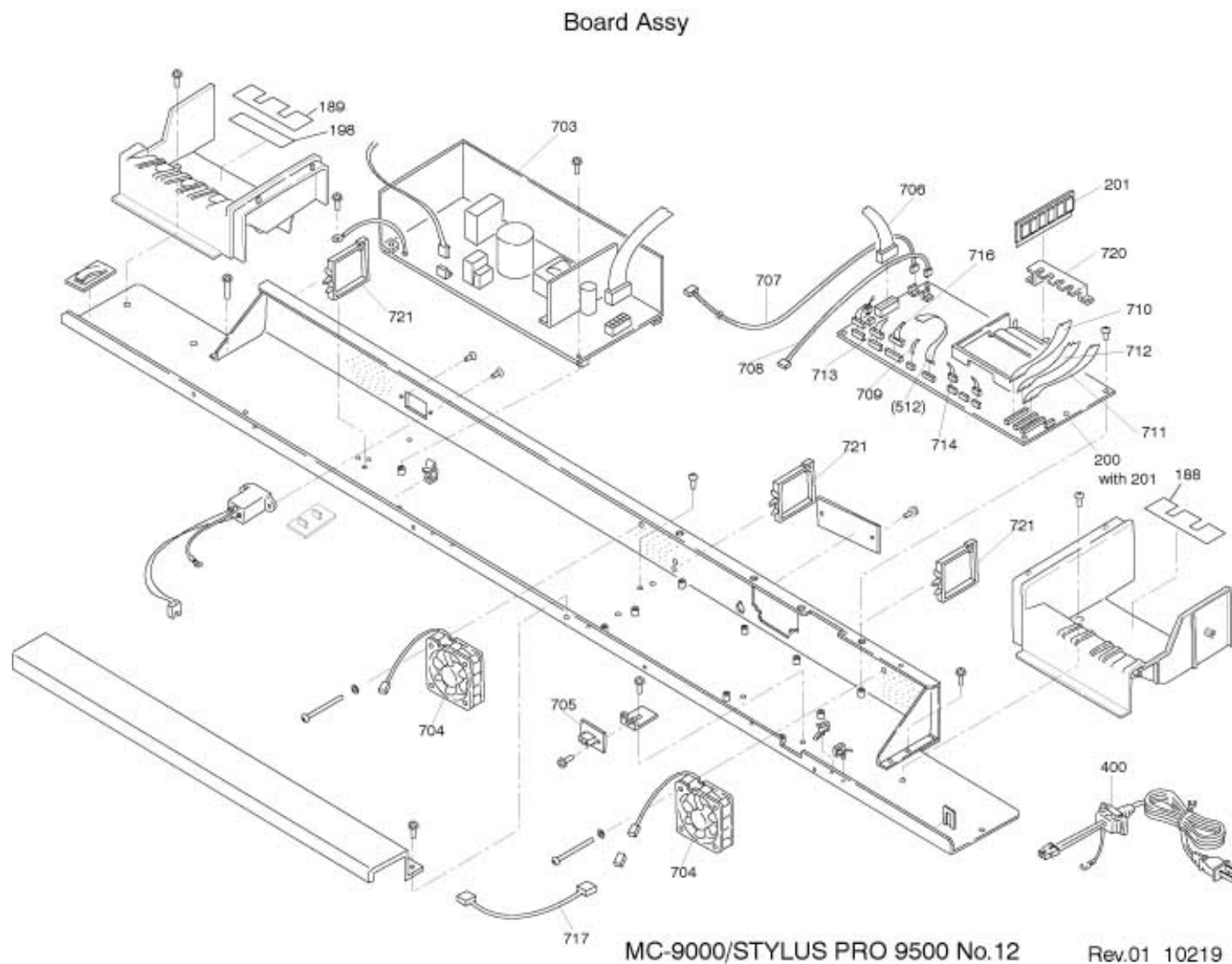

Figure 7-13. Board Assembly

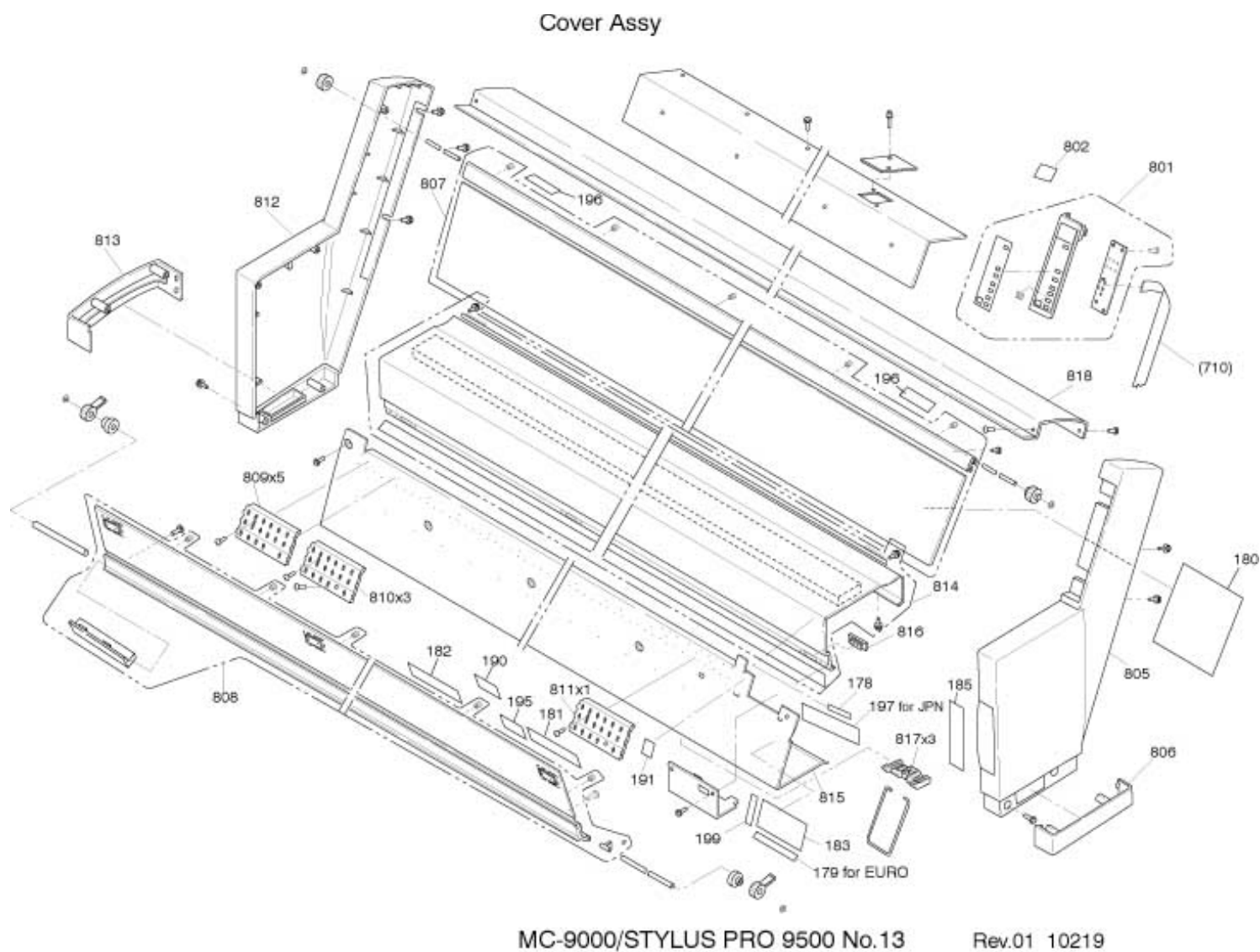
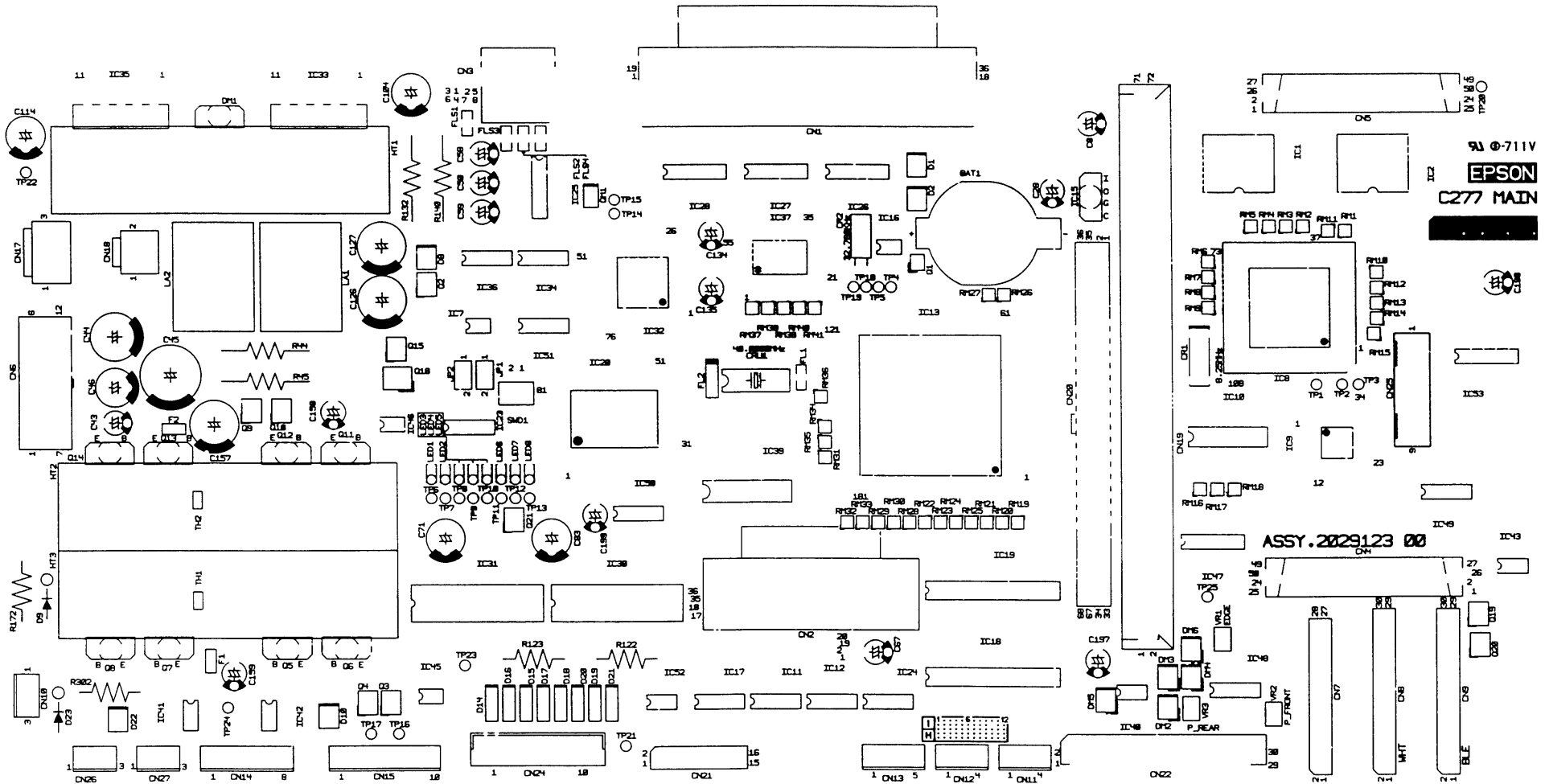

Figure 7-14. Cover Assembly

7.5 Component Layout

This illustrations below show the C277 Main board component layout.



The illustrations below show the C277 MAIN Board component layout.

Figure 7-15. C277MAIN Board Component Layout of Component side

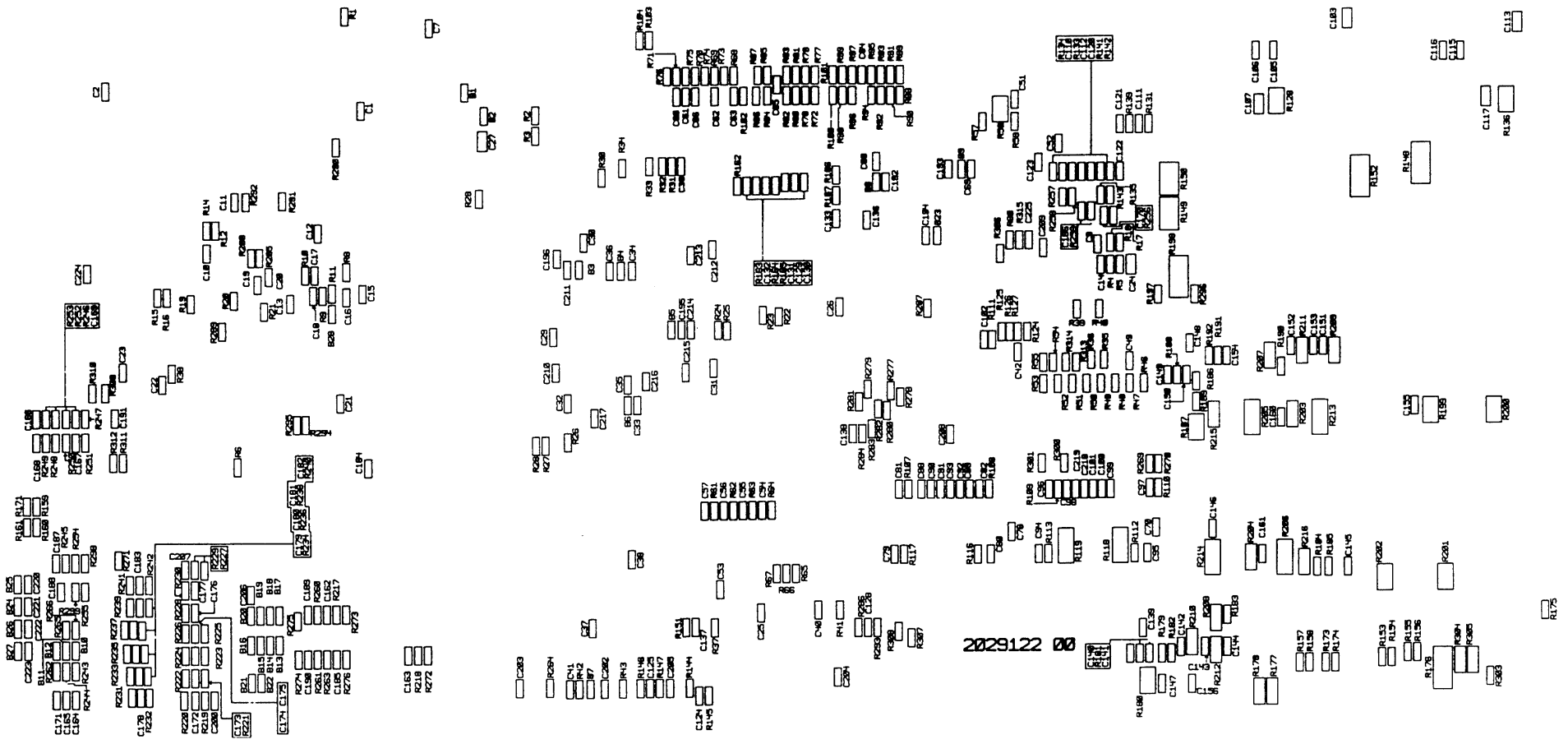
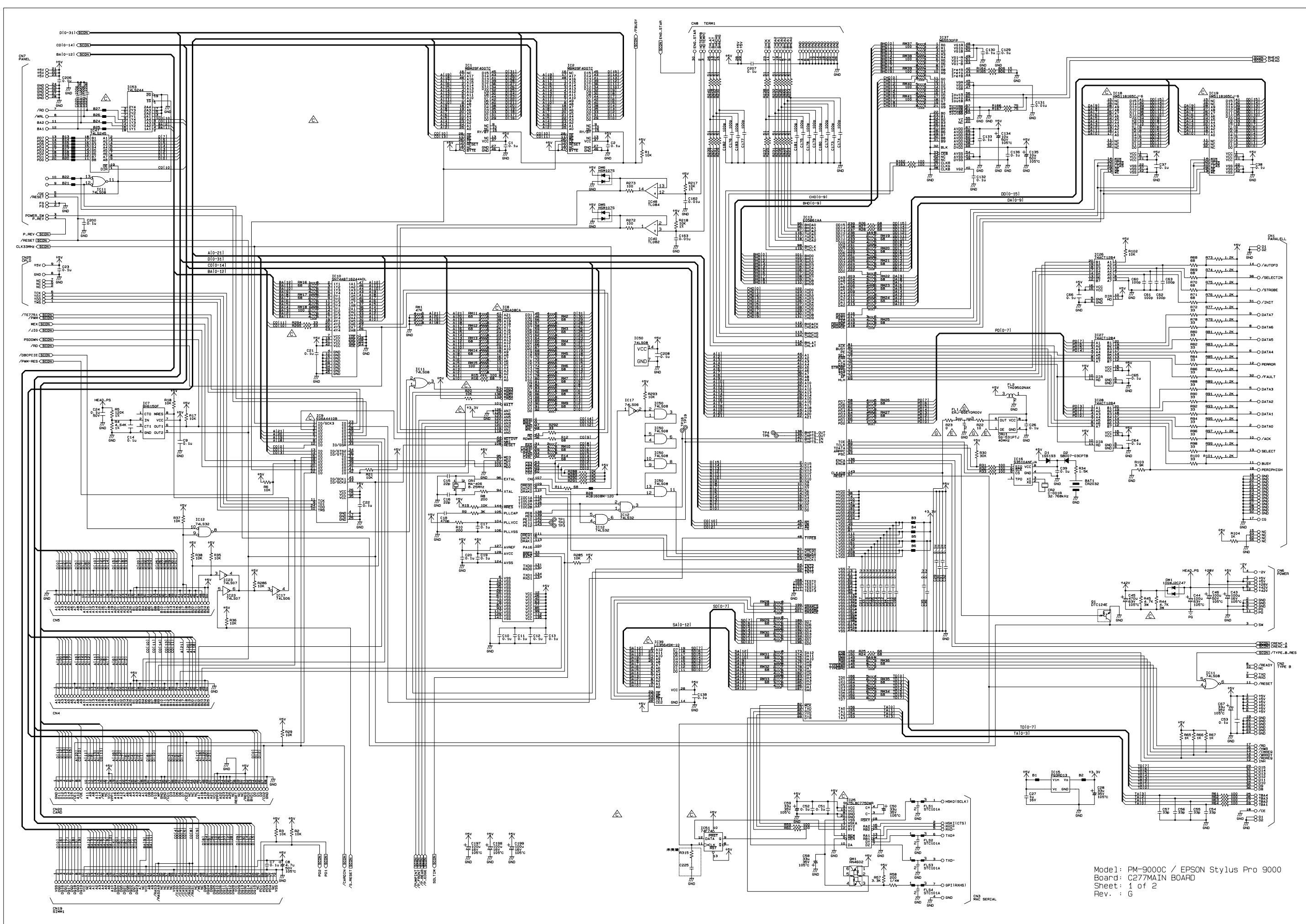

Figure 7-16. C277MAIN Board Component Layout of Soldering Side

7.6 Circuit Diagrams

The circuit diagrams for the C277MAIN Board are provided in the following pages.

- C277MAIN (1/2)
- C277MAIN (2/2)



Model: PM-9000 / EPSON Stylus Pro 9000
 Board: C277MAIN BOARD
 Sheet: 1 of 2
 Rev.: 6

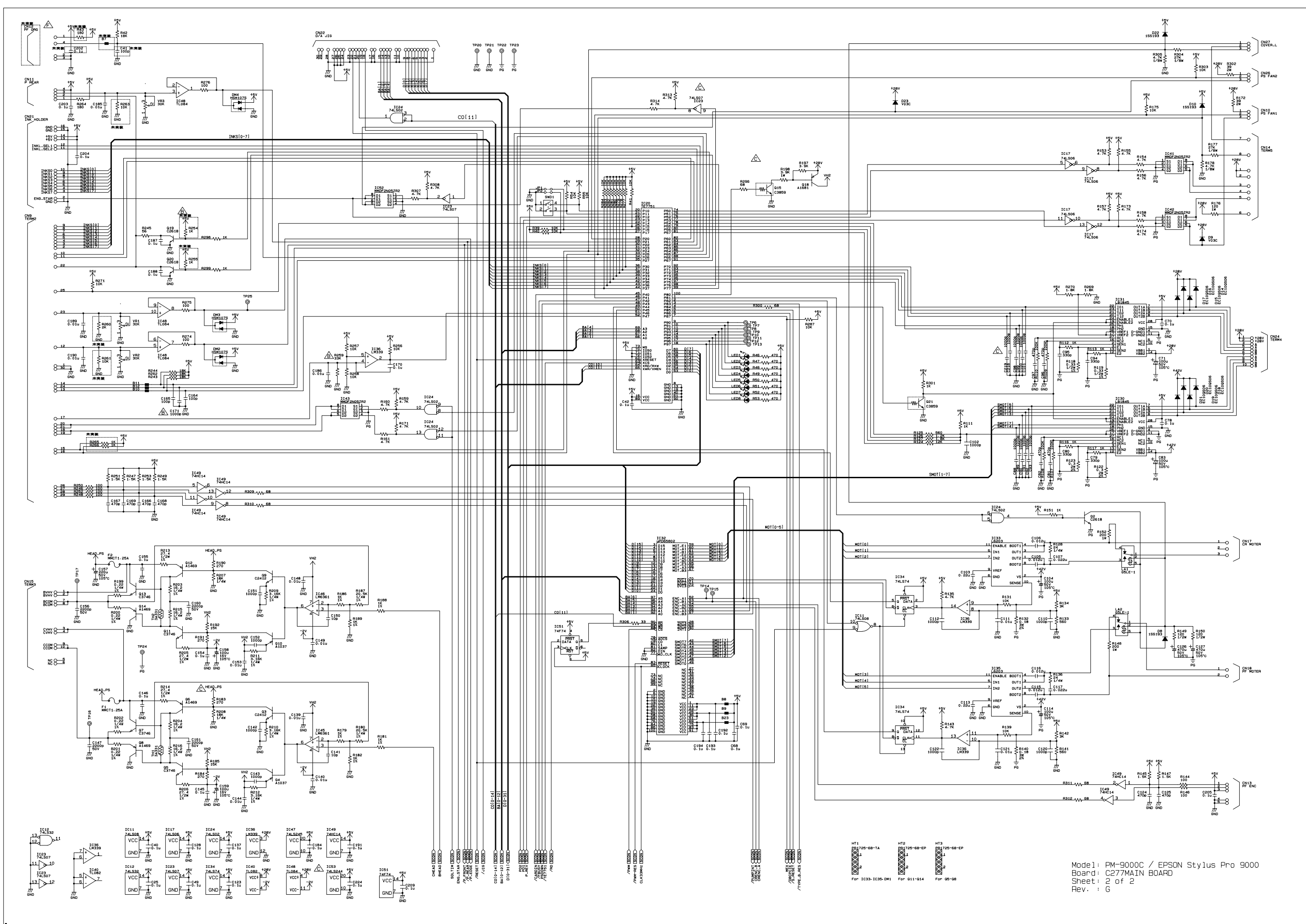

Model: PM-9000C / EPSON Stylus Pro 9000
 Board: C277MAIN BOARD
 Sheet: 2 of 2
 Rev.: 6